

TIME OPTIMIZATION USING CPM, PERT AND PDM METHODS IN THE SOCIAL AND DEPARTMENT OF KELAUTAN BUILDING DEVELOPMENT PROJECT GRESIK DISTRICT

Ardabil Maulana, Fredy Kurniawan

Narotama University, Surabaya

ardabilmaulana95@gmail.com

ABSTRACT

Planning a project there are many important things that affect the success and smoothness, one of which planning time implementation of the right and efficient work. The way to overcome the problem is by using several methods such as CPM (*Critical Path Method*), PERT (*Project Evaluation and Review Technique*), PDM (*Precedence Diagram Method*). From the calculation result show that the duration of project completion using CPM method is 57 weeks, project completion duration using PERT method is 78 + 7.5 weeks with the probability of achieving project completion time target is 99.87% and project completion duration using PDM method is 30 weeks. So the method that best suits the Social Service Development Project and the Office of Marine Gresik Regency is the PDM method because the PDM method is capable of producing shorter project completion periods than the CPM and PERT methods of 30 weeks.

Keywords: CPM (*Critical Path Method*), PERT (*Project Evaluation and Review Technique*), PDM (*Precedence Diagram Method*)

INTRODUCTION

The world of planning (design) and construction is currently growing in line with the development of human life in meeting the needs for better, more precise and efficient space. In a project the planning stage is the key to success because it determines the allocation of funds, the time and quality to be achieved. However, without good planning it is impossible to realize a product of quality development.

According to Nurhayati (2010: 4), the project is a business / activity that is complex, not routine, limited by time, budget, resources and performance specifications designed to meet consumer needs. A project can also be interpreted as an effort or activity organized to achieve important goals, objectives and expectations by using the budget of funds and available resources, which must be completed within a certain period of time.

In a project implementation there are many important things that influence the success and smoothness of it, one of which is planning the timing of the implementation of the right and efficient work. This is because that if the time of

execution of the work of a project runs longer, it will affect the costs to be incurred and the losses will have an impact on the owner and executor of the project

The ways to overcome the above problems are by several methods such as CPM (Critical Path Method), PERT (Project Evaluation and Review Technique), PDM (Precedence Diagram Method). According to Trisniati's research (2015: 79), Based on the results of the CPM (Critical Path Method) method, PERT (Program Evaluation And Review Technique), and PDM (Procedure Diagram Method), it can be compared to determine which method is more effective and close to implementation time in the field. In this study, a more effective method of making a schedule / time of implementation is the PDM Method (Procedure Diagram Method). Because besides being able to save on implementation time, this method is also more precise and efficient to use. This is because this method is suitable for construction work that has many work items, but can be overlapped.

Whereas according to Haizer and Render (2015: 63), the CPM (Critical Path Method) and PERT (Project Evaluation and Riview Technique) methods both have a basic step in determining the project and preparing work breakdown structures, developing relationships between activities, determining which activities should take precedence and which must follow other activities, describe the network that connects all activities, determine the time and cost estimation for each activity, calculate the longest time path through the network (this is called the critical path / CPM), use the network to help plan to determine schedule to supervise and control the project.

The Project for Construction of the Social Service Building and the Marine Service of Gresik Regency is one of the government-owned projects that must be completed in a timely manner. Therefore from the existence of several methods in handling the project completion time, the project can run on time.

RESEARCH METHODS

This research method uses descriptive quantitative methods. With the data collection stage, namely field observation and literature study. This research was carried out in the Construction Project of the Social Service Building and the Gresik Regency Marine Service. Data analysis techniques using CPM (Critical Path Method), PERT (Project Evaluation and Review Technique), PDM (Precedence Diagram Method) and by using MS Project 2007 program.

RESULTS AND DISCUSSION

The main objective in this study is to find out what method is most suitable for the Construction Project of the Social Service Building and the Marine Service of Gresik Regency.

1. Results of Data Analysis with CPM (Critical Path Method) Method

This critical path method aims to identify critical pathways in the development project. Delays in one component of the activity will cause delays in the implementation of the project. The description of the components of activities in this project are as follows.

Tabel 1. Component of Activities, Logic of Dependence and Duration of Work for Construction Project of the Social and Marine Office of Gresik Regency

No.	Item Pekerjaan	Durasi (Minggu)	Predecessor	Successor
1	Preparatory Work	6	-	2, 3
2	Land Work and Heaps	4	1	4
3	Lower Structure Work	5	1	4
4	Upper Structural Work	11	2, 3	5, 6, 8
5	Roof work	6	4	11, 12
6	Couples Work	10	4	7
7	Work of Doors, Windows and Partitions	9	6	11, 12
8	Lightweight and Acian Brick Rendering Work	9	4	9, 13, 17
9	Floor Covering Work	9	8	10
10	Ceiling Work	5	9	11, 12
11	Sanitair work	4	5, 7, 10	16
12	Painting Work	7	5, 7, 10	16
13	Panel Work & Lighting Installation / Armature	6	8	14
14	Fedeer & Cubical Cabling Procurement Work	8	13	15
15	Lightning dealer jobs	2	14	16
16	Connection of new power to 197 KVA PLN	5	11, 12, 15, 19	-
17	Dirty Water Piping Work, Rainwater, Clean Water & Hot Water	13	8	18
18	Fire Detector / Alarm System Work	2	17	19
19	Air Conditioning System Work	6	18	16

Below is a network of work on the Construction Project of the Social Service Building and the Marine Service of Gresik Regency.

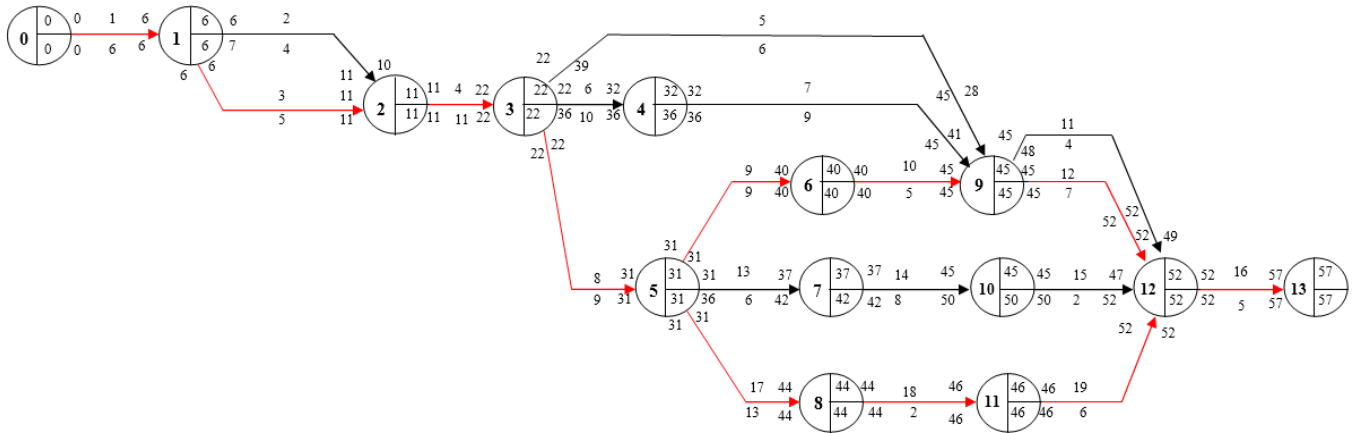

Figure 1. Critical Pathway in the Work Network of the Construction Project of the Social and Marine Office of Gresik Regency

Based on the identification of the image above, which includes the critical path, the lines that are colored red are 1, 3, 4, 8, 9, 10, 12, 17, 18, 19, 16 with the following descriptions:

- a. Preparatory work
- b. Lower Structure Work
- c. Upper Structural Work
- d. Lightweight and Acian Brick Rendering Work
- e. Floor Covering Work
- f. Ceiling Work
- g. Painting Work
- h. Connection of new PLN 197 KVA Power
- i. Work on Piping Dirty Water, Rainwater, Clean Water & Hot Water
- j. Fire Detector / Alarm System Work
- k. Air Conditioning System Work

2. Results of Data Analysis with the PERT Method (Project Evaluation and Review Teqnique)

In the calculation using the PERT method aims to deal with situations with high levels of uncertainty in the aspects of the period of activity. Where PERT uses three estimation numbers, namely a, b and m. Below is described the calculation of data analysis with the PERT method as follows.

Table 2. Estimates of Figures a, b, m, t, standard deviation (S) and variance (V (te)) Project for Construction of the Social and Marine Service Office of Kabupaten Gresik

No.	Item Pekerjaan	a	m	b	te	S	V(te)
1	2	3	4	5	$6 = (1/6)(a+4m+b)$	$7 = (1/6)(b-a)$	$8 = 7^2$
1	Preparatory Work	4	10	7	8.5000	0.5000	0.2500
2	Land Work and Heaps	2	8	6	6.6667	0.6667	0.4444
3	Lower Structure Work	4	10	7	8.5000	0.5000	0.2500
4	Upper Structural Work	7	18	14	15.5000	1.1667	1.3611

No.	Item Pekerjaan	a	m	b	te	S	V(te)
5	Roof work	3	12	7	9.6667	0.6667	0.4444
6	Couples Work	7	15	12	13.1667	0.8333	0.6944
7	Work of Doors, Windows and Partitions	5	12	9	10.3333	0.6667	0.4444
8	Lightweight and Acian Brick Rendering Work	5	12	9	10.3333	0.6667	0.4444
9	Floor Covering Work	5	12	9	10.3333	0.6667	0.4444
10	Ceiling Work	3	12	7	9.6667	0.6667	0.4444
11	Sanitair work	2	8	6	6.6667	0.6667	0.4444
12	Painting Work	5	12	10	10.5000	0.8333	0.6944
13	Panel Work & Lighting Installation / Armature	4	10	7	8.5000	0.5000	0.2500
14	Fedeer & Cubical Cabling Procurement Work	5	12	10	10.5000	0.8333	0.6944
15	Lightning dealer jobs	1	4	3	3.3333	0.3333	0.1111
16	Connection of new power to 197 KVA PLN	3	12	7	9.6667	0.6667	0.4444
17	Dirty Water Piping Work, Rainwater, Clean Water & Hot Water	7	17	14	14.8333	1.1667	1.3611
18	Fire Detector / Alarm System Work	1	4	3	3.3333	0.3333	0.1111
19	Air Conditioning System Work	3	12	7	9.6667	0.6667	0.4444

Based on the above calculation, the project completion time span is 78 + 7.5 with the possibility of achieving the project completion time target of 99.87%.

2. Result of Data Analysis with PDM Methode (Precedence Diagram Method)

This calculation using the PDM method uses a network that is included in the AON (activity on node) classification which will be described as follows.

Table 3. Activity, Duration and Construction of the Construction Project for the Social and Marine Service Office of Gresik Regency

No.	Item Pekerjaan	Durasi (Minggu)	Konstrain
1	Preparatory Work	6	-
2	Land Work and Heaps	4	FS(1-2)=0
3	Lower Structure Work	5	FS(1-3)=0
4	Upper Structural Work	11	SS(2-4)=1; SS(3-4)=2
5	Roof work	6	SS(4-5)=9
6	Couples Work	10	SS(4-6)=2

No.	Item Pekerjaan	Durasi (Minggu)	Konstrain
7	Work of Doors, Windows and Partitions	9	SS(6-7)=4
8	Lightweight and Acian Brick Rendering Work	9	SS(4-8)=2
9	Floor Covering Work	9	SS(8-9)=3
10	Ceiling Work	5	SS(9-10)=6
11	Sanitair work	4	FS(5-11)=0; FS(7-11)=0; SS(10-11)=4
12	Painting Work	7	SS(10-12)=4
13	Panel Work & Lighting Installation / Armature	6	SS(8-13)=3
14	Fedeer & Cubical Cabling Procurement Work	8	SS(13-14)=5
15	Lightning dealer jobs	2	SS(14-15)=6
16	Connection of new power to 197 KVA PLN	5	SS(11-16)=2; SS(12-16)=2; SS(15-16)=1; SS(16-19)=1
17	Dirty Water Piping Work, Rainwater, Clean Water & Hot Water	13	SS(8-17)=3
18	Fire Detector / Alarm System Work	2	SS(17-18)=10
19	Air Conditioning System Work	6	SS(18-19)=1

Based on the table above, it will be spelled out in the form of a node plan with the number of activities listed in the table and connecting these nodes with arrows according to the logic of dependence and the constraints of each as shown below.

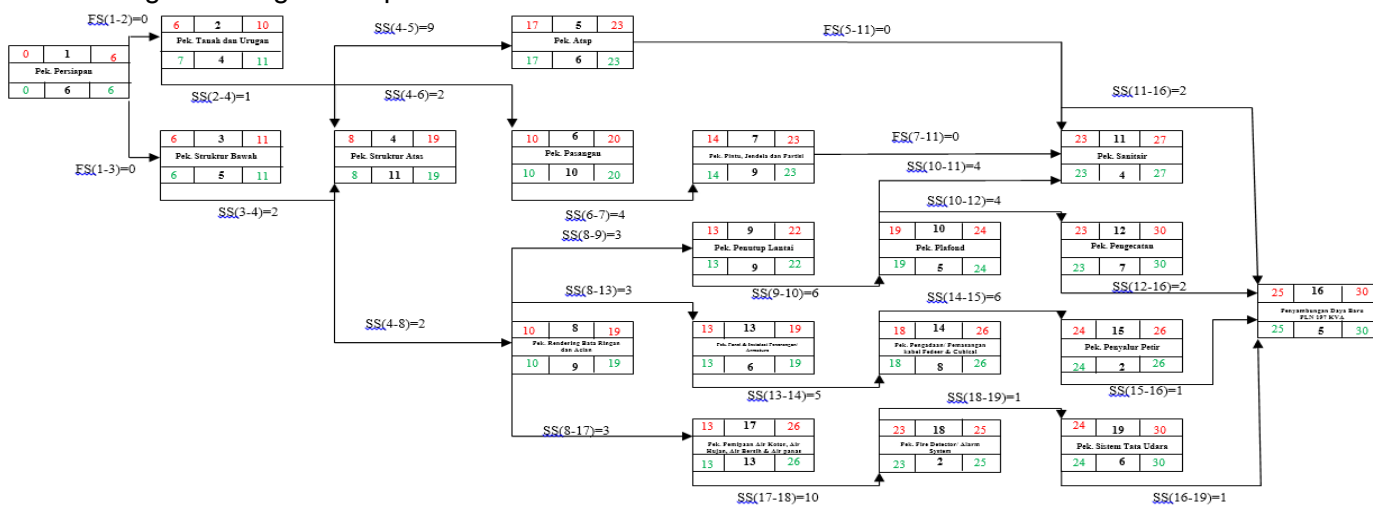

Figure 2. Node, Duration, Constructions, ES, EF, LS and LF Project for Construction of Gresik Regency Social and Marine Office Building

Based on the calculation above, it can be seen that the activity that has float is 2, while activities that do not have float which means that these activities are critical are 1, 3, 4, 5, 6, 7, 8, 9, 10, 11, 12, 13, 14, 15, 16, 17, 18 and 19. The network using the PDM method can be seen in the following figure.

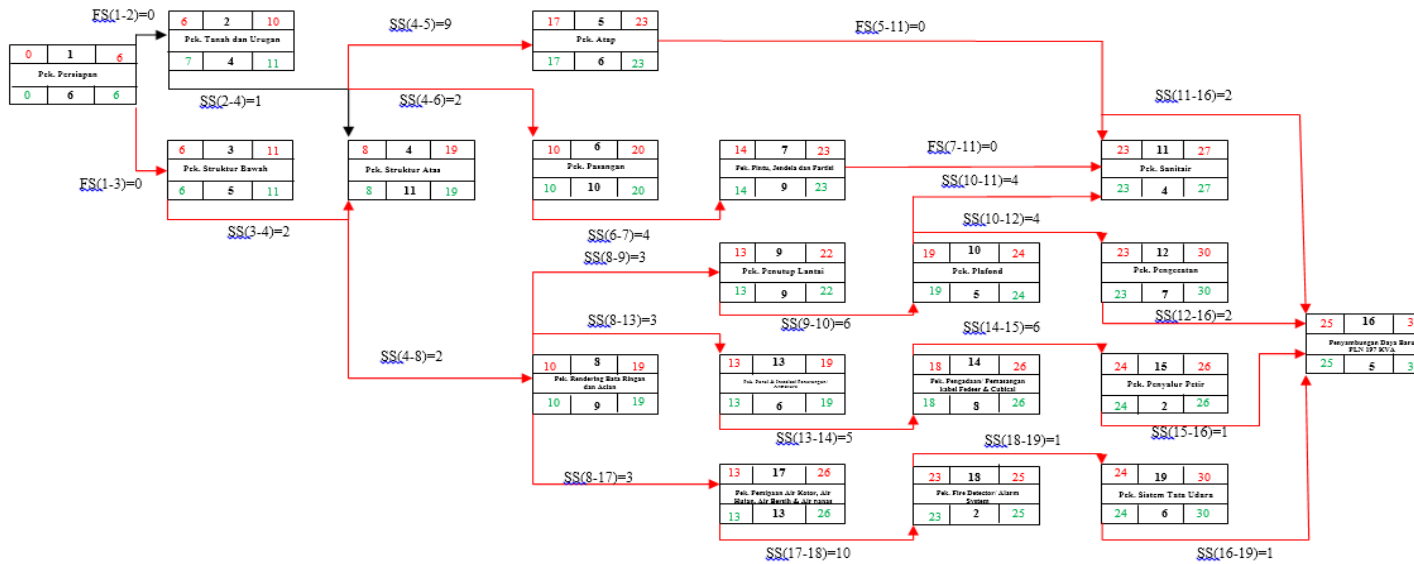
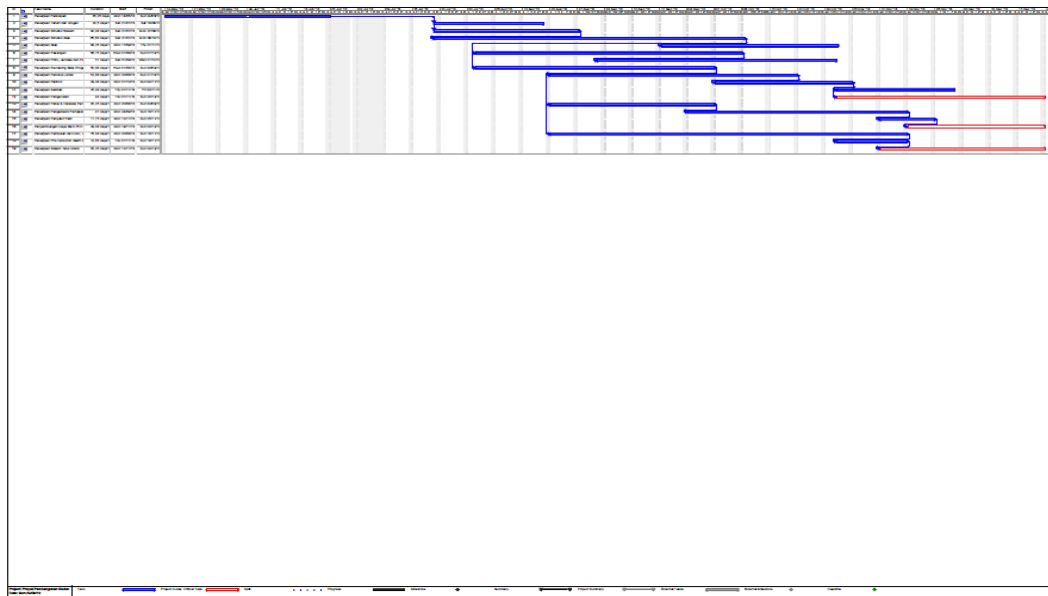

Figure 3. PDM Working Network in the Construction Project of the Social and Maritime Office of Gresik Regency

4. Results of Data Analysis with the Microsoft Project Program



while in the PDM method, the activity can be started without having to wait for the predecessor to finish; (e) In the CPM and PERT method, activities are carried out sequentially while in the PDM method the project activities can be carried out simultaneously without having to be done sequentially; (3) The duration of project completion using the CPM method is 57 weeks, the duration of project completion using PERT method is 78 + 7.5 weeks with the possibility of achieving the project completion time target of 99.87% and the duration of project completion using the PDM method is 30 weeks; (4) The method that is most suitable for the Development Project of the Social Service Office and the Gresik Marine Service is the PDM method because the PDM method is able to produce a shorter period of project completion time than the CPM method and PERT which is 30 weeks.

REFERENCES

- [1] Aditya, Dana. 2013. Analisis jaringan CPM-PERT untuk optimalisasi pembangunan wahana permainan bengkel suroboyo carnival (Skripsi yang tidak dipublikasikan), Universitas Wijaya Kusuma, Surabaya.
- [2] Basriati, Sri dan Afri Melda. 2017. Analisis Biaya Pembangunan Proyek Perumahan Menggunakan Metode PERT dan EVM (Studi Kasus: Perumahan D'Lion Cluster) (Skripsi yang tidak dipublikasikan), UIN Sultan Syarif Kasim Riau, Pekanbaru.
- [3] Caesaron, Dino dan Andrey Thio. 2015. Analisa penjadwalan waktu dengan metode jalur kritis dan PERT pada proyek pembangunan ruko (jl. pasar lama no.20, glodok). *Journal of Industrial Engineering & Management Systems*, 8(2).
- [4] Danyanti, Eka. 2010. Optimalisasi pelaksanaan proyek dengan metode PERT dan CPM (Studi Kasus Twin Tower Building Pasca Sarjana Undip) (Skripsi yang tidak dipublikasikan), Universitas Diponegoro, Semarang.
- [5] Hayun, Anggara. 2005. Perencanaan dan pengendalian proyek dengan metode PERT – CPM: studi kasus fly over ahmad yani, karawang (Skripsi yang tidak dipublikasikan), UBINUS.
- [6] Heizer, Jay and Barry Render. 2015. *Manajemen Operasi: Keberlangsungan dan Rantai Pasokan*. Edisi Sebelas. Jakarta: Salemba Empat.
- [7] Irawati, Reno Desi. 2017. Analisis Pelaksanaan Proyek Dengan Metode PERT (Studi Kasus Proyek Pembangunan Rumah Tipe 165 The Nusa Penida House Kota Blitar) (Skripsi yang tidak dipublikasikan), Universitas Nusantara PGRI, Kediri.
- [8] Juandy, Yenita. 2007. Penerapan Metode PERT dan CPM pada Suatu Jaringan Kerja (Network) serta Mengoptimalkan Waktu Penyelesaian Proyek (Skripsi yang tidak dipublikasikan), Sekolah Tinggi Manajemen Informatika dan Komputer LIKMI.
- [9] Kusananto. 2010. Penjadwalan proyek konstruksi dengan metode PERT (studi kasus proyek pembangunan gedung r.kuliah dan perpustakaan pgsd kleco fkip uns tahap I) (Skripsi yang tidak dipublikasikan), Universitas Sebelas Maret, Surakarta.

- [10] Mas'ud, M.Imron, dan Erik Wijayanti. 2017. Analisis evaluasi biaya dan penjadwalan waktu proyek pengolahan limbah PT. KI dengan pendekatan PERT (Skripsi yang tidak dipublikasikan), Universitas Yudharta, Pasuruan.
- [11] Mayasari, Agatha. 2015. Penerapan metode PERT dan CPM (Studi Pada Perusahaan Baja Sakti Construction)(Skripsi yang tidak dipublikasikan), Universitas Atma Jaya, Yogyakarta.
- [12] Nugroho, Aryo Andri. 2007. Optimalisasi penjadwalan proyek pada pembangunan gedung khusus (laboratorium) stasiun karantina ikan kelas 1 tanjung mas semarang (Skripsi yang tidak dipublikasikan), Universitas Negeri Semarang, Semarang.
- [13] Nurhayati. 2010. Manajemen Proyek. Graha Ilmu: Jogjakarta.
- [14] Ridho, Muhammad Rizki dan Syahrizal. 2015. Evaluasi penjadwalan waktu dan biaya proyek dengan metode PERT dan CPM (Studi Kasus: Proyek Pembangunan Gedung Kantor Badan Pusat Statistik Kota Medan Di Jl. Gaperta Medan, Sumatera Utara.)(Skripsi yang tidak dipublikasikan), Universitas Sumatera Utara, Medan.
- [15] Sabariah, Iqma, Syaiful dan Noor Ida Hayati. 2012. Analisis metode network planning dan s-curve proyek konstruksi di bogor (Skripsi yang tidak dipublikasikan), Universitas Ibn Khaldun, Bogor.
- [16] Sahid, Dadang Syarif Sihabudin. 2012. Implementasi critical path method dan PERT Analysis pada proyek global technology for local community. (Skripsi yang tidak dipublikasikan), Politeknik Caltex Riau, Pekanbaru.
- [17] Setiawati, Sri, Syahrizal dan Rezky Ariessa Dewi. 2015. Penerapan metode CPM dan PERT pada penjadwalan proyek konstruksi (Studi Kasus: Rehabilitasi/ Perbaikan Dan Peningkatan Infrastruktur Irigasi Daerah Lintas Kabupaten/Kota D.I Pekanbaru Dolok)(Skripsi yang tidak dipublikasikan), Universitas Sumatera Utara, Medan.
- [18] Sugiyono. 2003. Metode Penelitian Bisnis. Edisi 1, Bandung: Alfabeta.
- [19] .2010. Metode Penelitian Pendidikan Pendekatan Kuantitatif, kualitatif, dan R&D. Bandung: Alfabeta
- [20] .2012. Metode Penelitian Kuantitatif Kualitatif dan R&D. Bandung: Alfabeta.
- [21] Sujaiyis, Abdurrahman. 2017. Analisis optimalisasi waktu dan biaya pada proyek gedung smpn 1 dawar dengan menggunakan metode CPM, PERT dan TCTO Di Pt Mustika Zidane Karya (Skripsi yang tidak dipublikasikan), Sekolah Tinggi Teknik Qomaruddin, Gresik.
- [22] Sulhadi dan Didih Sumiardi. 2005. Analisa penjadwalan proyek pembuatan piano digital "xy" dengan menggunakan CPM (critical path method) dan crashing time di pt. kawai indonesia plant (Skripsi yang tidak dipublikasikan), STT Wastukencana.
- [23] Suryanto, Mas dan Hasan Dani. 2005. Manajemen Proyek II. Surabaya: Universitas Negeri Surabaya