

DOUBLE LAYER IMPEDANCE ANALYSIS ON THE ELECTRICAL IMPEDANCE MEASUREMENT OF SOLUTION USING A PARALLEL PLATE

Chomsin Sulistya Widodo¹, Didik R Santosa², Unggul P Juswono³

^{1,2,3}Department of Physics, Brawijaya University

Email: ¹chomsin@ub.ac.id

ABSTRACT

This research discusses the principles of measuring the electrical impedance of a solution using parallel plate probe. The method used is by injecting an AC-current in the solution within the frequency range of 1Hz - 1MHz. The electrical impedance value plotted as a function of frequency. The results of the experiment showed that the electrical impedance of a solution could be measured correctly by using this method. The surface area of the probe, the distance between the probe, and the frequency of the injected AC-current, giving the measured impedance value changes significantly. This method also proved to be used to identify the value of the concentration of the sugar solution with relatively good accuracy. The experiment results demonstrate conformity with the existing theory.

Keywords: *plate parallel; electrical impedance, solution impedance*

1. INTRODUCTION

The physical characteristics of a material can be studied by observing its changes after the application of electricity and magnetism (Wang et al. 2003). Impedance spectroscopy technique has also been applied to the determination of the content of artificial additives in food products. In that study have also investigated the electrical properties of the electrolyte water solution into a common food preservative, which consists of several types of ion (Nakonieczna et al. 2016).

Measurement of the electrical impedance of a solution can be done by many methods, such as direct current injection method (two probes and four probes), AC bridge method,

the optical method, and the other. However, some of these methods, the method of direct current injection is more desirable because the methods are simple and do not require expensive equipment. This approach used to apply in the fields of agriculture, food, and medicine, Medical Physics or Geophysics (Bonanos et al. 2012; Szyplowska et al. 2013; Zia et al. 2013). One model is the electrical impedance measurements using a parallel plate and current injections.

Electrical impedance measurement is based on a parallel plate is done by using current injection, which means it is giving AC current in amplitude and frequency ranges specified in the material. The complex impedance value of the material is a comparison between the voltages measured with the current injected. Due to the nature of the complex impedance, then shape and arrangement of electrodes (probe) to be very influential on the measurement results. The linkage between the electrode and the current source (probe) is critical to the value of the impedance.

In this case, it is interesting to conduct a study on the shape and arrangement of electrodes used in electric impedance measurements with models of parallel plates in a liquid medium. In the present study, two circular probe electrodes were used to measure the electrical impedance of liquid medium (solution) in the frequency range 1 Hz to 10 MHz.

2. MATERIALS AND METHODS

2.1 Design of Measurement Systems

Probe plate made of copper PCB cut a circle, each diameter of 1.5 cm and 1.0 cm as shown in Figure 1. Plates will be arranged as

parallel-plate models for each diameter. The distance between the plates will be varied, namely 3, 5, 7, 9, 11 mm. Comparison of the performance of each plate and each plate distance will be done by injecting current of 1 mA with a frequency range between 1 Hz - 10 MHz. A DAQ system consists of parallel plate system, DAQ measurement hardware, and a computer with programmable software as shown in Figure 2.

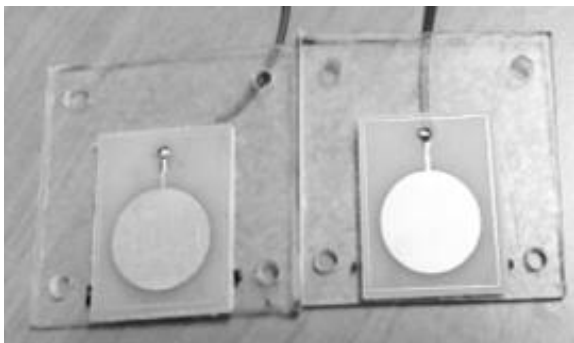

Figure 1. Probe model of copper plate

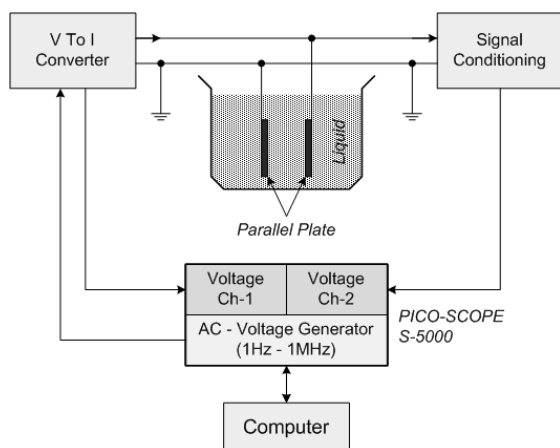

Figure 2. Design of electrical impedance measurement systems

The parallel plate sensor system was supported by current injection and coaxial cable. PICO-SCOPE S-5000 primarily functions as a device that digitizes incoming analog signals so that a computer can interpret the signal from plate parallel. The frequency ranges 1 Hz to 10 MHz was covered by the device.

2.2 Frequency Response of Module V to I

V to I converter module functions to provide a stable source of AC current. In this case, the frequency can be set. The converter system consists of electrical buffer circuit using IC LF353 and differential amplifier using AD620. LF353 and AD620 have the advantage of high input impedance and stable at frequencies up to 1 MHz and has a low price (LF353 datasheet).

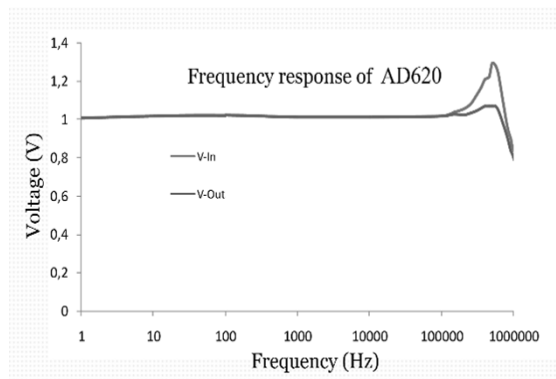

Figure 3. The frequency response AD620 in module V to I converter

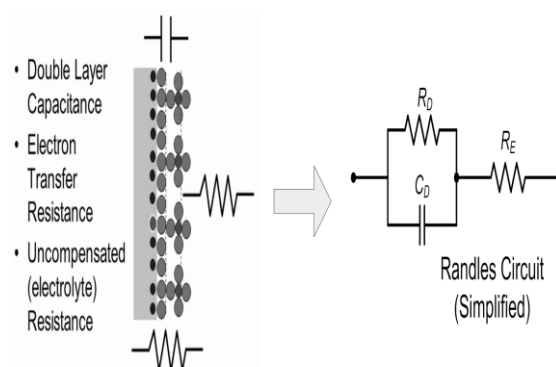

Figure 3. The Randels Model

The test results on module V to I as shown in Figure 3. The module has a perfect response in the frequency range between 1 Hz to 1 MHz, which means this module produces stable measurements in the frequency range.

2.3 Electrical Equivalent Circuit

Electrical equivalent circuit approach (EEC) is required to interpret the results of impedance spectroscopy. The specific model of an electric circuit similar approach can be used even if the research is investigated. An

electrical impedance spectrum of a constructed electrical equivalent circuit reproduces the one obtained during the study.

In this study, the electrical equivalent circuit uses Randle's Models as shown in Figure 4. This should suggest that an AC experiment can differentiate between these two resistors. High frequency signals pass right through C_D with no voltage drop while they are forced to drop current in cell $I_{cell} * R_E$ volts going through R_E just like low frequencies.

At low frequencies where C_D is effectively an open circuit, the measured impedance is the sum of R_D and R_E . At high frequencies where C_D is effectively a short circuit, the measured impedance is R_E .

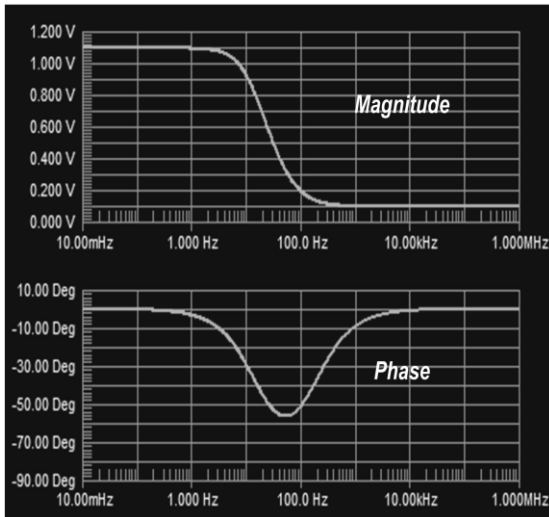

Figure 5. Computer simulations of the Randle models, where $I = 1 \text{ mA}$, $R_D = 1 \text{ k}\Omega$, $C_D = 10 \mu\text{F}$, and $R_E = 100 \Omega$,

Figure 5 shows that the results of computer simulations of the model Randle, using a program Circuit Maker 2000, on condition $R_D = 1 \text{ k}\Omega$, $C_D = 10 \mu\text{F}$, and $R_E = 100 \Omega$, and the amplitude of the injection current of 1 mA .

2.4 Materials

Electrical impedance measurement is done by placing a solution of 100 ml mineral water into a container and plate diameter of 1.1 cm. at various distances between the plates of 0.3, 0.5, 0.7, 0.9 and 10 cm. Distance plates which provide good measurement results will be used to measure the impedance of the sugar

solution. Comparison of impedance values at different concentrations of sugar made by dissolving sugar, each of mass 10, 20, 30, 40, 50 gram, into 100 ml mineral water.

3. RESULTS AND DISCUSSION

The electrical impedance of mineral water medium at a various distance of plate with diameter 1,5 cm as shown in Figure 6. Overall, the trend curve shows a logarithmic graph, which corresponds to the Randle model which total impedance value is determined components of the resistance and capacitance of the parallel plate models.

Measurements using parallel plate method is largely determined by the shape and dimensions of the plates. Distance plate 0.3 cm to 1.1 cm in the frequency range of 1 Hz to 10 kHz provides a declining trend similar impedance values as the frequency increases. This means that the measurement device that is designed to provide meaningful measurements in the frequency range of 1 Hz to 10 kHz. If the enlarged frequency up to 1 MHz, then the distance plate that can be used to measure the electrical impedance of a solution is within 1.1 cm, where the results of the study showed significant differences in the impedance value of the range.

Electrical impedance water continued rising with increasing distance between parallel plates, as shown in Figure 7. At a distance of 1.1 cm for various frequencies showed a significant difference compared to other distances.

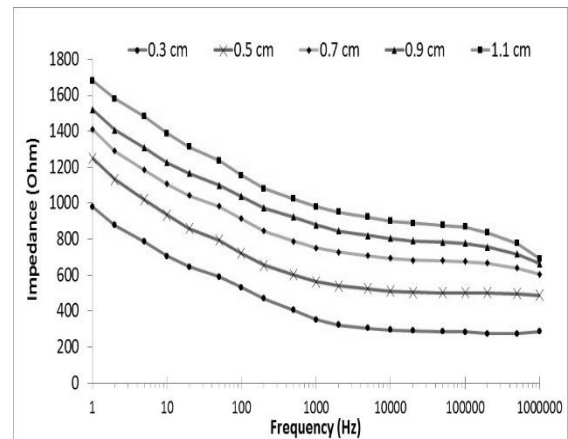

Figure 6. The electrical impedance of mineral water medium at a various distance of plate with diameter 1,5 cm.

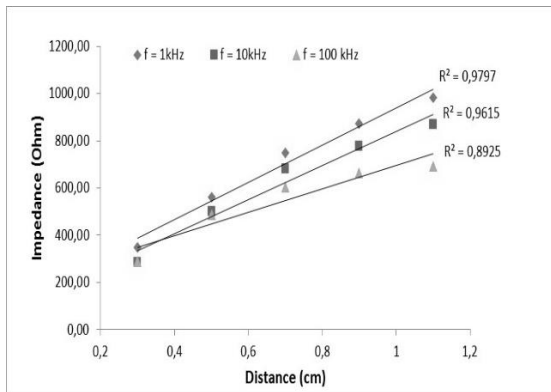

Figure 7. Electrical impedance of mineral water at various frequency with diameter of plate 1,5 cm

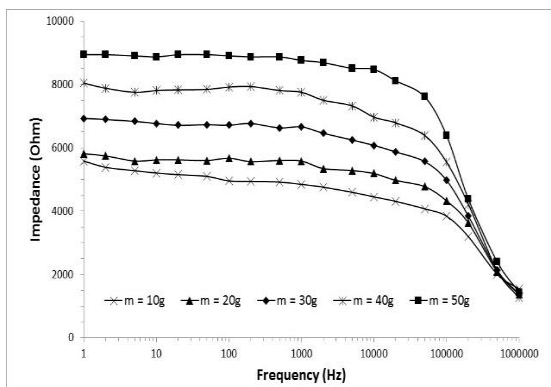

Figure 8. The electrical impedance of solution sugar medium at the various mass of sugar with distance 1,1 cm.

This means that the impedance measuring device will be well used to using a measure of distance is 1.1 cm. This distance will be used to test the impedance value of the sugar solution.

The measurement results using a sample solution of sugar, in the frequency range of 1 Hz to 10 MHz as shown in Figure 8., there are two parts that are part of the first in the frequency range of 1 Hz to 10 kHz which shows the impedance value of sugar solution decreases with slope lower due to higher frequency. Meanwhile, the second part at a frequency of 10 kHz to 100 MHz, the electrical impedance value declined sharply in line with increasing frequency.

In a solution of sugar, sugar has a resistance value larger than water. So if the greater the mass of sugar is added to the

mineral water, it will raise the value of the electrical impedance.

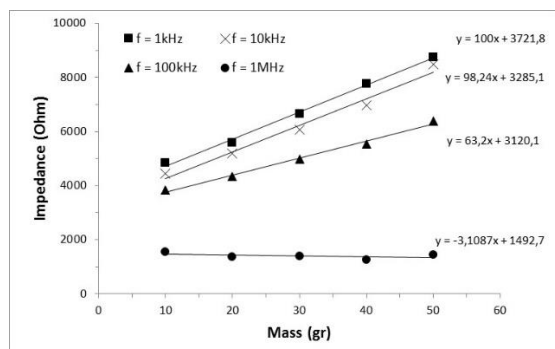

Figure 9. The electrical impedance of solution sugar medium at various frequencies with distance 1,1 cm.

In the range between 1 Hz to 10 kHz provide impedance value likely to be stable. It shows that the large impedance is the sum of the resistance of double layer and resistance of the solution ($ZT = R_D + R_E$). If R_D is considered constant and $R_E = \rho L / A$, where ρ = the resistance of sugar, by adding the mass of sugar will increase the resistance of sugar so that the impedance measured will be even greater.

The addition of sugar mass will correlate linearly with the electrical impedance value, as shown in Figure 9. This is due to the electrical conductivity properties of sugar (Juansah et al. 2016).

4. CONCLUSIONS AND SUGGESTION

The electrical impedance of a solution could be measured correctly by using this method. The surface area of the probe, the distance between the probe, and the frequency of the injected AC-current, giving the measured impedance value changes significantly. This method also proved to be used to identify the value of the concentration of the sugar solution with relatively good accuracy. The experiment results demonstrate conformity with the existing theory

5. ACKNOWLEDGEMENTS

This research was funded by Ministry of Research, Technology and Higher Education

of the Republic of Indonesia with the agreement of assignment Number: 007/Add/SP2H/PL/ DIT.LITAB MAS/V/2015, on May 17, 2015.

6. REFERENCES

- BONANOS, NIKOLAOS et al. 2012. "Impedance Spectroscopy of Dielectrics and Electronic Conductors." In *Characterization of Materials*, Hoboken, NJ, USA: John Wiley & Sons, Inc. <http://doi.wiley.com/10.1002/0471266965.com121> (August 15, 2016).
- JUANSAH, JAJANG et al. 2016. "Studies on Electrical Behavior of Glucose Using Impedance Spectroscopy." *IOP Conference Series: Earth and Environmental Science* 31(1): 12039. <http://stacks.iop.org/1755-1315/31/i=1/a=012039?key=crossref.8360a19590f232c8d141bd6e0f09facc> (September 19, 2016).
- NAKONIECZNA, ANNA et al. 2016. "Electrical Impedance Measurements for Detecting Artificial Chemical Additives in Liquid Food Products." *Food Control* 66: 116–29.
- SZYPLÓWSKA, AGNIESZKA et al. 2013. "Application of a Coaxial-Like Sensor for Impedance Spectroscopy Measurements of Selected Low-Conductivity Liquids." *Sensors* 13(10): 13301–17. <http://www.mdpi.com/1424-8220/13/10/13301/> (May 20, 2016).
- WANG, YIFEN, TIMOTHY D WIG, JUMING TANG, and LINNEA M HALLBERG. 2003. "Dielectric Properties of Foods Relevant to RF and Microwave Pasteurization and Sterilization." *Journal of Food Engineering* 57(3): 257–68.
- ZIA, ASIF I. et al. 2013. "Technique for Rapid Detection of Phthalates in Water and Beverages." *Journal of Food Engineering* 116(2): 515–23.