

# Design of Inverter with Less Harmonics using Buck-Boost Converter and SPWM Method

Lalu Riza Aliyan<sup>1</sup>  
Electrical Engineering Department  
Brawijaya University, Malang, Indonesia  
aliyan04@yahoo.com<sup>1</sup>

Rini Nur Hasanah<sup>2</sup>, M. Aziz Muslim<sup>3</sup>  
Electrical Engineering Department  
Brawijaya University, Malang, Indonesia  
rini.hasanah@ub.ac.id<sup>2</sup>, muhazim2@gmail.com<sup>3</sup>

**Abstract** – In a power distribution system it is expected that the current and voltage values to be maintained constant both in terms of magnitude and frequency. However, distortion of waveforms as a result of non-linear loads connected to system is widely found in a form of harmonics. Harmonics are sinusoidal signals whose frequencies multiples of the fundamental frequency. The severity of harmonics content is commonly stated using Total Harmonics Distortion (THD), revealing the ratio of the Root Mean Square (RMS) values of all harmonic components to its fundamental component, and is expressed in percentage (%). The harmonics could engender undesired effects in some appliances. In this paper, an effort to minimize the THD value in an inverter design is described. Less harmonics were obtained using Buck-Boost Converter and Sinusoidal Pulse Width Modulation (SPWM) Method. Analysis results showed a THD reduction of 4.58 % and 4.33 % for current and voltage respectively.

**Index Terms**— Buck-boost converter, Harmonics, Inverter, SPWM.

## I. INTRODUCTION

Efficiency in energy conversion is very important, especially in the era of fast growing need for energy. It is also required in the use of electrical energy coming from renewable sources, such as solar energy. The problem often arising is how to optimally utilize the electrical energy generated by solar cells. An important element in the conversion of solar energy into ready-to-use electrical is inverter, which takes the role of converting the generated direct current and voltage into the alternating ones. The resulted waveforms always contain harmonics, which can be seen as an appearance of additional sinusoidal waveforms of frequencies being multiplication of fundamental frequency [1].

Greatly affects the system harmonics due to the harmonics will tend to place have lower impedance value. If this is the case necessarily a device will experience a distortion wave that causes the system to become disrupted work. In an electrical device will cause harmonic distortion of voltage zero crossing occurs which results in disruption of the process control equipment during operation. For certain types of devices allowable limit harmonic value is about 5% [2].

The severity of harmonics content is commonly expressed using *Total Harmonics Distortion* (THD), revealing the ratio of the Root Mean Square (RMS) values of all harmonic components to the fundamental component, and is expressed in

percentage (%). The harmonics could engender undesired effects in some appliances. It is always desired to minimize the THD, so that systems/appliances disturbances because of harmonics can be suppressed. Vary researches have been proposed to minimize the THD. Some of them proposed the measures through phase shifting and filtering methods, and claimed to decrease the THD value up to 10%. Some others proposed the measures through modification of inverter configuration, addition of filters, and pulse-width modulation to trigger inverter switches [3].

Pulse control methods can be divided into two types, i.e. *single pulse-width modulation* and *multiple pulse-width modulation*. One type of multiple pulse-width modulation is *Sinusoidal Pulse-Width Modulation* (SPWM). In previous studies [4], it was explained that a reduction of harmonic current value from 30% to 10.2% had been obtained with *phase-shifting method*. In [5] the SPWM technique using microcontroller has been proven capable to reduce the value of low-order harmonics distortion and lower-order amplitude up to values below 10%.

Most of the researches described previously focused on the SPWM method because it is the cycle time which was changed, not the number or value of the pulses. By changing the cycle time, the inverter switching process could also be controlled so that the output signal generated by inverter would also be influenced [6]. Harmonics analysis of the single-phase inverter using optimum SPWM switching will be described in this study. The type of inverter used is an H-bridge single-phase inverter, which uses 4 switches with the purpose of getting an ease in implementing the SPWM method [7].

## II. RESEARCH METHOD

Steps to do in designing inverter with less harmonic content begin with pre-researching about harmonics, by analyzing voltage and current harmonics, synthesizing distorted waveforms, and modulation index computation. Step to do proceeds with the design of buck-boost converter, the design of H-bridge inverter circuit, SPWM control circuit, and MOSFET driver circuit. The next step is testing, beginning test each block and overall system.

To facilitate the design, a block diagram of the system is made (Fig. ). It represents each supporting component, which includes a DC source, the DC-DC converter, the H-Bridge

inverter circuit, the SPWM controller circuit, and the MOSFET driver circuit. DC source in this design is functioning as the system input. The output of the DC-DC converter is then converted into AC voltage by the inverter. The DC-DC converter serves to raise or to lower the output voltage of the DC source. Inverter as the main circuit in this design comprises four MOSFETs. Controller is used as a data processing center. The input signals, i.e. the reference signal and the carrier signal, are compared and processed using the Sinusoidal Pulse-Width Modulation method.

**A. Designing Buck-Boost Converter**

Buck-Boost converter is a dc-dc converter which is capable to raise or to lower dc voltage by adjusting the duty-cycle of the switch. The circuit of inverting buck-boost converter can be functioning in three operating modes, i.e. buck mode, boost mode, and buck-boost mode [8]. There are at least two benefits obtained using this circuit. Firstly, it is useful to stabilize the voltage at a certain value. Secondly, using high switching frequency it is able to reduce the arising harmonics.

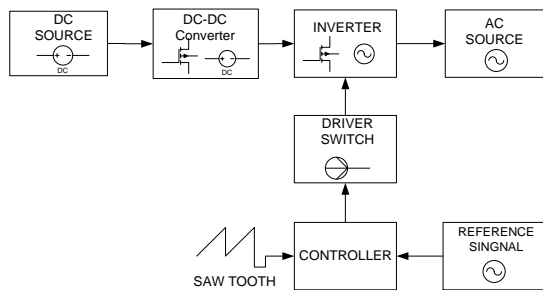

Figure 1. System block diagram

When the value of the input voltage is less than the desired voltage (set-point) then the circuit will turn into boost mode. Conversely, when the value of the input voltage is greater than the set-point voltage, the mode will change into the buck mode. When the input voltage is stable and close to the set-point voltage value, the regulator will work on a buck-boost mode.

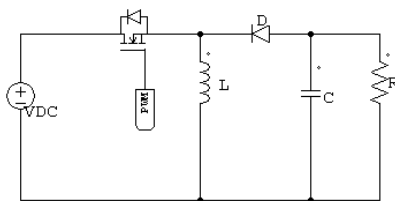

Figure 2. Buck-boost converter circuit

In this design, several parameter values have been specified previously. The input voltage of 12 volts is used, referring to the DC source output which is widely used, especially in solar cell with output voltage of 12 V. The output voltage of 24 volts is purposed to maintain the DC source output so that its value will not decrease. High-frequency value is used to accelerate the capacitor charging in the circuit.

The design parameter values of the buck-boost converter are as follows:

- input voltage = 12 V,
- output current = 3 A,
- output voltage = 24 V,

- switching frequency = 3 kHz.
- Steps in designing the buck-boost converter include:
- Determining the duty-cycle D of the PWM for input voltage of 12 volts and output voltage of 24 volts, so that the circuit is in the boost mode.
  - Determining the inductance value
  - Calculating the capacitor value using the following equations:

**B. Designing Inverter Circuit**

The main circuit in the system is an H-bridge type of the single-phase full-bridge inverter. The choice of this type has been based on its simplicity of control. Only two triggering signals working complementarily are required. The circuit consists of four MOSFETs connected to the DC voltage source. Each control device is equipped with a diode connected in parallel to each other, but in opposite direction. In [8] it was explained that the use of higher frequency value would result in lower harmonics. The smaller switching losses would also be resulted. It is the reason why a type H-Bridge inverter circuit is used as the main circuit in the system. The design results are shown in Fig. 3.

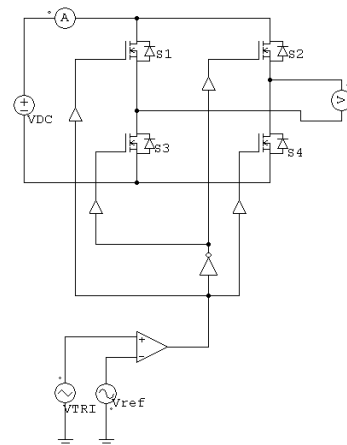

Figure 3. The inverter circuit design

The inverter output of sinusoidal form is expressed using the following formula:

$$V_{ac}(t) = V_{dc}(t) V_{spwm}(t) \tag{1}$$

with:

- $V_{ac}$  = output voltage
- $V_{dc}$  = input voltage
- $V_{spwm}$  = SPWM signal for triggering inverter

Producing a single-phase output at the load-side of a conventional inverter can be done by controlling the order of the switching. Power switches (MOSFETs) can be put into working by providing controlling pulses to the switches.

The switching pulses can be produced by sampling-based PWM technique. As can be seen from Fig. 4, when the instantaneous value of the reference voltage of the switch S1 is greater than the carrier wave, the switch S1 closes (ON). On the contrary, the switch S3 will be open (OFF). The witch S1 and the switch S3 which are located on the same inverter arm work complementarily [8].

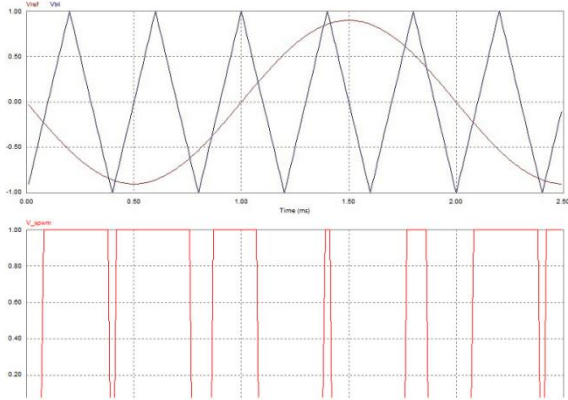

Figure 4. The designed inverter input and output signals

The magnitude of the modulation index in this design is set to value 0.9. It is the value of the ratio between the amplitude of the reference signal and the carrier signal. The modulation index values range is from 0 to 1. At this value of modulation index, the pulse width for triggering the inverter reaches its optimum point so that the possibility of distortion produced will be smaller. By determining the value of  $A_r$  and  $A_c$ , the modulation index value can be calculated using Eq. (2).

$$m_a = A_r / A_c = 1.8 / 2 = 0,9 \quad (2)$$

where  $m_a$  is the amplitude of modulation index,  $A_r$  is the amplitude of the reference signal, and  $A_c$  is the amplitude of the carrier signal [2]. In the SPWM technique, low frequency reference signal and high frequency carrier signal are needed to produce the required value SPWM.

In this design, the specified number of pulses per cycle is equal to the frequency of the carrier signal, so the number of pulses in each cycle can be calculated by Eq. (3).

$$N_p = m_f = f_c / f_o = 2500 / 50 = 50 \quad (3)$$

with  $N_p$  = number of pulses  
 $f_c$  = carrier signal frequency  
 $f_o$  = modulation signal frequency

The number  $N_p = m_f = f_c / f_o$  is defined as the ratio of the carrier signal frequency to the output voltage frequency.

If  $\delta$  is the width of each pulse, the effective output voltage in the circuit can be obtained using Eq. (4).

$$V_0 = V_s \quad (4)$$

where  $V_0$  = output voltage  
 $V_s$  = source voltage  
 $p$  = number of pulses

Modulation index is varied from 0 to 1, resulting in variation of pulse width from 0 to  $T/2p$ , and the output voltage  $V_0$  from zero to  $V_s$ .

### C. Software Design

As shown in Fig. 5, in general a software design algorithm starts with initialization of ports connected to microcontroller input. The microcontroller input signal is derived from the SPWM output signal simulated using Psim software. Text files resulted from Psim simulation is then converted into binary code using Microsoft Excel. Binary code data is then inputted

into the microcontroller program in Proteus ISIS software. By using Proteus ISIS software then simulation is run to generate an inverter output signal which can be displayed on and recorded by the virtual oscilloscope provided by the ISIS Proteus software.

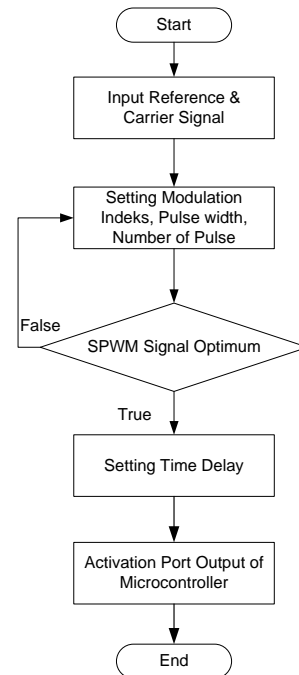

Figure 5. Software design algorithm

### III. TESTING RESULT AND DISCUSSION

The inverter circuit testing has been performed on the system as a whole, combining the entire blocks of the system (Fig. 6). Power Simulator software has been used for this purpose. The advantage of the use of this software is that it can perform the calculation and analysis of power electronics circuits and display the output in graphical forms as functions of time and frequency. In addition to simulating, Power Simulator program can also provide data to be used to implement the algorithm of the SPWM method on the controller. These data are in the form of text file which are then processed and acquired using Microsoft Excel to provide binary data.

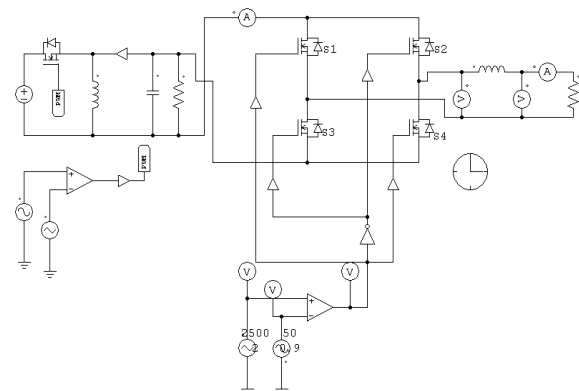

Figure 6. Overall schematic circuit testing system

Figure 6 shows that the inverter circuit uses two signals, i.e. the reference signal in a form of sinusoidal signal and the carrier signal in a form triangular signal. The reference signal has been set to 50Hz,  $9-V_p$ , while the carrier signal to 2500 Hz,  $2-V_{pp}$ . Both signals are compared to generate the modulation index of 0.9 and the number of pulses of 50 pulses/s. The SPWM signal used for triggering the inverter is shown in Figure 8.

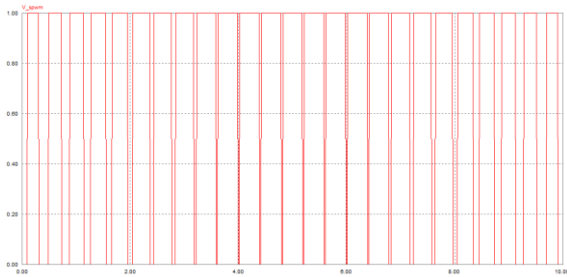

Figure 7. SPWM signal with Modulation Index of 0.9.

This SPWM signal is used as triggering signal to the driver output of the MOSFETs (S1, S2, S3, S4) on the inverter. The output signal of the controller will go to the MOSFET driver before it conducts. It is intended to avoid the controller damage if there is a surge current on the MOSFET. Fig. 8 shows the SPWM inverter output voltage signal, whereas its frequency spectral decomposition is shown in Fig. 9, started with the highest value of fundamental signal amplitude spectrum, followed with the lower values of the third up to the n-th harmonics. Fig. 10 shows the SPWM inverter output current signal, whereas its frequency spectral decomposition is shown in Fig. 11, started with the highest value of fundamental signal amplitude spectrum, followed with the lower values of the third up to the n-th harmonics.

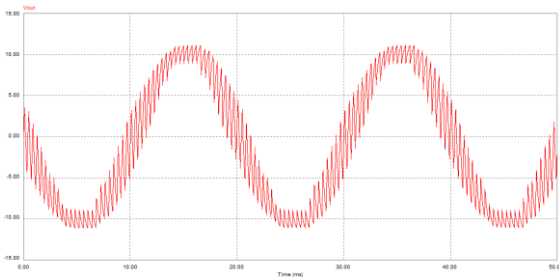

Figure 8. Output voltage signal on the load

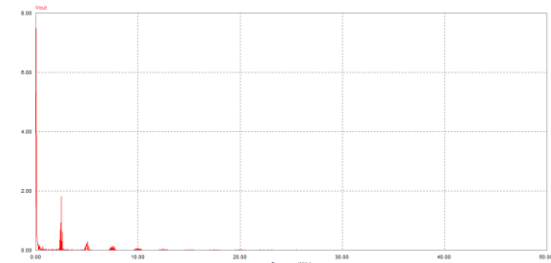

Figure 9. Output voltage frequency spectrum signal

Fundamental signal was at frequency of 1 kHz with an amplitude value of 1 A, then followed by the current harmonic

signal in the frequency range of 2.5 to 25 kHz with amplitudes decreasing its value from 0.057 amps at the third harmonic to a value close to zero at the n-th harmonic.

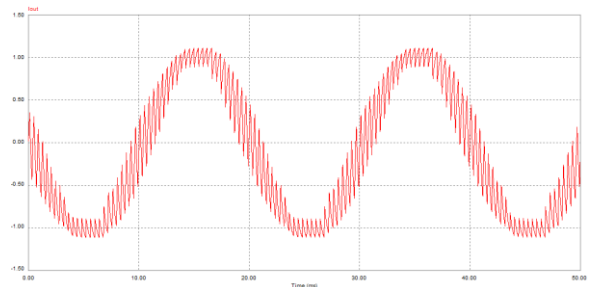

Figure 10. Output current signal on the load

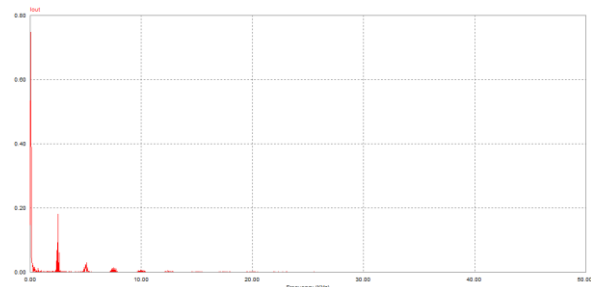

Figure 11. Output current frequency spectrum signal on the load

After having performed simulations using PSIM software, the next stage was simulated using Proteus ISIS software. Schematic circuit for simulation using Proteus ISIS software can be seen in Fig. 12.

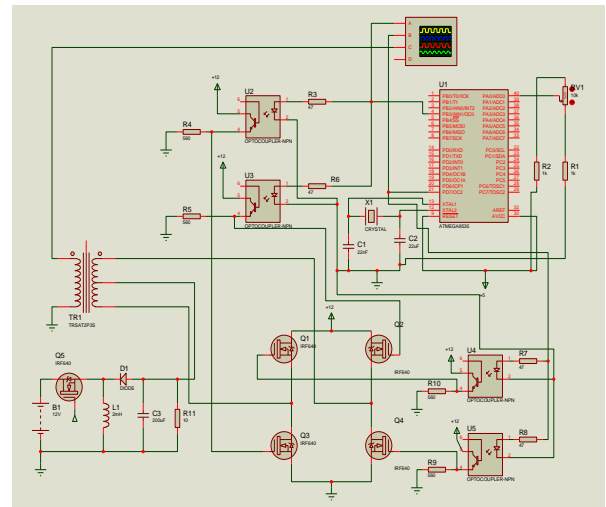

Figure 12. Overall schematic system for simulation using Proteus Software

The data obtained from PSim simulation software has been converted into binary code in Microsoft Excel and then processed using the C language in Compiler Code Vision AVR. Afterwards, the hexadata resulted in compiler has been incorporated into the simulated microcontroller in Proteus ISIS software. In ISIS Proteus software, the microcontroller circuit is connected to the inverter circuit. Finally, the generated SPWM output signal is as shown in Fig. 13.

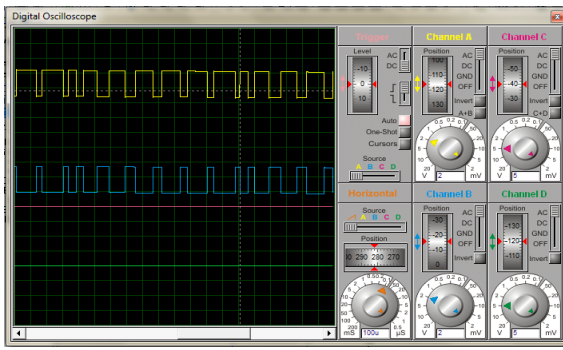

Figure 13. Inverter SPWM trigger signals generated from the Proteus ISIS software simulation

The output signal of microcontroller resulted with Proteus software has the same pattern of SPWM switching as that using PSim software. The SPWM signal will then pass through the MOSFET driver before it can conduct on the inverter circuit. This MOSFET switching conduction process will then generate an alternating current and voltage signal as the inverter circuit output. Fig. 14 shows the resulted output voltage of the inverter, measured at a frequency of 50 Hz, with each channel has been set in the range of 2V whereas the time/div has been set in the time range of 50 us. Chanel A shows the SPWM signal to trigger the MOSFETs driver of S2 and S3. Chanel B shows the SPWM signal to trigger the MOSFETs driver of S1 and S4. Channel C displays the output voltage signal of the inverter.

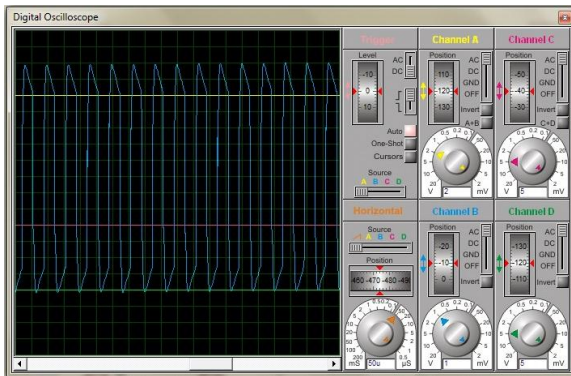

Figure 14. SPWM Inverter output voltage signal simulation results using Proteus ISIS Software

In Fig. 14, it can be seen that the generated output voltage signal is an AC voltage signal resulted from MOSFETs triggering, whose triggering signals are shown in Fig. 14. The signals are composed of the fundamental sinusoidal signal and other harmonic sinusoidal signals with frequencies being the multiples of its fundamental values. The harmonic components of inverter output voltage and current are shown in Table I.

From Table I it can be seen that the amplitude of the harmonics become smaller and smaller starting at the third harmonic and continuing to infinite harmonics.

Table I. Output Current and Voltage Harmonics

Signal Type	Vout (V)	Iout (A)
Fundamental	11.53	1.12
Harmonic 3rd	0.461	0.047
Harmonic 5th	0.192	0.019
Harmonic 7th	0.014	0.008
Harmonic 9th	0.010	0.002

In this paper, it is only limited up to the ninth harmonic. To calculate the level of harmonics content, the THD value is used [2] for both voltage and current harmonics, as follows.

$$V_{THD} = \frac{\sum_{h=3,5,7,\dots} \sqrt{V_h^2}}{V_1} = \frac{\sqrt{0,461^2 + 0,192^2 + \dots}}{1,12} = 4,33 \%$$

$$I_{THD} = \frac{\sum_{h=3,5,7,\dots} \sqrt{I_h^2}}{I_1} = \frac{\sqrt{0,047^2 + 0,019^2 + \dots}}{11,53} = 4.58 \%$$

#### IV. CONCLUSION

Based on the testing results analysis, it can be concluded that the addition of buck-boost converter is effective to reduce harmonic distortion effect so that the output voltage can be maintained at certain level of value. The use of SPWM method facilitates the switching-process of MOSFET as using this method the pulse width can be adjusted effectively to reduce the harmonics. By using the modulation index of 0,9, the THD value has reduced from 26.37% without SPWM to 25.74% with the application of SPWM method on inverter circuit. The resulted THD values of current and voltage respectively are 4.58% and 4.33%.

#### REFERENCES

- [1] Cividino, L. "Power Factor Harmonic Distortion Causes Effect and Consideration." Canada: Northern Telecom. 2000.
- [2] Bijoyprakash, M. "Analysis of Single Phase SPWM Inverter." India : National Institute of Technology, Rourkela. 2001.
- [3] Saragih, B. "Perbaikan Unjuk Kerja Inverter Satu Fasa Menggunakan Kontrol Sinyal Lebar Pulsa". Medan: USU. 2008.
- [4] Suriadi. "Analysis of Harmonics Current Minimization on Power Distribution System Using Voltage Phase Shifting". Malaysia: Universiti Sains Malaysia. 2006.
- [5] Fahma, C. Design of Three Phase Half Wave Rectifier With Minimum THD Using PI Fuzzy Switching. Surabaya: PENS-ITS. 2009.
- [6] Sugiyono, A. "Teknik Penghilangan Harmonisa Pada Inverter Satu Fasa dengan Mikroprosesor Sebagai Pembangkit Sinyal". Bandung : ITB.1988.
- [7] Suroso. "H-Bridge based Five-Level Current-Source Inverter for Grid Connected Photovoltaic Power Conditioner". Telkomnika, Vol 11, No.3, pp 489 -494. 2013.
- [8] Hidayat, S. "Rancang Bangun Buck-Boost Converter". Jakarta. Universitas Indonesia. 2010.