

## Implementation of Angklung Beat Density With Arduino and Piezoelectric Sensor Using Kalman Filter Applied for Reduce Noise Sensor

Imron<sup>1</sup>, Bagus Satria<sup>2</sup>, Mika Debora Br Barus<sup>3</sup>

Email: [imron@politansamarinda.ac.id](mailto:imron@politansamarinda.ac.id)

Teknologi Rekayasa Perangkat Lunak, Politeknik Pertanian Negeri Samarinda

### ABSTRACT

Angklung is a musical instrument consisting of several bamboo pipes arranged vertically and tied with string or rattan, so that when it is hit or shaken it produces a different sound depending on the size and thickness of the bamboo pipe. The vibrations given will cause the resulting sound resonance. The position of the handrails and how to shake are good learning parameters for beginners in operating the angklung. Knowing the number of vibrations or beats on the angklung can provide harmonization and resonance to be played together. These conditions require measurement and observation methods with the beat density of the angklung to form synchronization and harmonization. Piezoelectric sensors and Arduino are used to read the resulting vibrations. Under the conditions of the resulting vibration will cause noise. In the process of removing noise or interference, it is carried out using the Kalman Filter algorithm. The Kalman Filter algorithm is one that is widely used for noise filtering and for estimating the state of the system. The average obtained for knocks without using Kalman Filter is 9.3 beats and for those using Kalman Filter is 7.8 for a target of 5 beats. While the results of the 20-beat target condition produce an average for sensors without Kalman Filter producing an average number of beats of 25.3 and those using Kalman Filter produce an average value of 23.3 beats.

**Keywords :** Angklung, Beat, Noise, Kalman Filter, Arduino, Piezoelectric.

### INTRODUCTION

Efforts to preserve art are things that continue to be pursued in the development of the modern technological era. Especially in the art instrument that has broken many world records, namely the angklung. There are many ways that can be done in the preservation process, both in the form of digitizing the angklung game using Android and desktop applications, perform angklung game by doing robotic assembly, playing angklung in VR (*Virtual Reality*), etc. Angklung is made of bamboo which is played individually which technically is considered the easiest by vibrating or shaking the parts of the angklung. This method will emit a sound that will form a sound or tone when played together with the type of angklung which has a different sound or tone for each individual angklung player. The scheme of changes or modifications made to the angklung is the result of the intelligence and creative touch of the artist or angklung practitioner.

Modification efforts as a development step and in the framework of improvement both in physical form, technical use, and the side of the show or game packaging carried out by practitioners. The wealth of bamboo musical art that uses the word angklung as its name is spread in the Sundanese cultural area, among them angklung Baduy, angklung Dogdog Lojor, angklung Buncis, angklung Gubrag, angklung Badeng, angklung Bungko, etc. In addition, there are still many traditional performing arts that use the angklung musical instrument but do not use it as the name of the type of art that is dominantly functioning as a complement to ritual ceremonies. (Satya & Budi, 2014). In the process of sound coming out of the angklung musical instrument, the sound or tone that comes out of an angklung is produced due to a collision or collision between the large or small tube and the base tube and has a working system that is

almost the same as the sound on a closed organ pipe.

In a closed organ pipe, the high frequency is inversely proportional to the length of the pipe. The longer the closed organ pipe when pressure is applied, the lower the sound frequency will be, and vice versa the shorter the organ pipe when pressure is applied, the higher the frequency produced. Physically the concept of angklung is similar to the concept of a closed organ pipe, if the short resonant tube is shaken, the resulting sound frequency is high and if the long resonant tube is shaken, the sound frequency produced is low. Due to the collaborative nature of playing angklung music, this game encourages cooperation and mutual respect among the players, discipline, responsibility, and concentration. The sound tube consists of two tubes, namely a small tube and a large tube, where the small tube is located on the left side while the large tube is located on the right side. On the tube, there is a resonator placed on a large tube which can determine the high quality of the basic tone of the angklung. The resonator part of the angklung is a type of closed organ pipe because one end is closed.

The air in the tube is not free to move so that a knot always occurs at the end of the tube. The second part, namely the base tube, is located on the underside and also forms the basis of the sound tube frame. The third part is the framework consisting of bamboo slats that string together the sound tube and base tube so that it can function as a handle when playing the angklung. The fourth part, namely the angklung leaf, is part of the sound tube which is partly sharpened to adjust the pitch of the desired tone. In this study, we will focus on finding the beat density to create harmonized angklung playing using a piezoelectric sensor and optimizing noise with the implementation of the Kalman filter. This paper is divided into five sections are: section I explain the purpose and background of the research, section II explain the formula of the problem, the details of the problem, and design system, section III Analysis of the results of system design, section IV conclusions from research.

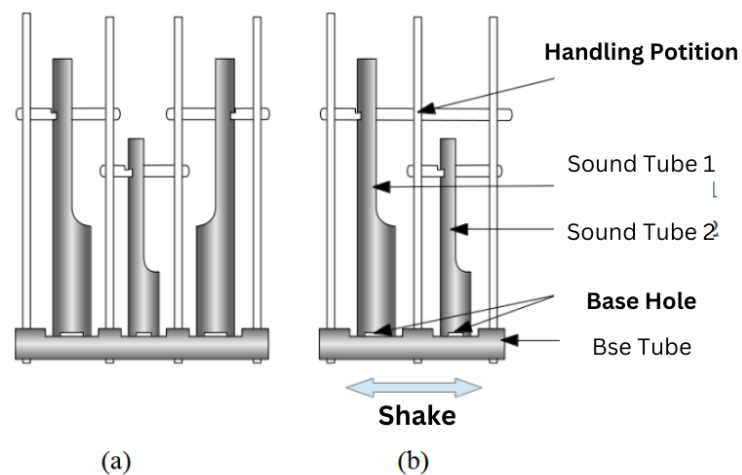
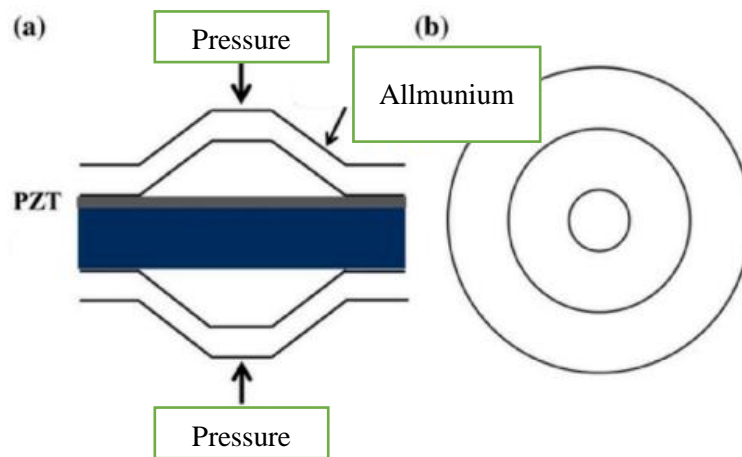

**Figure 1. (a) Angklung with 3 Tube (b) Angklung with 2 Tube**

## LITERATURE REVIEW

The research that has been done is to set the frequency parameters which are carried out for sound resonance by measuring, namely ethnomathematics in angklung and its

characteristics (Badruzzaman et al., 2022) There is also research on making Angklung robot control based on a microcontroller where the design is done with Arduino modules and controls based on Android (Murpratama et al., 2020), Another research is designing an angklung robot using esp8266 and android (Dwi et al., 2019), Another research is regarding the Angklung smart band implementation of the IoT game of angklung for the elderly in Thailand which shows that it can help in providing assistance in playing angklung to angklung users at an elderly age (Hiranpanthaporn et al., 2022). Tone changes are considered a form of harmonization, as can be seen from several previous studies. So that the number of beats becomes the most important part in seeing how harmonization can be formed in angklung playing.



**Figure 2. Structure (a) Piezoelectric Side View, (b) Piezoelectric Upside**

Supporting components in getting vibrations are using sensors for reading beats. The sensor used is a vibration sensor, namely a piezoelectric sensor that generates power that can be used for low-power electronic devices. Electronic devices are the most important part of today's technology, and the need for consumption energy is also high. so that's way needed a component of low power energy. The power generated from piezoelectric sensors can be used to drive small-scale wireless devices, such as wireless sensor networks and usable electronic devices (Sawane & Prasad, 2023). In an era of progress in the development of microfabrication technology, it is possible to optimize microelectronic circuits for the integration of miniature components, such as sensors or actuators in a complete and effective volume, making it possible to form small, medium, and large production scales. The depiction structure of the piezoelectric component is shown in Figure 2.

In the process of eliminating noise or interference is done using the Kalman Filter algorithm. The Kalman Filter algorithm is one that is widely used for noise filtering and for estimating the system state. The Kalman Filter was proposed by R. E. Kalman in 1960 and is often referred to as the Least Mean Squares Estimator. Some of the uses of the Kalman Filter are estimating state (variables), sensor noise filters (reducing sensor noise by estimation), several applications in robot control, battery management systems, improvements to image processing, improvements to object tracking. The use of this algorithm has the advantage of being light in computation so it only requires a little memory, besides that it can handle noise well, can estimate state, and can work at all frequencies.

## METHODS

The melodies of angklung consist of a large sound tube with a basic tone, as well as a small tube with an octave higher pitch as an amplifier. The design and configuration the Smart of Angklung operated in two models, namely the composition of songs mode and the arrangement of tones mode. The tube length and the tube diameter affect the sound intensity, that the smaller the tube diameter and the shorter the tube length, the sound intensity produced increases. Sound intensity is also proportional to the frequency that the higher the frequency then the greater the sound intensity produced. In the process of eliminating noise or interference is done using the Kalman Filter algorithm. The Kalman Filter algorithm is one that is widely used for noise filtering and for estimating the system state.

The Kalman Filter was proposed by R. E. Kalman in 1960 and is often referred to as the Least Mean Squares Estimator. Some of the uses of the Kalman Filter are estimating state (variables), sensor noise filters (reducing sensor noise by estimation), several applications in robot control, battery management systems, improvements to image processing, improvements to object tracking. The use of this algorithm has the advantage of being light in computation so it only requires a little memory, besides that it can handle noise well, can estimate state, and can work at all frequencies. Scheme of system measurement can be shown in figure 3 and figure 4.

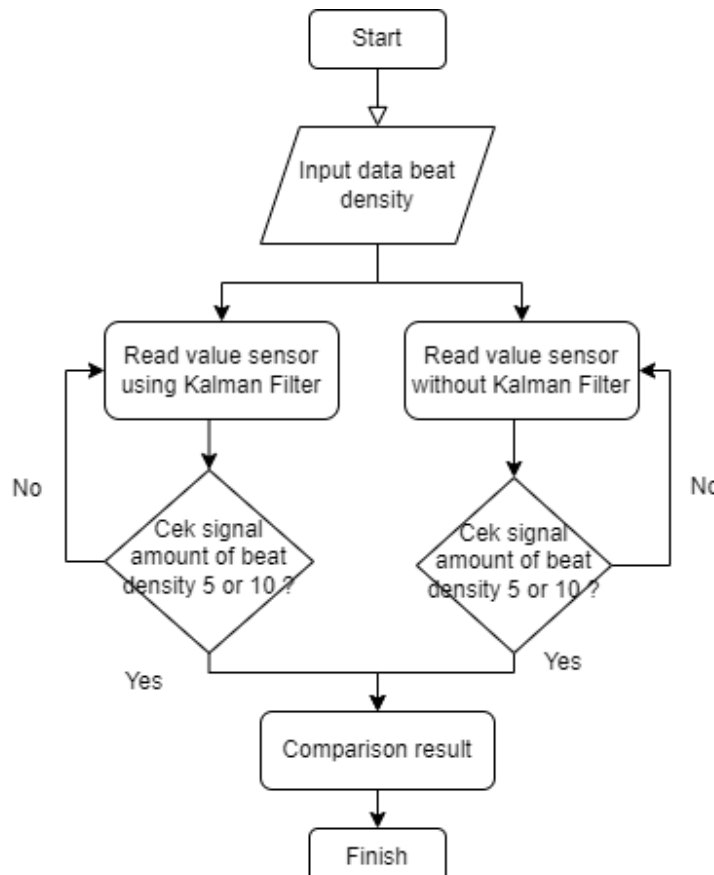
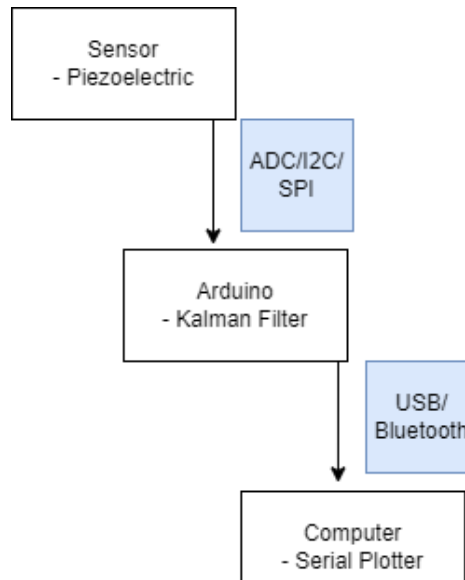

Figure 3. Flow Chart



**Figure 4. System Block Diagram**

The system equation on the Kalman Filter is assumed to be a linear system. Kalman Filter minimizes the squared error of the average estimate for a stochastic linear system using a linear noise sensor. It also minimizes the squared function estimation error for a linear dynamic system with white measurement and noise interference. Serves to estimate the state of a dynamic system and also to analyze system performance (Ma'arif et al., 2019). There are various types of Kalman Filters, such as standard Kalman Filters, Extended Kalman Filters, Unscented Kalman Filters, and Ensemble Kalman Filters. The Standard Kalman Filter is the simplest while the other types are modified for more complex tasks. Ideally, all noise from sensor readings should be canceled for high sensitivity sensors. However, it is nearly impossible to remove all noise because it occurs due to the nature of the external environment. Other options available are to reduce noise or to isolate noise from real measurement data. Kalman Filter has two sections, a prediction section and an update section. The standard Kalman Filter equation is shown in (1) – (5).

a. Prediction

The process of determining the value of a sensor from the presence of an estimator approach is used based on the following equation

$$\hat{x}_{t|t-1} = F_t \hat{x}_{t-1|t-1} + B_t u_t \quad (1)$$

$$P_{t|t-1} = F_t P_{t-1|t-1} F_t^T + Q_t \quad (2)$$

Where  $x$  is estimated state,  $F$  is state transition matrix,  $u$  is control variables,  $B$  is control matrix,  $P$  is state variance matrix,  $Q$  is process variance matrix.  $t|t$  is current time period,  $t-1|t-1$  is previous time period, and  $t|t-1$  is intermediate steps.

b. Update

Changes in value to get a real value then the need for the following calculations

$$\hat{x}_{t|t} = \hat{x}_{t|t-1} + K_t(y_t - H_t\hat{x}_{t|t-1}) \quad (3)$$

$$K_t = P_{t|t-1}H_t^T(H_tP_{t|t-1}H_t^T + R_t)^{-1} \quad (4)$$

$$P_{t|t} = (I - K_tH_t)P_{t|t-1} \quad (5)$$

P is state variance matrix, Q is process variance matrix, y is measurement variables, H is measurement matrix, K is Kalman gain, R is measurement matrix, t|t is current time period, t-1|t-1 is previous time period, and t|t-1 is intermediate steps.

c. Modification Kalman Filter

Equations (1) to (5) can be referred to as the standard Kalman Filter system model where the ultimate goal of implementing the algorithm has not been determined. Therefore, the standard Kalman Filter system model can be modified based on the objectives to be designed and adjusted for how complex the system is being solved. In implementing the standard Kalman Filter algorithm so that it can be used to reduce noise from piezoelectric sensor readings, some adjustments are required or adjustments to these conditions. These adjustments are as follows.

Predicting the state At this stage, adjustments are made to equation (1) by giving a value of  $F_t = 1$  because there is no state transition. Thus, reducing the input component of the  $B_t$  system because the system used does not have a  $u_t$  input. sales are then converted into equation (6).

$$x_{t|t-1} = x_{t-1|t-1} \quad (6)$$

Predicting error Because  $F_t = 1$ , equation (2) can be formulated as equation (7).

$$P_{t-1} = P_{t-1|t-1} + Q_t \quad (7)$$

Updating the state value from equation (3), with a value of  $H_t = 1$  because the sensor data to be filtered only consists of one sensor reading. Therefore, the equation can be formulated as equation (8).

$$P_{t-1} = P_{t-1|t-1} + Q_t \quad (8)$$

Calculating the gain of the Kalman Filter Because  $H_t = 1$ , equation (4) can be formulated as equation (9).

$$K_t = P_{t|t-1}(P_{t|t-1} + R)^{-1} \quad (9)$$

Updating the error value because  $H_t = 1$ , equation (5) is formulated into equation (10)

$$P_{t|t} = (1 - K_t)P_{t|t-1} \quad (10)$$



## RESULTS AND DISCUSSION

### Results

The design of the sensor system and Arduino is placed according to the desired data collection conditions. Based on the output of a tone or sound, the angklung base hole on the large and small tube is placed with a piezoelectric sensor with a sensor diameter of 27 mm. Then connected with a resistor with varying values from 10 kilo ohm up to 1 mega ohm. The process of placing the resistor is used to eliminate the noise value generated by the piezoelectric sensor. This condition is connected to the microcontroller, namely Arduino, which will read the results of the signal given by the sensor according to the beat being tested. Details of the implementation setup for the beat density reader design can be seen in Figure 5. Sensor installation is done on the bottom tube which will get pressure when the angklung is in motion. The sensor is placed on one side with a total of two sensors to read when there is movement both on the large side of the tube and on the small side of the tube. Sensor 1 is used to see the value of the number of changes that occur in the small tube and sensor 2 is used to see the pressure changes that occur in the large tube. But this experiment, it was carried out by analyzing sensor 1 due to its frequent use in the sounding of angklung tones. Before entering the Arduino microcontroller, a resistor is inserted between the positive and negative terminals. The analog signal will be read by the microcontroller by eliminating the noise that arises.

### Discussion

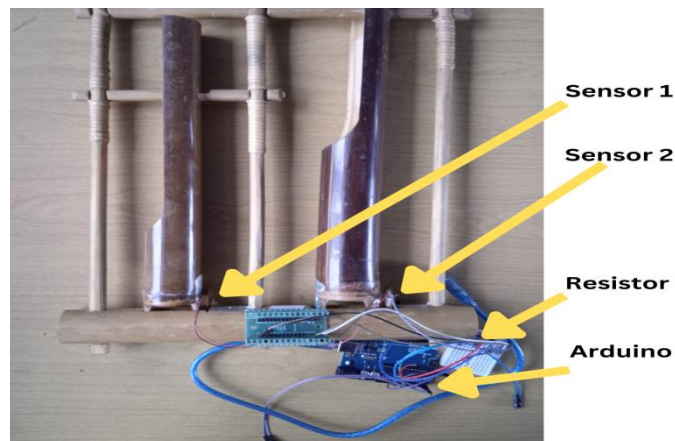

#### a. Beat density results

In the sensor readings, measurements were made in the experiment ten times. The experiment was conducted to measure the implementation of the angklung beat density. Experiments were carried out without using the Kalman filter (KF) algorithm and using it. The first experiment was carried out by manually tapping the angklung with five beats. This is done to measure the concept of beats with low patterns or with weak hitting conditions so as to get a low sound result as well. Apart from that, 20 beats were also carried out which would be read which was done to get results for punches with a long tone or rhythm or a greater hitting speed. In table 1 there are results from measuring the beat in five beats with ten trials.

The application is carried out in a piezoelectric sensor using a Kalman filter and not using a Kalman filter. The results of the number of beats that are read produce a number

of beats that are more than five beats due to noise from the sensor. To get the appropriate number of beats, it is necessary to adjust the value of the resistor and use a noise filter. The expected number of beats is five, but the results obtained are the smallest number of beats, namely seven beats without using KF, while for sensors that use KF a minimum number of beats is produced six number of beats. The average obtained for beats not using KF is 9.3 beats and those using KF are 7.8. It is felt that it is still far enough to get signal results that are protected from sensor noise.

**Table 1. Beat measurement in 5 beats of the angklung**

Experiment	Sensor Without KF 5 beats	Sensor Using KF 5 beats
1	8	9
2	10	7
3	7	6
4	12	8
5	10	9
6	9	6
7	7	7
8	7	8
9	14	9
10	9	9
<b>Average</b>	<b>9.3</b>	<b>7.8</b>

**Table 2. Beat measurement in 20 beats of the angklung**

Experiment	Sensor Without KF 20 beats	Sensor Using KF 20 beats
1	29	22
2	26	23
3	23	26
4	22	27
5	24	24
6	23	22
7	26	20
8	24	22
9	29	23
10	27	23
<b>Average</b>	<b>25.3</b>	<b>23.2</b>

b. Signal results

Other observations that need to be made are the signal results displayed using a serial monitor. The conditions obtained for a piezoelectric sensor signal without using a resistor can be seen in Figure 6. This shows the change between the x-axis of the signal time and the y-axis of changes in the sensor's analog signal value. It can be noticed that the change occurs from 0 to 200, 400, and reaches up to 1000. The change condition is an increase in value due to noise in the signal. So it is necessary to improve the signal so



that a fixed value is obtained or there is no change in noise. Figure 6 in side right is not much different from the previous image. The signal without a resistor using KF also has the dynamics of changing numbers when given a tap on the sensor from 0, 100, and 600. This is much smaller when implementing a KF filter with the number changing when given a tap on the sensor at only 0, 100, and 150. So the effectiveness of the KF algorithm is quite good with lower results without the KF algorithm being applied. In changing the results by using a resistor of 1 Mega ohm, a stable value is obtained, namely starting from the baseline number 0 which is fixed before being given a knock. In figure 7 changes occur when the beat is given, the value obtained from the experiment in five beats without KF where the signal noise does not change significantly from the value when the beat is given changes the analog value of 0, 4, and 16 analog values. Besides that, the value that is seen in the signal still contains noise numbers 0 and 1. Then the response from the beat is also seen to be more due to the noise. In Figure 7 at side right the changes occur better because using KF the results obtained are waves that are not distorted by noise. The change in value that occurs when a beat is given starts from values 0 and 2. This is relatively very small for sensor readings. From these conditions to pay attention to changes in beats, threshold limits are determined in the noise filtering process.

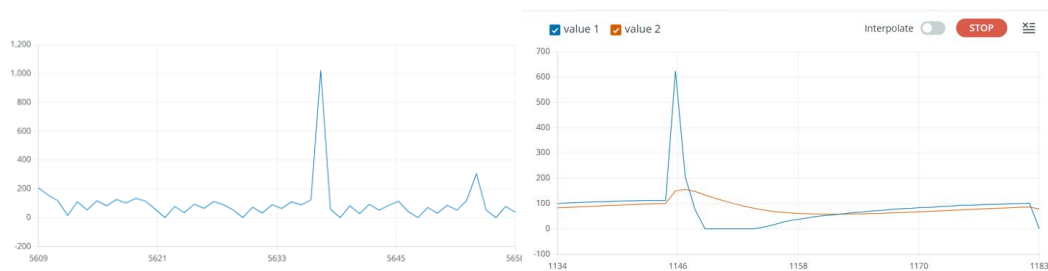

**Figure 6. Signal without resistor and signal without resistor using KF**

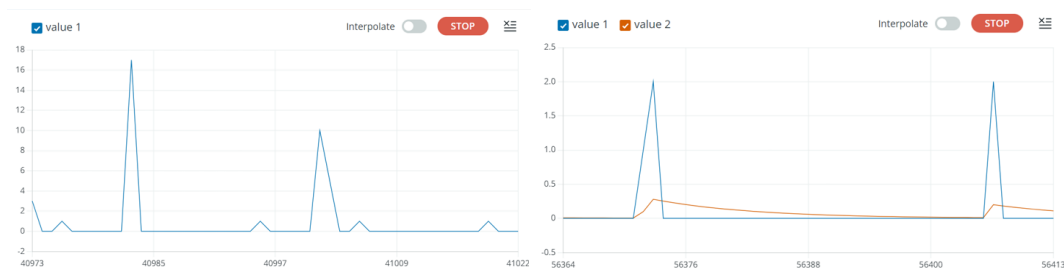

**Figure 7. Signal 5 beats without KF and signal 5 beats using KF**

## CONCLUSION

Based on these results, it can be concluded that beat density the angklung with arduino and piezoelectric sensors using the Kalman filter application to reduce sensor noise can provide

good value in its application. The change in value occurs when the resistor is replaced to correct for the number of taps and the distorted signal is better. The application of the Kalman filter provides a smaller value change in density so that the signal can better filter changes. The significance of the value is also seen in changes when using the Kalman filter for read analog values. In future studies, a comparison of several methods for eliminating noise will be carried out.

Conditions that obtain the value of the beat can be produced in the form of harmonization in angklung playing. Changes in the number of beats that result in obtaining the value obtained must be truly pure to be an assessment point for harmonization. The strength of the beat and the distortion of values are used as points of analysis in making harmonization formed. Technological developments in measuring changes that occur in tones and sounds are important to get harmonization.

## REFERENCES

- Badruzzaman, F. H., Purwanda, E., Harahap, E., Erfiyana, E., Studi Manajemen, P., Tinggi Ilmu Ekonomi STEMBI Bandung Business School, S., Studi Akuntansi, P., Studi Matematika, P., Islam Bandung, U., Studi Manajemen Pendidikan Islam, P., & Tinggi Agama Islam Badruzzaman, S. K. (2022). *Etnomatematika Dalam Angklung dan Karakteristiknya Ethnomathematics in Angklung and Its Characteristics*. 21(1).
- Dwi, B., Putra, R., Purno, A., & Wibowo, W. (2019). Perancangan Kontrol Alat Musik Angklung Menggunakan ARDUINO, ESP8266 Dan ANDROID. In *Januari*.
- Hiranpanthaporn, S., Phoasavadi, P., & Cooharajanane, N. (2022). Angklung Smart Band: An IoT-Based System to Support Music Activities for Elderly in Thailand. *2022 IEEE European Technology and Engineering Management Summit, E-TEMS 2022 - Conference Proceedings*, 142–147. <https://doi.org/10.1109/E-TEMS53558.2022.9944469>
- Ma'arif, A., Iswanto, I., Nuryono, A. A., & Alfian, R. I. (2019). Kalman Filter for Noise Reducer on Sensor Readings. *Signal and Image Processing Letters*, 1(2), 11–22. <https://doi.org/10.31763/simple.v1i2.2>
- Murpratama, E., Sunarya, U., & Novianti, A. (2020). ANGKLUNG ROBOT CONTROL SYSTEM BASED ON MICROCONTROLLER. *Jurnal Elektro Dan Telekomunikasi Terapan*, 6(1), 734. <https://doi.org/10.25124/jett.v6i1.1876>
- Satya, D., & Budi, U. (2014). *Modifikasi Angklung Sunda*. <http://malvanabilla.blogspot.co.id/2014/03>
- Sawane, M., & Prasad, M. (2023). MEMS piezoelectric sensor for self powered devices A review. *Materials Science in Semiconductor Processing*, 1–31.