

## Improved Microcontroller-Based 3 Phase Induction Motor Protection From A Variety Of Interruptions

Efri Wildan Hafiz, Adi Sastra P. Tarigan, Solly Aryza

Email: [wildanhafize@gmail.com](mailto:wildanhafize@gmail.com)

Universitas Pembangunan Panca Budi

### ABSTRACT

*Different types of human labour in the contemporary era of globalization rely on electronic tools like 3-phase induction motors. The usage of a 3-phase induction motor in this investigation is essential for synchronized gait and function. Due to differences in the R, S, and T phase angles, which result in an uneven load overload in the electricity distribution system, voltage changes between the three phases of the electrical energy system arise. Overvoltage, Undervoltage, Unbalanced Inter-Phase Voltage (unbalance voltage), Overload (overload), and Overheat are a few of the issues that might arise. In response to this conflict, a three-phase induction motor protection system was developed.*

**Keywords:** *Unbalanced, Sensors, Magnetic Contractors, Disturbances, Safety Systems and Microcontrollers.*

### INTRODUCTION

Almost all human activities in the contemporary era of globalization rely on electric devices like 3-phase induction motors. According to their function and the advantages of induction motors, 3-phase induction motors are crucial for use and are widely employed in international business. They are typically used to power manufacturing machinery like the assembly of heavy equipment. Alam Alif Malkarim previously studied the analysis of voltage imbalance and temperature rise in a three-phase induction motor due to single-phasing interference in a work that was published in 2016. When a single-phasing disturbance occurs at zero and loaded circumstances, the design aims to use a proxy brake. According to the test results, the single-phasing impact caused a voltage imbalance of 3.64% at zero load to 6.30% at full load, while the single-phasing period output power was 36.46 Watts to 573.62 Watts, compared to 34.06 Watts to 417.04 Watts in normal terms. In comparison to normal terms, the single-phasing time efficiency ranges from 21% to 70%. When the motor is not under load, the temperature rises to 35.40°C, and when it is, it rises to 57.74°C utilizing the 28°C temperature in the usual state.

The monitoring and safety system for a 3-phase induction motor based on the Atmega 8535 microcontroller was the subject of Sahdan Ashari's study from 2015. The goal of this study was to safeguard the operation of a 3-phase induction motor based on disturbances such as overload, undervoltage, overvoltage, overload, unbalanced phase voltage, reduced rotation speed, and overheating. Additionally to the security system, a monitoring system was developed utilizing MATLAB R2009a GUI (graphical user interface) programming. According to the results of the testing, tripping takes 4.14 seconds to set a current of 1 A using a current setting of 5 A, and tripping takes 7.3 seconds to set a current of 2 A using a current setting of 5 A. According to the test results, there are 3.44% homogenous mistakes, which causes the average tripping time for overload safety to be 96.56%.

Based on the issue, this research aims to detect, protect, predict, and monitor whether there is a disturbance in a 3-phase induction motor, which consists of various hardware and software designs. The protection testing stages are carried out using the method of assigning a set point value to the

voltage sensor. A protection system is designed based on various disturbances and monitoring using a microcontroller using a magnetic contactor that is connected DOL (Direct Online) in the motor's three-phase induction. This magnetic contactor will cut off when the time of a given disturbance exceeds the given set point value.

## LITERATURE REVIEW

### Induction Motor

Induction motors are composed of two main parts, the rotor, which rotates, and the stator, which is quiet, just like other kinds of electric motors.

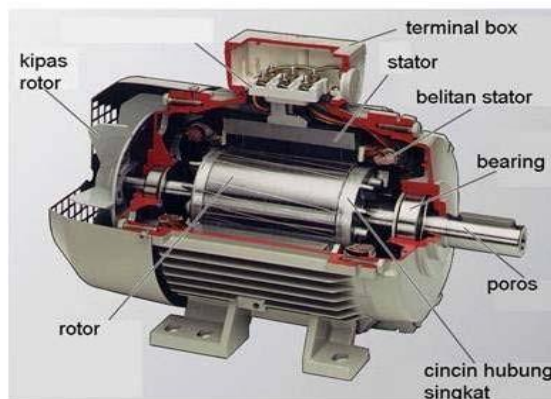

**Figure 1. Induction Motor**

### Magnetic Contactor

A switch that operates on the magnetism principle is known as a magnetic contactor or magnetic switch. This indicates that the switch operates when a magnetic field is present in the contact puller. The contribution of a pusher spring enables the magnet to perform as a puller and transform into a release of the contacts. Under typical operating circumstances, a contactor must be able to provide and assess current. As long as there is no disconnection, the regular functioning current is what is flowing. A coil in a contactor may operate at either DC or AC voltages. The contactor will vibrate if the voltage is less than 85% of the operating voltage in AC voltage. Figure 2 illustrates physical structures based on magnetic contactors.



**Figure 2. Magnetic Contactor**

### Temperature Impact of Unbalanced Voltage Disturbance

The National Electrical Manufacturers Association (NEMA) standard states that operating an induction motor over 5% is not advised since doing so results in an increase in current that the induction motor is unable to handle.

The stator, rotor, and iron core of an induction motor all experience an increase in temperature as a result of this increase in current. Equation represents the balanced voltage in an induction motor based on the Derating Curve equation :

$$1 + \frac{\text{the percentage by which the room's temperature increased}}{100} = \left(\frac{\% \text{ load}}{100}\right)^{-1.7}$$

Sedangkan untuk kondisi pencatuan tegangan tak seimbang untuk standar NEMA melakukan pendekatan persamaan 2.10 :

$$1 + \frac{2 (\% \text{ unbalance})^2}{100} = \left(\frac{\% \text{ load}}{100}\right)^{-1.7}$$

The equation above shows that, given particular imbalance situations, it is possible to compute the acceptable % Load. In other words, derating is necessary to satisfy standards based on the rise in motor temperature. Induction motors cannot function effectively when used in an unbalanced voltage environment. Increased heat loss in the motor, acoustic loss (noise), a drop in motor rating, and a shorter motor life are all the repercussions of the voltage imbalance in the induction motor's performance. The same motor current can flow despite the low line voltage that arises.

**METHODS**

A study was done in this instance to talk about the protection system's design with the goal of foreseeing and preventing disruptions like unbalanced voltage, overcurrent, overcurrent, overloaded, and overcharged. This process is broken down into two steps: designing the hardware and designing the software. In this part, the general operation of the three phase induction motor protection system, which is seen in Figure i3, is discussed.

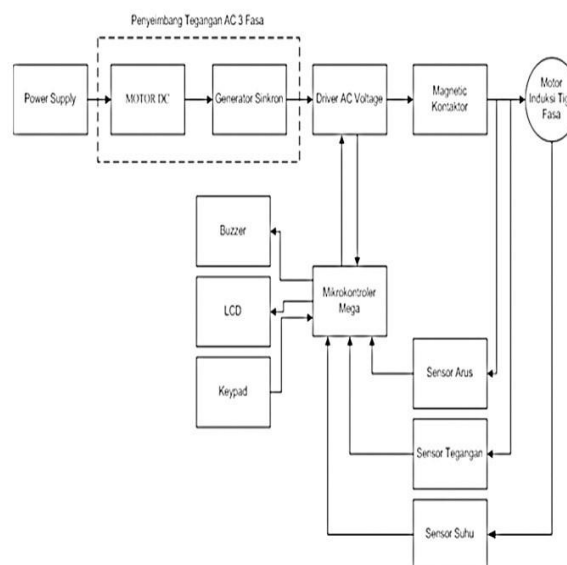

**Figure 3. Block Schematic of The Entire System**

The three-phase induction motor safety system's design flow is shown in the image above. Enter the system, which includes a power source for the DC motor. The synchronous generator's output is connected to the input of a three-phase induction motor so that protection tests can be performed on a three-phase induction motor when connected to star and delta for testing in an unbalanced state. The DC motor will be the initial mover that is connected to the synchronous generator in order to get a controlled rotation and get the voltage in unbalanced state.

The test also uses a contactor that serves as a switching or breaker that is sensitive to temperature, voltage, and current will open and close when disturbances occur in accordance with the setpoint value that has been set. This contactor protects against frequent disturbances like undervoltage, overvoltage, undercurrent, and overheat in an unbalanced state. Given, the results of all performed tests will be processed on the output signal and then transmitted to the microcontroller for LCD display. Figure 4 depicts the hardware layout used in this investigation.

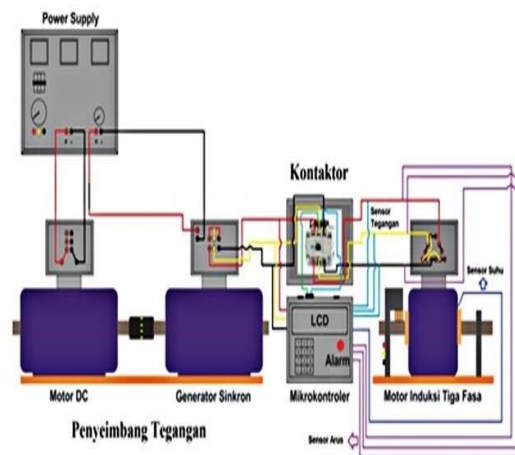

**Figure 4. Three Phase Induction Motor Protection System Overall Tool Design**

The overall circuit of Figure 5 can be understood as the three-phase induction motor protection system using a star and delta circuit, which aims to determine the performance of the tool that has been designed. The Mega microcontroller will control and monitor the circuit based on the overall circuit.

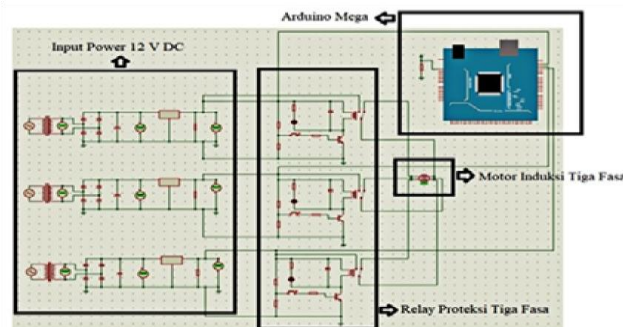

**Figure 5. Complete Circuit**

A three-phase induction motor is put through over current and over load protection testing when the load placed on it exceeds its capacity while maintaining a current setpoint value of 1 A. Mechanical loads that use a variable rheostat as a source of resistance variation safeguard against overcurrent and overload. This test aims to see the maximum temperature limit for the working time of a three-phase induction motor in an operating state with a maximum temperature limit setting of 40°C, by providing a load that is more than the capacity borne by the motor. This research must have the right structure and workflow. The following is a research flow chart which can be seen in Figure 6.

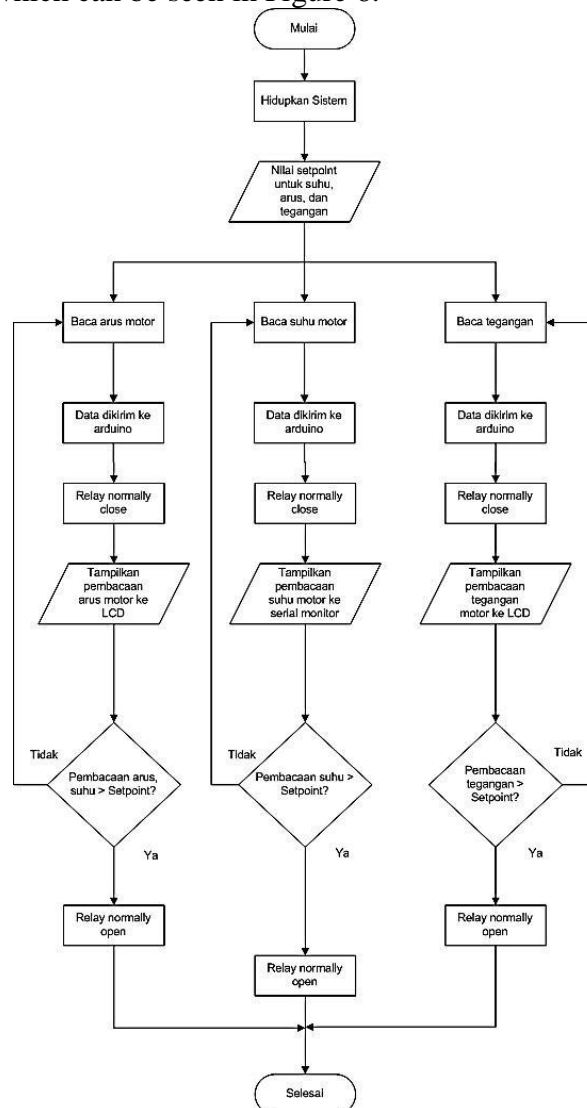

**Figure 6. Diagram of a system**

**RESULTS AND DISCUSSION**

**System Test for Protection**

Based on the concept and experiments that had been done, the test was conducted at the Panca Budi Development University. When there is unbalanced interference with a load of 1000 and up to 167 in phase R with a predetermined point value, the test is run with the voltage balanced at 380 V for each phase R, S, and T.

**Table 1. Data from the protection test when the voltage is unbalanced**

R ( $\Omega$ )	V <sub>out</sub> Motor Induksi Tiga Fasa (V)			I <sub>out</sub> Motor Induksi Tiga Fasa (A)			V <sub>out</sub> Beban Motor DC	RPM
	V <sub>1</sub>	V <sub>2</sub>	V <sub>3</sub>	I <sub>1</sub>	I <sub>2</sub>	I <sub>3</sub>		
	1000	140	139	166	0,89	0,90		
500	137	135	156	0,88	0,96	0,65	176,4	2628
333	135	137	143	0,95	1	0,68	168,5	2588
250	130	136	128	0,98	1,05	0,75	163,8	2533
200	123	128	120	1,04	1,07	0,77	156,0	2477
167	112	114	108	1,13	1,16	0,82	148,9	2421

Based on the test results, it is determined that when the motor is subjected to a load of 1000, the output voltage obtained is greater under the condition that the unbalance voltage variation is quite large between V<sub>1</sub>, V<sub>2</sub> to V<sub>3</sub>, and the output current value is decreasing, which is 0.63 A at I<sub>3</sub>, whereas when the load is varied by 167, the voltage obtained decreases under the condition that the unbalance voltage variation is sufficiently large at V<sub>1</sub>, V<sub>2</sub> to V<sub>3</sub>, and the value of the output current is. According to the results of the tests, when the unbalanced voltage condition exists, the source of resistance is given, the voltage generated increases and the current decreases. This is because the greater the source of resistance, the greater the load will be, and when the source of resistance is given, the voltage decreases. Because less resistance will be distributed among different loads when a smaller source of resistance is provided, the output will be lower and the output current will be higher as a consequence.

**Test for Over Voltage Protection**

A three-phase induction motor is given a variation of the fault value, and the test is run when the voltage is in a balanced condition of 380 V and an over voltage setpoint of 250 V to 200 V is provided for the tripping process. Based on the above explanation, the test results data are displayed in Table 2.

**Table 2. Test Results for Data Protection When Over Voltage**

Set Point (V)	V <sub>out</sub> G Setelah Dibebani (V)	V <sub>out</sub> L-N Motor Induksi Tiga Fasa (V)			I <sub>out</sub> Motor Induksi Tiga Fasa (A)			Kondisi	RPM
		V <sub>1</sub>	V <sub>2</sub>	V <sub>3</sub>	I <sub>1</sub>	I <sub>2</sub>	I <sub>3</sub>		
250	349	228	207	264	1,25	1,24	0,80	Trip	2664
240	331	208	189	244	1,06	1,09	0,67	Trip	2637
230	323	197	196	236	1,03	1,02	0,66	Trip	2617
220	314	191	180	222	1,00	1,02	0,65	Trip	2574
210	304	182	185	217	0,98	0,96	0,65	Trip	2456
200	302	181	175	206	0,98	1,12	0,60	Trip	2262

According to test results, when a synchronous generator is loaded with 349 V and the voltage set point is 250 iV, the output voltage value is higher due to the conditions of the over voltage variation being fairly far between V<sub>1</sub>, V<sub>2</sub>, and V<sub>3</sub>, which cause the induction motor to trip.

At output voltage V<sub>3</sub>, which is 264 V, there are three phases. At output current I<sub>1</sub>, which is 1.25 A, the output voltage is increasing, however when the voltage set point value is 200V with a synchronous generator voltage source when it is loaded with 302V, the voltage value obtained falls quite a bit with the over voltage condition at V<sub>1</sub>, V<sub>2</sub> versus V<sub>3</sub>, and the output current value is getting lower, which is 0.60 A at I<sub>3</sub>. From the tests that have been conducted when the over voltage condition is concluded that the more the voltage source on the synchronous generator is supplied, the greater the voltage value obtained, Due to the fact that the over voltage test does not employ a source of resistance and a load on a three-phase induction motor, the output current will be lower.

### Overheating Protection Test

In tests that were conducted, a voltage source of 380 VAC from a synchronous generator with a set point of voltage of 250 VAC line to neutral and a current of 4 A was not used when the motor was operating at its usual temperature. The rotor of a three-phase induction motor becomes hot and reaches a temperature of 40 C when an induction motor is operating and a DC motor load is applied with a variation of the resistive variable resistance source at each test that attempts to oppose the direction of rotation of the rotor. The measurement results from the tests are shown on the LCD panel, According to tests, when the temperature on the three-phase induction motor reaches 40°C, the data is sent and processed by the microcontroller and displayed on the serial monitor screen display. Based on the explanation provided above, the test results, when the temperature on the three-phase induction motor has exceeded the set point value that has been determined with tripping conditions, the LCD screen display shows over heating and the motor stops operating when given a disturbance.

**Tabel 3. Data from Overheating Protection Test Results**

R ( $\Omega$ )	Pengukuran Sensor Suhu Pada Layar Display ( $^{\circ}C$ )	I <sub>our</sub> Motor Induksi Tiga Fasa Pada Layar LCD (A)			I <sub>our</sub> Motor Induksi Tiga Fasa Pada Tang Ampere (A)			Waktu (S)	Ket	RPM
		I <sub>1</sub>	I <sub>2</sub>	I <sub>3</sub>	I <sub>1</sub>	I <sub>2</sub>	I <sub>3</sub>			
1000	40,55	1,02	1,10	0,71	1,11	1,02	0,58	630	Trip	2963
500	40,00	1,26	1,37	0,79	1,27	1,42	0,73	522	Trip	2837
333	40,50	1,47	1,57	1,05	1,52	1,59	0,77	420	Trip	2660
250	40,75	1,58	1,44	1,09	1,57	1,62	0,82	390	Trip	2674
200	40,45	1,71	1,74	1,24	1,85	1,76	1,24	360	Trip	2590
167	40,65	1,86	1,81	1,30	1,87	1,86	1,27	318	Trip	2371

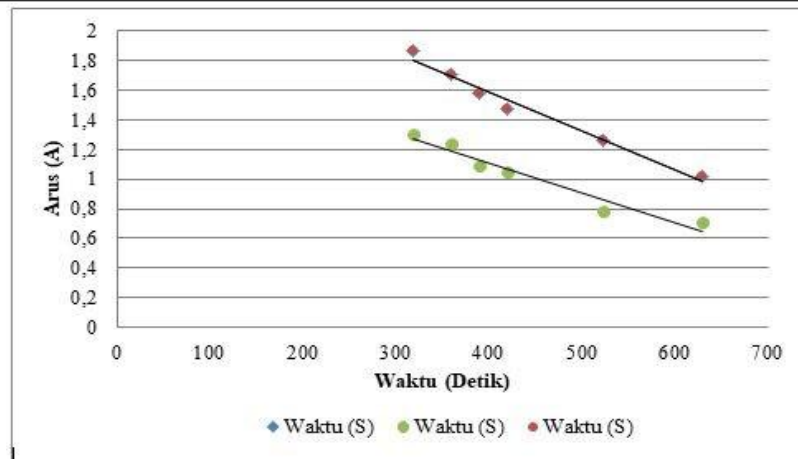

**Figure 7. Graph Comparing the Current Output of the ACS712 Current Sensor Against Time in Seconds**

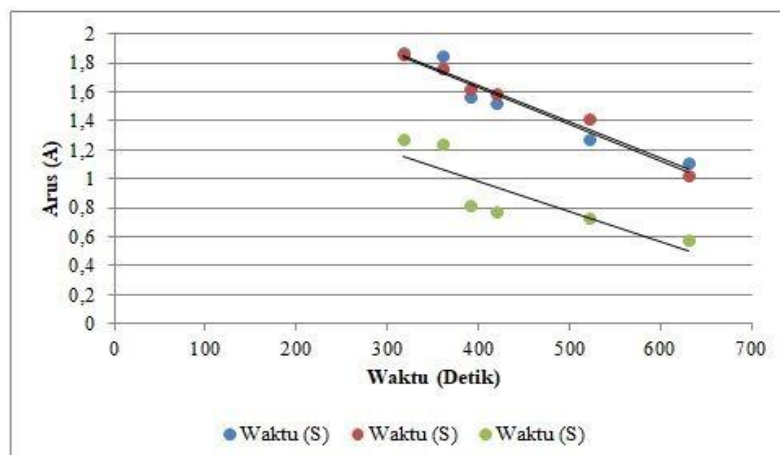

**Figure 8. Graph of Output Current Comparison with Measuring Tools Against Time in Seconds**



According to Figure 8, the temperature increase detected by the K-type thermocouple sensor under overheat conditions happens more quickly when compared to external resistance fluctuations, at a temperature measurement with a resistance of 167 and a current value detected by a current sensor.  $I_1 = 1.86$  A,  $I_2 = 1.81$  A, and  $I_3 = 1.30$  A for ACS712. Additionally, measurements shown in Figure 8 were made utilizing ampere pliers and measuring tools with a resistance of 167 and measured current values of  $I_1$  1.87 A,  $I_2$  1.86 A, and  $I_3$  1.27 A. When the resistive variable source resistance is given starting from the highest range to the lowest range based on the results of temperature measurements obtained at 40.65 C with heating time of 318 seconds, the value of the current and heat generated by the rotation of the three-phase induction motor in the opposite direction of rotation with the DC motor is given.

Based on the preceding argument, it can be inferred that the three-phase induction motor will be more heavily burdened by the load on the DC motor the higher the resistance supplied, the more current flowing will be divided into various loads, and vice versa if the resistance is less.

## CONCLUSION

The conclusions of this research are

1. In the case of disruptions, the three-phase induction motor protection system can operate effectively, protecting and monitoring in line with the specified set point value.
2. According to testing of the three-phase induction motor protection system, which is connected in star and delta, the test results for the unbalance voltage are  $V_1$  140 V;  $V_2$  139 V;  $V_3$  166 V; for the over voltage are  $V_1$  228 V;  $V_2$  207 V;  $V_3$  264 V; for the over current are  $A_1$  104 A;  $A_2$  107 A; and  $A_3$  0.77 A; for the over load on resistance are 333, 250, 200, and 167.
3. The three-phase induction motor is overloaded with tripping circumstances based on the findings of the overcurrent fault test on one of the  $I_2$  currents of 1.05 A, with a resistance of 250, since the more resistance provided, the more the current flowing would be divided into various loads. Likewise, if the resistance is lower, additional loads will split the current flow less.

## REFERENCES

- Aryza, S., Irwanto, M., Khairunizam, W., Lubis, Z., Putri, M., Ramadhan, A., Hulu, F. N., Wibowo, P., Novalianda, S., & Rahim, R. (2018). An effect sensitivity harmonics of rotor induction motors based on fuzzy logic. *International Journal of Engineering and Technology(UAE)*, 7(2.13 Special Issue 13), 418–420. <https://doi.org/10.14419/ijet.v7i2.13.16936>
- Aryza, Solly. (n.d.). *DESIGN SPEED ESTIMATION OF INDUCTION MOTOR DRIVES WITH DSP ( DIGITAL SIGNAL PROCESSING ) BASED ON NEURAL NETWORK. 1.*
- Depeursinge, A., Racoceanu, D., Iavindrasana, J., Cohen, G., Platon, A., Poletti, P.-A., &

- Muller, H. (2010). Fusing Visual and Clinical Information for Lung Tissue Classification in HRCT Data. *Artificial Intelligence in Medicine*, 15, ARTMED1118. <https://doi.org/10.1016/j>
- Deptt, E., & Jabalpur, J. E. C. (2013). *CONTROL OF STARTING CURRENT IN THREE PHASE Sharda Patwa. 01*, 27–32.
- Ilyas, R. A., Sapuan, S. M., Ishak, M. R., & Zainudin, E. S. (2018). Development and characterization of sugar palm nanocrystalline cellulose reinforced sugar palm starch bionanocomposites. *Carbohydrate Polymers*, 202, 186–202. <https://doi.org/10.1016/j.carbpol.2018.09.002>
- Leevijit, T., Prateepchaikul, G., Maliwan, K., Mompiboon, P., & Eiadtrong, S. (2017). Comparative properties and utilization of un-preheated degummed/esterified mixed crude palm oil-diesel blends in an agricultural engine. *Renewable Energy*, 101, 82–89. <https://doi.org/10.1016/j.renene.2016.08.047>
- Misdawita, & Sari, A. A. P. S. (2013). Analisis Dampak Pengeluaran Pemerintah Di Bidang Pendidikan, Kesehatan, Dan Pengeluaran Subsidi Terhadap Kemiskinan Di Indonesia. *Jurnal Ekonomi & Kebijakan Publik*, 4, 147–161. <https://doi.org/10.22212/JEKP.V4I2.50>
- Santika, T., Wilson, K. A., Budiharta, S., Law, E. A., Poh, T. M., Ancrenaz, M., Struebig, M. J., & Meijaard, E. (2019). Does oil palm agriculture help alleviate poverty? A multidimensional counterfactual assessment of oil palm development in Indonesia. *World Development*, 120, 105–117. <https://doi.org/10.1016/j.worlddev.2019.04.012>
- Suryaputra P., A., Samopa, F., & Hindayanto, B. C. (2014). Klasterisasi Dan Analisis Trafik Internet Menggunakan Fuzzy C Mean Dengan Ekstraksi Fitur Data. *Jurnal Informatika*, 12(1), 33–39. <https://doi.org/10.9744/informatika.12.1.33-39>