

Design Build a Spider Robot Detector Fire Arduino based

M. Hafizul Furqon^{*1}, Prahenua Wahyu Ciptadi², R. Hafid Hardyanto³, Eko Harry Pratisto⁴

^{1,2,3} Department of Informatics Faculty of Science and Technology Universitas PGRI Yogyakarta
Indonesia

⁴ School of Management and Marketing, Curtin University, Australia

E-mail: * ¹hafiz87911@gmail.com, ²nusa@upy.ac.id, ³hafid@upy.ac.id, ⁴eko.harry@gmail.com

Abstract

Fire is an event that is not desired by every human being. Fires can cause significant losses, both material and life losses. Every fire process always causes a fire in a place or room where a fire occurs. A fire that is still not too big can be detected using a robot. Detection of the source of the fire in the kitchen room is still difficult because it is not yet known by the occupants of the house who are in another room or outside the house. Residents of the house have difficulty finding hotspots that are still small, so a robot is needed that can detect the presence of these hotspots. One of the robots that can be applied in this situation is the spider robot. This study aims to implement fire sensor technology to detect fire using Arduino. Methods of data collection using literature study and observation. The application development phase includes analysis, system design, implementation, and testing. This program is implemented using ultrasonic sensors, wi-fi modules, servos, and fire sensors. Ultrasonic sensors as a protection system from robots and IR flame sensors as sensors to detect fire. The spider robot can detect fire and provide warnings through sound alarms and can provide notifications via messages in the WhatsApp application. The fire detection robot made can detect a fire by notifying WhatsApp messages and alarms when the robot detects fire. The test results show the tool can run well. This can be proven by the value of the test results that have been carried out

Keywords — Fire Detection, Arduino, Spider Robot

1. INTRODUCTION

Technology has changed so rapidly that it can be used for life in society. Creative and innovative thinking is needed to be able to take advantage of this technology. One of the things that utilize technology in its manufacture is the manufacture of robots. One of the situations that require a robot is when there is a high risk of danger, for example, the fire that causes a fire. Fire is an event that is not wanted by every human being. Fires can cause huge losses, both material and life losses. Every fire process always causes a fire in a place or room where a fire occurs (Jannah, 2017).

It takes a tool to detect and know the source of the fire. A fire that is still not too big can be detected using a robot. Detecting the source of the fire in the kitchen room is still difficult because the occupants of the house who are in another room or are outside the house have not noticed it yet. Residents of the house have difficulty finding small hotspots, so a robot is needed that can detect the presence of these hotspots. One of the robots that can be applied in this situation is the spider robot.

A spider robot is a robot that moves using 4 or 6 legs. Because the robot can be statistically stable by using 3 legs or more, the spider robot has high flexibility. Based on the description above, the writer will build an Arduino-based fire detection spider robot. With this spider robot, it is hoped that users can detect sources of fire that might cause fires in the house. The purpose of making this robot is to assist homeowners in giving a warning inside the house when a fire is detected.

2. RESEARCH METHODS

2.1. Object Study

In accordance with the title to be compiled by the author is about design build a spider robot detector fire-based, Arduino, then research This will design a robot to detect existing fire in a room. *The hardware* that will implement uses device Arduino Nano microcontroller, fire sensor, and ultrasonic sensor. Then Forgive information to occupants use an alarm that can beep when the robot succeeds detect existing source fire.

2.2. Robot Design

After getting a clear picture _ of a system that will make, a step furthermore is to do planning tool. Stages planning done For give description general clear, as well displays design get up complete to tool to be made.

2.2.1.1. Detector Block Diagram Design Fire

detection robots fire to have a principle that it will move Alone to detect hitch, at the moment it's a fire sensor too active. If at the time the robot moves the robot finds fire and voltage output detected by the fire sensor then the robot will stop, after it will alarm sounds and notifications WhatsApp messages received. How it works *flame detectors* capable Work with Good For catch the flame For prevent fire, that is with identity or detecting a flame which is detected by the presence of infrared and ultraviolet light spectrum with the use of later optical methods results detection That will continue to Microprocessor in the *flame detector* unit will Work For differentiate the light spectrum contained in the detected fire the with system *delays* for 2-3 seconds on the detector This so that capable detect source fire more early and possible No happen source of false alarms. Fire match fire/lighter can be detected from a distance of 80cm. The more big fire, the increasingly Far possible distance _ detected. Following This is a block diagram of the detection system fire.

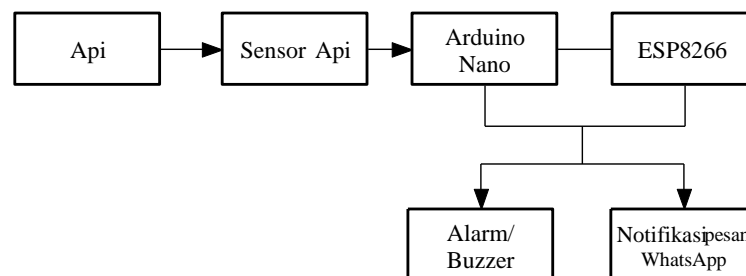

Figure 1. System Block Diagram Detector Fire

2.2.1.2. Designing the Physical Form of the Tool

The detector robot displays fire This is shaped like Spider 4 legs. On the robot body, there is a network consisting _ of 8 Servo Sg90, 1 Arduino Nano, Robot Spider Kit, 3 Fire Sensors, 3 Ultrasonic Sensors, 1 On Off Switch, and 1 Buzzer. The dimensions of the robot are 170 mm x 260 mm x 250 mm and have 4 control legs. The robot circuit is made from 1 piece of acrylic connected 3 mm thick with the bolt. Following is the design detection robot circuit fire.

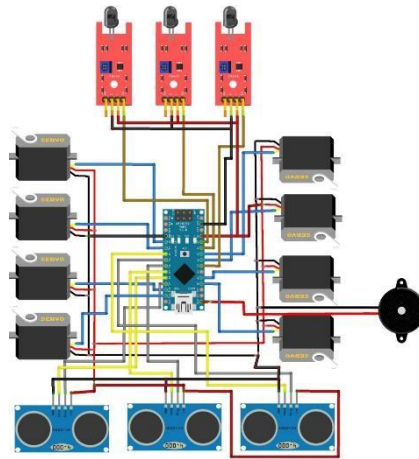

Figure 2. Network Detection Robot Components Fire

2.2.1.3. Flow chart

A *flow chart* or flow charts show the internal process flow system. Draft *flowchart* on design-build a detection robot fire to be made This can be seen in figure 3.1.

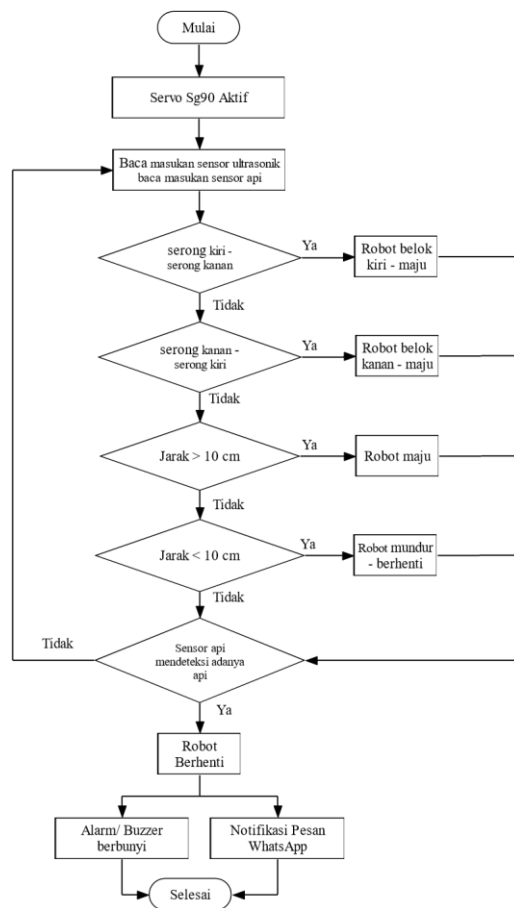

Figure 3. Flowchart System

2.2.1.4. WhatsApp Notification Design

Appearance system This is used as a *human interface* To facilitate the user in accepting notifications when detected exists fire in the room kitchen. Draft Appearance WhatsApp notifications will be shown in Figure 4 below this :



Figure 4 . Draft Appearance WhatsApp notifications

3. RESULTS AND DISCUSSION

The working principle of the arduino-based fire detection spider robot with wifi communication is that when the robot is connected to a battery source to supply power to the arduino, the arduino will immediately respond and carry out the commands that have been programmed in it. Then the wifi module will look for an active wifi device from the smartphone that has been programmed in it to make a connection. When the wifi is looking for devices and connecting, Arduino performs another command, namely an order to the servo motor to prepare to receive commands from the Arduino controller, and when it is connected the robot is ready to move forward, backward or turn according to the working principle of the sensor programmed in Arduino.

The Arduino-based fire detection spider robot here contains supporting components such as Arduino Nano technology, fire sensors, and ultrasonic sensors. The implementation of these components has been successfully carried out in the design of an arduino-based fire detection spider robot. The tool created can assist in providing information to residents/homeowners by using an alarm that can sound when the robot succeeds in detecting a source of fire and a WA notification (WhatsApp application) with the WA number that has been determined in the system. The WA application can receive notifications when the robot successfully detects fire. In designing this program using Arduino Nano which will read input from ultrasonic sensors and fire sensors. Ultrasonic sensors are used to detect obstacles in front of the robot, and IR flame sensors are used to detect fire. The following is a display of the fire detection spider robot which can be seen in the picture.

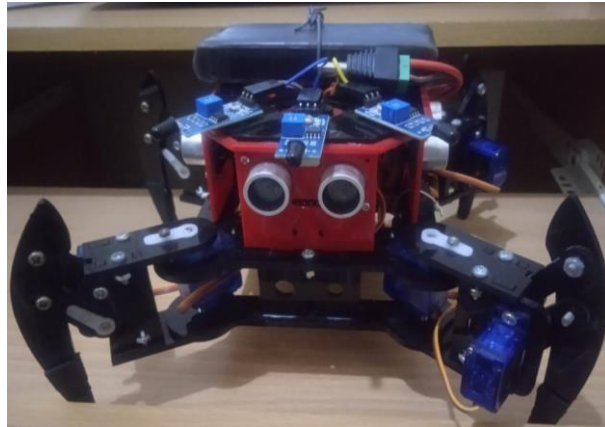

Figure 5. Fire Detecting Spider Robot

Table 1. Testing of the Fire Detecting Spider Robot

No	Activities Performed _	Description Activity	Expected Results	Actual Results	Test Status
1.	The user turns on the robot with connect plug the battery on the robot	Users can turn on the robots	plug battery function with Good For turning on and off the robot	Walking robots	Succeed
2.	The user turns on the source fire and runs robots	Robot walking and searching source file	Robots stop in accordance with the program ie when Already close to the source file	Robots stop	Succeed
3.	User closer source fire on the robot already turned on	Robots detect source fire and the alarm goes off	Alarms can beep in accordance with existing programs specify that If Already gotten to the source file	Alarm goes off	Succeed
4.	Users provide hindrance flat in front of the robot being walk	Robots detect the obstacle in front of him and turns dodge	sensors Ultrasonic will order the Robot to turn and dodge from hindrance If There is an obstacle ahead _	Robots turn dodge	Succeed

5.	User closer source fire on the robot already turned on	IR Flame can detect fire	IR Flame sensor can detect fire	Robots If detect fire	Succeed
			There is a fire in the room		

3.1. Excess

- Detection robot circuit fire made _ can use To detect fire and got give a warning form sound the alarm.
- In addition to the alarm as a warning, robots also get give warning through Message WhatsApp (WA) on the existing WA number set in the program.
- The suite tool made _ its own automatic system _ to detect fire so robots can look for the source of the fire in the robot room. _
- The battery used can be charged through the tool in a time short that is about 1 minute so that the user does No throw away time many For wait until the battery is full.

3.2. Lack

- Warning through WA messages sometimes has a constraint that is No sent message when detected exists fire.
- Robots only can detect hindrances from the wall so If There is another barrier that is thinner than the wall then the robot stays walking.:

4. CONCLUSION

Once testing and program analysis, the obtained conclusion :

- Design-build a spider robot detector fire has to be successfully implemented. Data retrieved is ultrasonic sensor data, module wifi, servo, and fire sensor. An ultrasonic sensor as system protection from robots and IR flame sensors as sensors for detecting fire. Spider robots are capable detect fire at a distance as far as 30 cm through alarm sound and are able to give WA notifications that can be Received as fast as 2 seconds.
- Spider robot test results detector fire use Arduino nano shows tools and systems can walk with ok. this _ can prove with mark the results of the black box test performed. Trial results black box test with the answer " Yes " as much as 100% and " No " as much as 0%.

5. SUGGESTION

Research conducted by the author This Still Lots there is flaws and weaknesses, so Still needed development tools furthermore namely :

- next robot to be made better in matter warning through WA message so no Again have constraint No sent message when detected exists fire.
- Next robots can be developed in order to detect hindrances besides objects flat like a wall so that If There is another barrier that is thinner than the wall then the robot stays can dodge. t.

REFERENCES

- [1] Hermawan , I. (2016). Design and Manufacture Key Door House Using RFID with an Arduino -based Multi Reader . *Muhammadiyah University of Surakarta* , 147 , 11–40 .
- [2] Jannah, M. (2017). Design Build a Fire Smoke Detector using Arduino Uno Based MQ-2 Sensor . *University of North Sumatra* , 1–61 .
- [3] Nehru, F. (2018). Application of IoT (*Internet of Things*) on Arduino - Based River Water Level Checking . *Thesis (S1) Thesis, Muhammadiyah University Ponorogo* .
- [4] Putra, AR, & Susilo, A. (2018). Design and Implementation of Fire Robots Fire based Arduino Mega 2560 microcontroller . *Respati University of Indonesia* , 3 .
- [5] Rodiah , F. (2018). Filler Glass Automatic For Persons Blind Using Ultrasonic Sensors Arduino Uno based . *Yogyakarta State University* , 372 (2), 2499–2508 .
- [6] Sakti, B., Siregar , RH, & Hafidh . (2018). Design Build Finer (Fire Point Detector on Isolation Cable) as an Effort Tool Prevention Happening Fire At Home stay . *Journal Work Electrical Engineering Scientific* , 3 (2), 30– 38. .
- [7] Salahuddin, Mellyssa , W., & Azman. (2018). Spider Robot Design Detector Fire based ATMEGA32 microcontroller . *Elkawanie* , 4 (1), 79–88. <https://doi.org/10.22373/ekw.v4i1.3033>
- [8] Saputra , DH, Nabilah , N., Islam, HI, Pradipta , GM, Atsaurri , SS, Kurniawan, A., Safutra , H., Arif , A., & Irzaman , I. (2016). *Detector Model Creation Fire Arduino Uno Based With Output SMS Gateways* . V , SNF2016-CIP-103-SNF2016-CIP-108. <https://doi.org/10.21009/0305020120>
- [9] Setyaningsih , E., Prastiyanto , D., & Suryono . (2017). Use of Photodiode Sensors as System Detection Fire on a Vertical Take-Off Landing (VTOL) Flying Vehicle . *Journal of Electrical Engineering* , 9 (2), 53–59. <https://doi.org/10.15294/jte.v9i2.11155>
- [10] Utomo , MSB (2018). Open Close System Prototype Door Automatic On Dam For Arrange Water Level Level based on Arduino UNO. *Muria Kudus University* .
- [11] Wardani , LE (2019). Prototype Giving Feed Chicken arduino based . *Yogyakarta State University* , 8 (5), 55.
- [12] Wicaksana , A. (2018). Measuring Instrument Design Turbidity in Pool Water Using Optocoupler (Turbidity Sensor) Based on Arduino. *University of 17 August 1945 Surabaya* , 51 (1), 51.