

Design and Build A Portable Smart Trash With Metal & Non Metal Separator

St. Nurhayati Jabir^{*1}, Wahidah², Sari Wahyuni³

^{1,2,3} Department of Machining System Automation, ATI Polytechnic, Makassar, Indonesia

e-mail: ^{*1} nurhayati.djabir@atim.ac.id

Abstract

Garbage is one of the causes of environmental pollution. In waste disposal, people usually combine metal and non-metal waste in one place so that the quality of environmental health decreases. This study aims to create a portable smart trash can with Metal & Non Metal separator. This research is an experimental research conducted through two stages, namely the design stage and the testing stage. This system consists of metal detector, ultrasonic sensor, IR proximity sensor, Inductive Proximity Sensor and servo motor. The test results are that the lid will automatically open because it is driven by a servo motor if the ultrasonic sensor detects the presence of a maximum human within 72 cm. If the metal and non-metal trash bins are full the lid will not open and the buzzer will sound. Furthermore, when inserting trash, if the inductive proximity sensor and capacitive proximity sensor is worth 1 then what is detected is metal trash and the servo will rotate and direct the trash to the metal bin. Likewise, if only the capacitive proximity sensor has a value of 1 and the inductive proximity sensor detects a metal value of 0, the servo will rotate and direct the garbage to the non-metal trash can.

Keywords—Arduino, detector, ir proximity, sensor

INTRODUCTION

Advances in science and technology motivate people to be able to overcome various problems that arise in everyday life. For example, humans want everything to always look clean, one of which is the cleanliness of the environment from garbage. Garbage is a residual material produced from human activities. As there is still a lot of garbage scattered in the surrounding environment, this is due to the low awareness of the community regarding improper waste disposal.

With the development of microcontroller and sensor technology, various tools have emerged to increase public awareness of the importance of keeping the environment clean from two types of waste, namely metal and non-metal waste. So far, most of the trash cans found in everyday life only place one trash can that is mixed between metal and non-metal. Examples are copper from cables and iron bolts which are included in the metal waste group, as well as paper, plastic bottles and rubber which are included in the non-metallic waste group.

People have been disposing of garbage not according to its type, so people only throw garbage in one place, which can result in the mixing of metal and non-metal waste in one trash can. Which will have an impact on decreasing the quality of the environment and resulting in an environment that is not beautiful to look at [1,2].

This research was previously carried out with the title Prototype of automatic metal and non-metal detector trash bins [3], and the other research [4] with the title "Designing a Smart Trash Can Using an Arduino Microcontroller-Based Proximity Sensor". In previous research [3], there are things that need to be developed, namely that the tool does not contain Automatically close the open trash can and an indicator if the trash can is full.

This study develops the automation system in the trash. This research makes automatic trash cans with portable metal and non-metal separators, which utilize ultrasonic sensors to open

the garbage cover, capacitive and inductive proximity sensors to sort the type of garbage and servo motors for driving and infrared sensors to detect trash bins when they are full.

RESEARCH METHOD

The design and manufacture of this research was carried out from June 2022 to August 2022 at the ATI Makassar Polytechnic Laboratory, in Sunu Street at ATI Polytechnic Campus Makassar, South Sulawesi. This type of research is experimental research by designing and making automatic trash cans that can sort out metal and non-metal waste based on a microcontroller. The stages of data collection in this study were carried out in several stages as follows: (1) the Observation and Literature Study Stage, is an early stage where the author conducts a direct observation survey to the surrounding environment to support the author's understanding of the working principle of the desired tool. (2) hardware design stage (hardware), hardware design carried out by researchers, namely the design of making the body of the trash can, added a box and several sensors, namely proximity ultrasonic and infrared, and modified the trash can by adding a servo motor, LCD, and several other components to make the trash can work automatically.

a) Mechanical, in carrying out this design, the following are carried out:

1. Image design

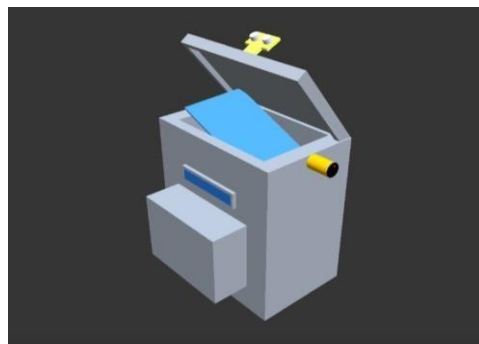

Figure 1 Trash can body design

2. Material measurement and cutting
3. Material assembly and positioning
4. Tool design

b) Software design

In starting this design, what was done were: creating program listings; checking or compiling the program, transferring the program to the microcontroller system; Block Diagram

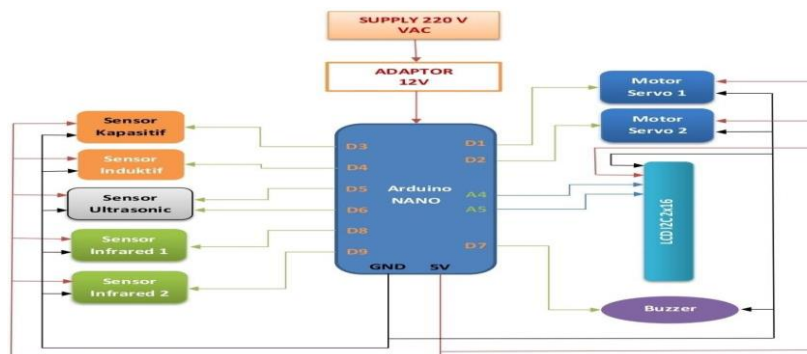

Figure 2 System block diagram

Note : The block diagram above is a series of automatic trash cans with metal and non-metal separators with a supply coming from 220 VAC and the voltage is lowered and converted to DC using an adapter to 12 VDC then lowered again using a stepdown module to 6 VDC and then connected to the system circuit. Proximity, inductive, infrared and ultrasonic sensors as input and servo1, servo2, LCD I2C 16x2 and buzzer as output.

Data analysis

In this study, the steps for system testing and data collection were carried out as follows; (1) data retrieval to determine the distance sensor detects objects to open the trash can cover, (2) data collection to determine the accuracy of the sensor reading the sorting of metal and non-metallic waste types, (3) data collection to find out how the sensor detects if the garbage is full, (4) analyze whether the servo works according to sensor readings.

RESULTS AND DISCUSSION

Wiring Diagram

Picture of the wiring diagram created on the Fritzing application uses a charging adapter supply with an output voltage of 5V to activate the microcontroller, proximity sensor, infrared sensor, servo and 16x2 I2C LCD. Arduino NANO as system control center.

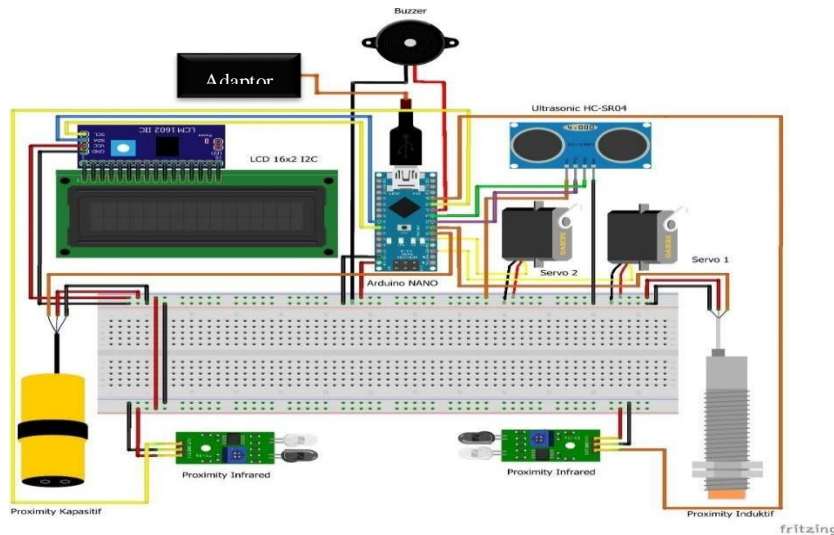

Figure 3 Wiring diagram

Testing the opening and closing of the trash can

This test is carried out to find out at what distance this tool detects humans so that the lid of the trash can opens automatically and what if the metal or non-metal garbage collection is full. The following table shows the test results for opening and closing the trash can.

Table 1 Measurement data for object reading distance and opening and closing the trash can

No	Human Distance (cm)	Ultrasonic detect	Infrared Detected Full of Trash		Buzzer	Servo1	Condition of trash can lid
			Metal	Nonmetal			
1	80 cm	No	No	No	Silent	Off	Closed
2	72 cm	Yes	No	No	Silent	On	Opened
3	70 cm	Yes	No	No	Silent	On	Opened
4	60 cm	Yes	Yes	No	Ring	Off	Closed
5	50 cm	Yes	No	No	Silent	On	Opened
6	40 cm	Yes	No	Yes	Ring	Off	Closed
7	30 cm	Yes	No	No	Silent	On	Opened
8	20 cm	Yes	No	No	Silent	On	Opened
9	15 cm	Yes	No	No	Silent	On	Opened

10	10 cm	Yes	No	No	Silent	On	Opened
11	5 cm	Yes	Yes	Yes	Ring	Off	Closed

In table 1 above, object distance measurements are made from 80 cm to 5 cm. Based on the measurement data, it can be seen that this tool is set at a distance of 70 cm but the sensor still reads a maximum at a distance of 72 cm and after the ultrasonic sensor detects the object, servo1 will move and open the lid of the trash can.

It can also be seen in the 4th, 6th and 11th experiments if the infrared sensor detects metal, non-metallic or both waste is full, then servo1 to open the trash can cover will not move and the buzzer will sound so that the trash can cover does not open. To reuse it, the trash can must be emptied first.

Testing tools for sorting metal and non-metal waste

This test is conducted to determine the type of waste detected by inductive and capacitive proximity sensors. After several tests, the results obtained in the following table.

Table 2 Test data for sorting metal and non-metal waste

No	Experimental Types	Type of Garbage		Proximity Inductive	Proximity Capacitive	Servo2	Note.
		Metal	Nonmetal				
1	Garbage 1		Yes	Undetected	Detected	Move from 90° to 160°	Suitable
2	Garbage 2	Yes		Detected	Detected	Move from 90° to 20°	Suitable
3	Garbage 3		Yes	Undetected	Detected	Move from 90° to 160°	Suitable
4	Garbage 4	Yes		Detected	Detected	Move from 90° to 20°	Suitable
5	Garbage 5		Yes	Undetected	Detected	Move from 90° to 160°	Suitable
6	Garbage 6	Yes		Undetected	Detected	Move from 90° to 160°	Not Suitable
7	Garbage 7		Yes	Undetected	Detected	Move from 90° to 160°	Suitable
8	Garbage 8	Yes		Detected	Detected	Move from 90° to 20°	Suitable
9	Garbage 9		Yes	Undetected	Detected	Move from 90° to 160°	Suitable
10	Garbage 10	Yes		Detected	Detected	Move from 90° to 20°	Suitable

In table 2 above, an experiment is carried out to include some metal and non-metallic waste, when entering non-metallic waste, the capacitive proximity sensor will detect garbage objects and the inductive proximity sensor will not detect any metal so that the servo2 will rotate from 90° to 160° directing the garbage to the shelter. non metal. On the other hand, if you insert metal trash, the inductive and capacitive proximity sensors both detect trash and metal objects so that the servo2 will rotate from 90° to 20° directing the garbage to the metal shelter.

It can also be seen that there was an error in the 6th experiment, namely the waste that was entered was metal waste, but the capacitive sensor first detected the waste because the inductive sensor only detected metal at a maximum distance of 4 mm, so the waste sorting was not appropriate.

CONCLUSION

From the test results, the trash can cover will open automatically and be driven by servo1 if the tool in this study detects objects at a maximum distance of 72 cm, but if the infrared sensor detects the metal, non-metal or both trash bins are full, then the trash can cover can't be opened and the buzzer will sound. Furthermore, the waste that is entered will be sorted according to its type, if metal is detected, the

servo2 will rotate from 90° to 20° which directs the garbage to the metal bin. If non-metal is detected, the servo2 will rotate from 90° to 160° which directs the garbage to the non-metallic place.

REFERENCES

- [1] Aritonang, Prengky L. E., Bayu E. C., Daniel S., & Prasetyo J. 2017. *Rancang Bangun Alat Pemilah Sampah Cerdas Otomatis the Prototype of Automatic Smart Trash Clustering Tool*. Snit, Balikpapan.
- [2] Dadang Haryanto, Wijaya R.I. 2019. *Tempat Sampah Membuka Dan Menutup Otomatis Menggunakan Sensor Inframerah Berbasis Arduino Uno*. Jumantaka, Tasikmalaya.
- [3] Fatmawati K., Sabna E., & Irawan Y. 2020. Rancang Bangun Tempat Sampah Pintar Menggunakan Sensor Jarak Berbasis Mikrokontroler Arduino. *Journal of Computer Science, Pekanbaru*.
- [4] Harmaji L., & Khairullah L. 2019. Rancang Bangun Tempat Pemilah Sampah Logam dan non logam otomatis berbasis mikrokontroler. *Progresif: Jurnal Ilmiah Komputer, Banjarbaru*