



Analysis Of The Supply Chain Of Cayenne Pepper In South Sulawesi

AUTHORS INFO

Sri Hardianti Rosadi
Puangrimaggalatung University
srihardiantirosadi64@gmail.com
+6281354870001

Fitry Purnamasari
Puangrimaggalatung University
fitry.purnamasarifp@gmail.com
+6285242071633

Hasnah
Food Crops, Horticulture and Animal
Husbandry Department, Mamuju Regency
hasnahmahmud92@gmail.com
+6285255436797

ARTICLE INFO

ISSN: 2548-2211
Vol. 4, No. 1, June 2021
URL: <https://usnsj.com/index.php/AJ/article/view/1535>

© 2021 AJ All rights reserved

Abstract

This study aims analyzing supply chain maps and activities in the cayenne pepper in South Sulawesi. This research was conducted in Enrekang Regency with the number of respondents as many as 5 farmers and traders. This study uses the is qualitative research with naturalistic research methods which are natural research. The results showed that Supply chain mechanism for cayenne pepper in South Sulawesi, starting from the flow of products from farmers, village collectors, wholesalers, inter-island traders to retailers. The flow of information on the supply chain of cayenne pepper is well integrated between actors in the supply chain, while the flow of money occurs in accordance with the agreement of actors in the supply chain. And Supply chain activities consist of two actors in the supply chain, namely the main and supporting actors. The main actors consist of farmers, village collectors, wholesalers, inter-city traders and retailers. Meanwhile, the supporting actors consist of agricultural extension agents, farmer groups, the Agriculture Service, Agribusiness Sub-Terminal, farmer shops, farm laborers, inter-island traders, and consumers.

Keywords: Cayenne Pepper, Supply Chain, Farmers, Traders, Consumen

A. Introduction

Cayenne pepper is a horticultural commodity that is widely used by the community, where its use as a kitchen spice and daily processed ingredients is an indication that cayenne pepper has a wider market opportunity. The market opportunity for cayenne pepper is not only focused on fulfilling the demand for household consumption and domestic industry, but cayenne pepper is also an export target seeing that the level of production is increasing every year. The level of cayenne pepper production from 2013 to 2019 shows an increase

which tends to increase with an average increase of 0.14% per year (Ministry of Agriculture, 2021). This is in line with the need and consumption of cayenne pepper from 2017 to 2018 which increased from 629,344 tons to 647,767 tonnes / day (Center for Agricultural Data and Information Systems, Secretary General of the Ministry of Agriculture, 2018).

One of the areas outside the island of Java that produces cayenne pepper is South Sulawesi with a production of 261,147 tons with a production contribution of 19% of the total production of cayenne pepper in Indonesia, which is 1,374,215 tons / year.2019, after the regions of East Java, West Nusa Tenggara, Central Java and West Java (Ministry of Agriculture, 2021). The prospect of developing cayenne pepper is very wide open. However, cayenne pepper is inseparable from the problem of price fluctuations that occur in each region, including in South Sulawesi.

The development of average prices at the consumer level in South Sulawesi can be seen in Figure 1.

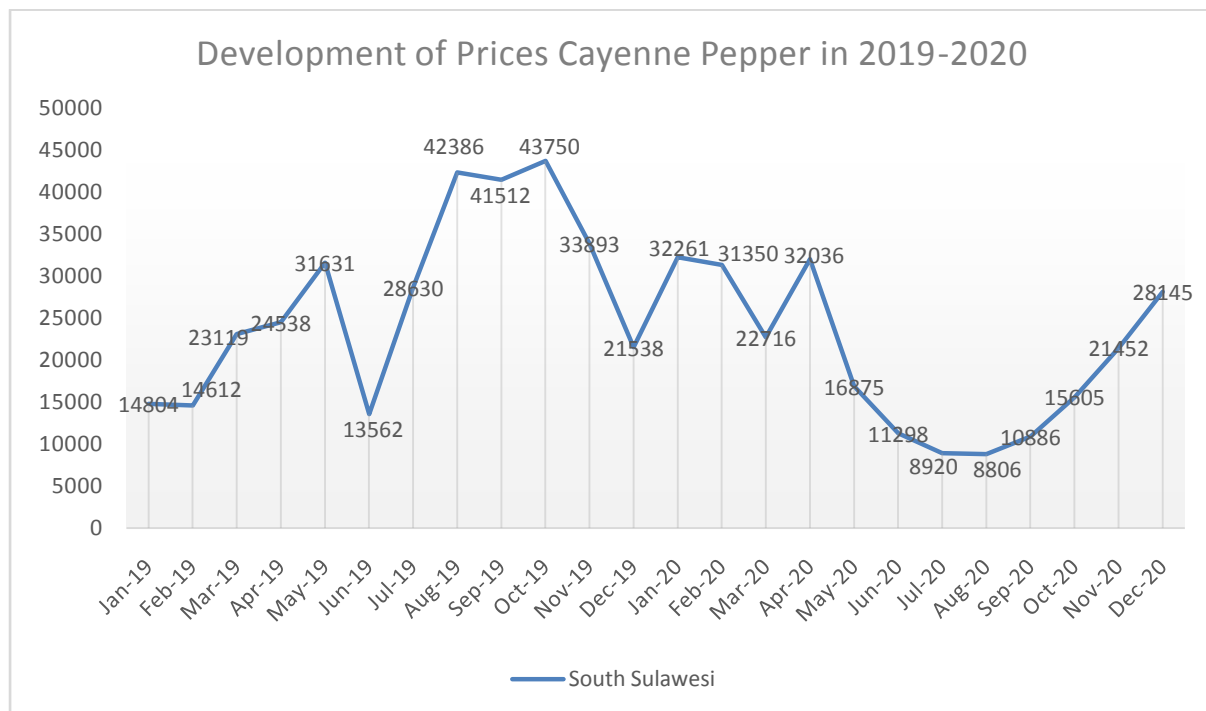

Source: Ministry of Agriculture, 2021.

Figure 1. Development of Prices Cayenne Pepper 2019-2020

From the graph of the trend of cayenne pepper price developments from 2019 to 2020 above, price fluctuations occurred, where in June 2019 there was a significant increase in prices, increasing until October 2019 then experiencing a price decline and reaching the lowest price in August 2020. This indicates that there is price fluctuation in South Sulawesi. Price fluctuations can occur due to the influence of prices prevailing in the market and people's purchasing power. Where the price of a commodity is strongly influenced by the costs that must be incurred (Yuliahwati, et al, 2019). Price fluctuations can also occur due to inefficient management in the supply chain (Josine, NA, et al, 2018). Supply chain management efficiency can be achieved if all parties involved, cooperatively supervise and manage distribution channel relationships (Saputro, N. Y & E. Sedyono, 2019). Where the involvement in each actor of the supply chain of cayenne pepper is very long, so that to get to consumers of cayenne pepper products must pass through several distribution channels. This is supported by the results of research conducted by Siahaan(2018) which is located at the Bersehati market in Manado location where the distribution channel is the longest starting from retailers, wholesalers, collectors to farmers. The long distribution of the supply chain is also supported by the nature of agricultural products that are perishable and perishable and the unpredictable availability of chilies, where availability will be abundant in the dry season or transition season because chilies do not require much water (Center for Agricultural Data and Information Systems, 2018). So that it is a factor that causes high price fluctuations in South Sulawesi.

So that we need a mechanism that regulates the availability of products to consumers. Where the mechanism formed in the supply chain is expected to be able to make agricultural products more efficient and effective to reach consumers. The supply chain is one approach that can be used to solve the problems that exist in the commodity of cayenne pepper, ranging from unpredictable supply of cayenne, price fluctuations, production uncertainty, extreme weather, long distribution channels, transportation and price stability (Indriani, R et al. 2019). The supply chain concept is an integrated concept and is an integrated marketing system that includes the integration of products and actors in order to provide satisfaction to customers (Marimin & N. Maghfiroh, 2010).

The level of cayenne pepper production in South Sulawesi can be seen in Figure 2:

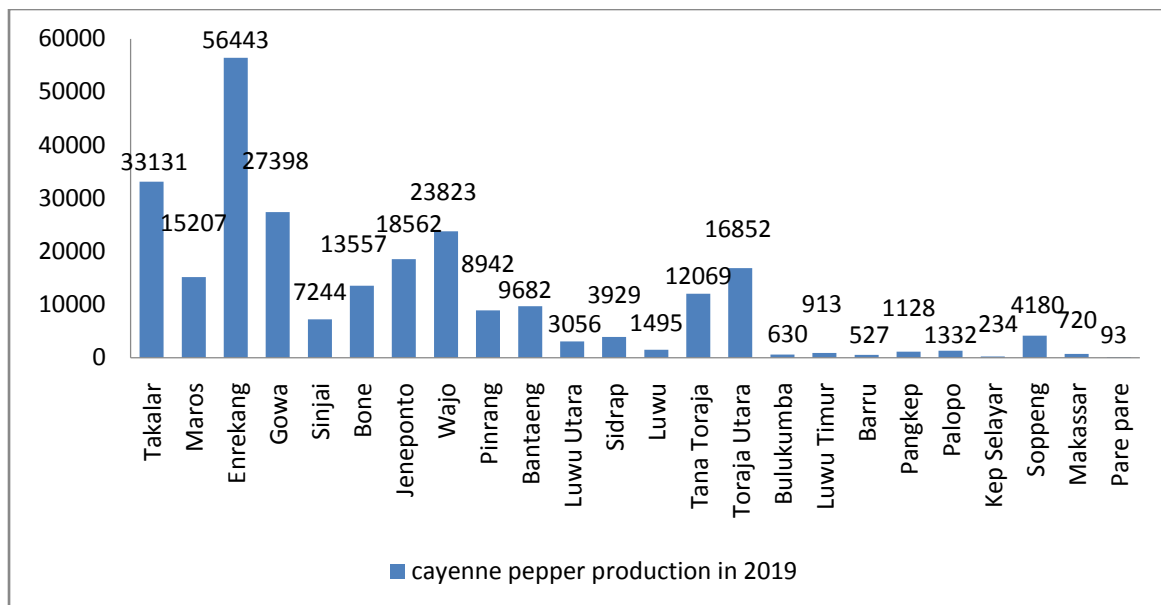

Source: BPS South Sulawesi, 2020

Based on Figure 2 shows that the highest production level of cayenne pepper in South Sulawesi is in Enrekang Regency with a production level of 56,443 tons / year, followed by Takalar Regency and Gowa Regency with the second and third highest production levels with a production of 33.131 tons / year and 27.398 tons / year. Meanwhile, the lowest cayenne production was in the city of Pare-pare with a production level of 93 tons / year. By looking at the level of cayenne pepper production in South Sulawesi, and the economic problems that trigger an increase in cayenne prices due to the long distribution chain. So we need a description of the mechanisms and activities of each actor in the supply chain for the Cayenne Pepper commodity in South Sulawesi.

B. Methodology

This type of research is qualitative research with naturalistic research methods which are natural research, what it is in normal situations that are not manipulated by circumstances and conditions, where the results of this study emphasize more on meaning than generalization (Nurdin and Sri, 2019).

This research was conducted in Enrekang Regency, South Sulawesi Province. The selection of this location was made on purpose (purposive) with the consideration that Enrekang Regency is the largest producer of cayenne pepper in South Sulawesi, 2019. This study uses informants as "key information" starting from selected farmers purposive sampling. The first informant is believed to be able to "open the door" to the researcher to enter the research object. The number of informants is 6 people with the criteria as chairman / member of the farmer group who are considered successful in cayenne pepper farming. Further research informants were determined in a way snowball sampling from farmers as initial monitoring points to consumers. Technique snowball sampling just like a snowball rolling in determining the research subject (Suwardi, 2006).

The data used in this research are primary and secondary data. Primary data were obtained from farmers, collectors, wholesalers, retailers and inter-island traders. Meanwhile, secondary

data were obtained from the Agriculture Office of Enrekang Regency, Central Bureau of Statistics of South Sulawesi.

Results and Discussion

Supply Chain Mechanism

The supply chain mechanism involves three main streams, namely the flow of products, the flow of information and the flow of money. In general, the supply chain structure of Cayenne Pepper in Enrekang regency involves several actors. For more details cayenne pepper on the supply chain in Enrekang Regency is presented in Figure 3.

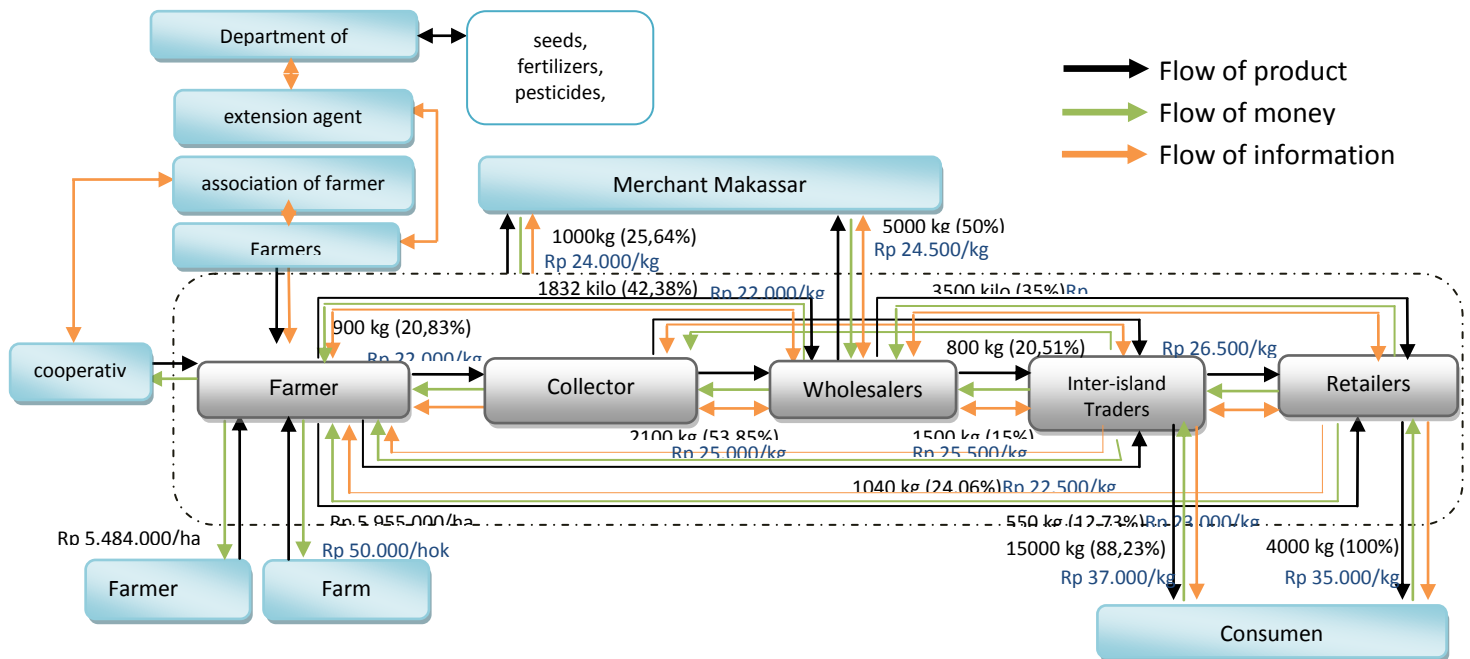

Based on Figure 3, it shows that the flow of goods, information and money flow can be explained below:

a. Flow of product

The flow of product in the supply chain involves the entire flow of products starting from farmers as producers to consumers. Informants, amounting to five people, produced cayenne pepper as much as 4925 kg (100%). This cayenne pepper is then sold to village collectors as much as 2000 kg (40.61%), wholesalers 2700 kg (54.82%) and retailers as much as 225 kg (4.57%). This shows that the selling products of farmers are dominated by village collectors and wholesalers, where the farmers and village traders and wholesalers have established strong cooperative ties. Although in writing, the farmer and the trader do not have a cooperation contract in the form of capital assistance or production facilities, the partnership formed is only in the form of farmers often selling their crops to these traders, so that emotional ties have been established even before the agribusiness sub terminal was established. In addition, the production that is not too large makes farmers sell their crops directly to village collectors and wholesalers. In accordance with the results of research conducted by Saptana, et al. (2018) which states that generally farmers sell their crops to village collectors, where this can happen because farmers cultivate chilies on a business scale and a relatively limited amount of production.

In addition, with the existence of the Agribusiness Sub Terminal, farmers prefer to sell their crops to wholesalers in the Agribusiness Sub-Terminal on the grounds of convenience and ease of transactions and higher prices than when selling them to village collectors. This agribusiness sub terminal will make transactions easier for farmers, because the selling price from farmers will be paid directly by the traders. The flow of product from farmers to retailers is only Rp4.57%. This shows that there is no relationship between farmers and retailer a strong cooperative relationship, so that farmers do not have the obligation to sell

their crops to retailers. On the other hand, farmers have the opportunity to sell their crops to the traders they want.

The total sales of cayenne pepper from village collectors to wholesalers were as much as 4000 kg (44.44%), to inter-city traders as much as 4500 kg (50%) and to inter-regional traders as much as 500 kg (5.55%). This shows that the largest sales of village collectors are found in inter-city traders. Where between village traders and inter-city traders, there is a strong cooperative relationship. Inter-city traders facilitate access to transportation of goods, so village collectors no longer need to deliver cayenne pepper to an area or place. Inter-city traders who will immediately bring a pick-up car to pick up the bird's eye chilies, after the agreement is made.

Total sales of cayenne pepper wholesalers to inter-city traders were 9000 kg (40.91%), to inter-regional traders as much as 10000 (45.45%) and to retailers as much as 3000 kg (13.64). This shows that the biggest sales of wholesalers are found in inter-regional traders, amounting to 45.45%. Where the relationship between wholesalers and traders between regions is only established trade relations. Wholesalers only sell to traders who have a higher bargaining value. So that if it is suitable, the trader will immediately sell it, regardless of who the wholesaler is selling it with.

The total sales of cayenne pepper from inter-city traders to inter-regional traders is 12000 kg (29.42%), to inter-island traders as much as 21000 kg (61.76%) and to retailers as much as 3000 kg (8.83%). The biggest sales of inter-city traders are to inter-island traders. This shows that between inter-city traders and inter-island traders there is a strong cooperative relationship, where inter-city traders will sell to inter-island traders they know. The total sales of cayenne pepper retailers to consumers is 3300 kg (100%). This shows that retailers 100% sell their harvests to consumers who come to the market.

b. Flow of Information

The flow of information that occurs in the supply chain of cayenne pepper in Enrekang Regency is very good. Where communication between farmers and traders has taken advantage of technology via telephone, so that in transacting traders can directly contact farmers or other traders.

Information between farmers and village collectors and wholesalers is the quantity of cayenne pepper that is ready to be sold by farmers. Price negotiations took place at that time, if the price was accepted, the farmers would immediately bring their cayenne pepper to the traders. Furthermore, if village collectors or wholesalers need cayenne pepper that has been ordered directly by inter-city traders in the market, the collecting traders will contact the farmers via telephone or go directly to the farmer's place. The flow of information that exists between farmers and traders is a vertical flow of information. In accordance with the results of research conducted by Indriani. R.

Information from village traders and wholesalers to inter-city traders in the form of fulfilling requests from inter-city traders. If the request is fulfilled, the collector traders will directly contact the inter-city merchant to discuss the delivery of the cayenne pepper. If the inter-city traders who directly carry the cayenne pepper use a pick-up car or truck, the price given by the trader is also not too high. Conversely, if the inter-city traders do not provide a means of transportation, the intermediate traders and wholesalers will increase their prices. Negotiations regarding prices also depend on agreements between collectors and wholesalers regarding the distribution of cayenne pepper.

In addition, information that occurs in the supply chain of Cayenne Pepper is also in the form of exchange of information between farmers regarding prices and the success of each of their harvests. Price information will have an impact on farmers' attitudes in negotiating with traders. Like when the price of cayenne pepper rises, farmers are reluctant to call traders. They want the traders themselves to come down directly or make phone calls to negotiate with the farmers. It is different when prices fall and production is abundant, then farmers who will call the traders directly to sell their crops, to avoid even more losses.

Likewise, information on yields is very important among farmers in terms of obtaining good seeds for their cultivation. Because one farmer with another farmer has a tendency to follow what other farmers are doing so that it can be successful. As in the case of imitating what seeds are suitable for planting in their location. Because not all the seeds they use are the same. So when there are other farmers who use different seeds from the farmer and are considered successful, then to sow their own seeds for the next planting period, the seeds are used by the farmers. The information exchange that exists between farmers is called a horizontal information flow. Where the horizontal flow of information only occurs at the level of cayenne pepper farmers, where the flow of information is in the form of sharing or exchange opinions on cultivation techniques, planting techniques and selecting superior seeds that can increase production yields (Indriani.R, et al, 2019).

c. Flow of Money

The money flow that occurs in the supply chain of cayenne pepper in Enrekang Regency starts with the consumer as the buyer and then flows through each link and reaches the producer. The cash flow started from farmers buying production facilities in the form of seeds, polybags, plastic mulch, compost, liquid organic fertilizer, agricultural lime, rainbow NPK fertilizer, and pesticides at a cost of Rp 3,543,000 / ha. The use of labor services in the cultivation of cayenne pepper uses labor of Rp 50,000 / hok in the form of labor in seeding, nursery maintenance, seeding, mulching, stakes, planting, embroidery, peeling, basic fertilization, supplementary fertilization, spraying, stringing, harvesting at a cost the amount spent is Rp 7,146,000 / ha. Selling price Cayenne pepper from the farmer to traders collector village Rp. 22,000 / kg and to wholesalers Rp 24,000 / kg, as well as to retailers of Rp 23,000 / kg. Farmers sell their cayenne pepper to big traders because farmers have to pay for transportation to get to the market, while retailers are lower than wholesalers, because retailers come directly to farmers, as well as village collectors.

Village collectors sell cayenne pepper to wholesalers and traders city with price Rp 25,000/ kg, and Rp 27,000 to traders between regions. The selling price of cayenne pepper in inter-regional traders is higher than that of large traders and inter-city traders because there is no cooperative relationship that exists between traders, so that in negotiating the price, the relationship seen by village traders is only trade relations.

Wholesalers sell to inter-city traders, retailers and inter-regional traders at a price of Rp 27,000 per kg. The selling price formed between traders is the same. This is because the system in the market is still heavily influenced by the prices prevailing in the market. So that traders do not necessarily raise or lower prices.

Then inter-city traders sell cayenne pepper to retailers at a price of Rp. 27,000/kg, to inter-regional traders at Rp. 30,000/kg and to inter-island traders at Rp. 32,000/ kg. Prices for each trader are different, due to the calculation of freight and transportation costs borne by traders between cities. Inter-city traders pay for transportation to the port of pare-pare. So that the cost of cayenne pepper to inter-island traders is higher than the cost of cayenne pepper to retailers and traders between regions. However, the prices formed in this supply chain are always based on an agreement and take into account freight and transportation costs.

Retailers sell cayenne pepper directly to consumers, at a price of Rp 37,000/kg. Retailers sell at a price of Rp 37,000/kg due to the many risks the retailer must bear. To get to consumers, the purchased cayenne pepper will be re-sorted and separated which ones are suitable for sale or not. Because the cayenne pepper in the market can be sold by traders up to one week later. So that the risk of rot is always there.

Activities of Actors in the cayenne pepper Supply Chain in Enrekang Regency

There are two actors in the supply chain, namely the main actors and the supporters. The main actors consist of farmers, village collectors, wholesalers, inter-city traders and retailers. The activities of each of the main actors are described in Table 1.

Table 1. Activities of the main actors in the chain supply of Cayenne Pepper in Enrekang Regency, 2020.

No	The Culprit Main	Activity
	Farmer	<ul style="list-style-type: none"> • Provision of production facilities. • Land preparation • Seeding • Maintenance of seeds • Surgical • Impulse • Stake installation • Planting • Stitching • Forging • Fertilization • Spraying • Harvest • Selling crops to traders Purchasing
	Traders	<ul style="list-style-type: none"> • cayenne pepper from farmers • Selling cayenne pepper to wholesalers, inter-city traders and inter regional trades
	Traders big	<ul style="list-style-type: none"> • Buying cayenne pepper from farmers or village collectors Sell cayenne peppers to inter-city traders, retailers and inter-regional traders • Sorting • Packaging • Transport • Weighing
	Inter City Traders	<ul style="list-style-type: none"> • Buying cayenne pepper from village traders and wholesalers • Selling cayenne pepper to retailers, inter-regional traders and inter-island traders • Weighing
	Retailer	<ul style="list-style-type: none"> • Buying cayenne pepper from farmers, wholesalers, and inter-city traders in relatively small quantities to be resold to consumers • Sorting • Weighing

a. Farmer

Activities that occur in the supply chain of Cayenne Pepper in Enrekang Regency are started from farmers as producers who obtain cayenne pepper seeds from traders or farmer shops in the area. However, there are also farmers who do their own seed nurseries. They consider the harvest yields of cayenne pepper which they consider successful to save for their own use as their own seeds by observing the quality of the seeds that farmers produce. For production facilities such as fertilizers and pesticides, farmers get it from collectors and farmer shops which also function as a place for farmers to sell their cayenne pepper. Some village collectors become a place for farmers to sell their produce. When harvesting, farmers immediately go to the village's merchant gathering place. Enrekang Regency, which is located in Alla District or directly sells it to inter-city traders. The management policy of the Agribusiness Sub Terminal in marketing is to help market agricultural products so that farmers get a fair price and do not suffer losses due to damage to their agricultural products. Marketing assistance provided by the Agribusiness Sub Terminal is in the form of regulation and planning of sales volume and product delivery to consumers, both local and overseas markets.

Farmers are the main actors in the cayenne pepper supply chain. Activities carried out by farmers start with the provision of production facilities. The production facilities needed by

farmers are seeds, fertilizers, pesticides, agricultural tools and machinery, mulch, lime. This means of production can be obtained by farmers from farmer groups in the form of assistance from the local government. Apart from being in the form of assistance, farmers who do not get assistance obtain production facilities from farmer shops or from collectors.

Apart from providing production facilities, farmers also carry out several activities such as land processing, which is carried out using agricultural tools and machinery. Cultivation of the land uses hoes and agricultural machines in the form of cultivators, which farmers borrow from farmer groups. After cultivating the land, the farmers seed their own seeds. This seeding is done in polybag bags. After the seeds grow to a size of 4-5 cm, the seeds are ready to be transferred to the land. After the seeding is done, it is very necessary to carry out maintenance so that the seeds stay alive, while doing the cutting on the farmer's land. To protect the land from being too dry, mulching is carried out and installed along the land that has been shaded. After that, a bamboo stake is installed. When ready to be moved and the land is ready, then planting. For maintenance, it is done embroidery, and peeling until fertilizing and spraying. After 90-100 days, harvesting is carried out and the cayenne pepper is ready to be sold to traders.

b. Village gathering traders

The activity of village collectors is to buy cayenne pepper from farmers and sell it directly to wholesalers, inter-city traders and retailers. Before making a transaction, first the cayenne pepper is weighed by the village collector, after that, the cayenne pepper will be paid according to the agreement between the farmer and the trader. However, there are also collector traders who collect cayenne pepper when called directly by the wholesaler with the volume and price determined directly by the agreement of both parties. If the demand cannot be fulfilled or is still less than the volume you want to buy, the collector will call other farmers to fulfill the volume of demand.

c. Wholesalers

The activities of large traders started with traders who bought cayenne pepper from farmers and village collectors. Big traders who buy cayenne pepper from farmers are just waiting for the farmers to come to bring their cayenne pepper to the market. This shows that wholesalers do not incur any more transportation costs to buy cayenne pepper. Another case, if the wholesaler will sell the cayenne pepper to traders between cities. Then the big traders will incur freight and transportation costs. In addition, before buying crops from farmers and traders village collectors, the wholesaler will weigh the harvest before paying the cayenne pepper from the farmer.

Wholesalers at the Agribusiness Sub Terminal receive goods in the form of Cayenne Pepper from several Districts in Enrekang Regency, such as Masalle District, Anggeraja District, Baroko District and Alla District.

After weighing, the cayenne pepper is sorted which will be sold to inter-city traders. For cayenne pepper to be sent outside the island such as Kalimantan, the traders will do the packaging in the form of putting it in a wooden crate. These wooden crates can contain up to 40 kilograms of cayenne pepper. Meanwhile, for inter-regional shipments, such as Makassar, wholesalers only carry out packaging in the form of plastic bags.

d. Inter-city traders

The activities of inter-city traders began with inter-city traders who bought large quantities of cayenne pepper from collectors. The cayenne pepper will be sold directly to inter-island traders as well as inter-regional traders and retailers. Cayenne pepper that will be sent out of the region will be recalculated by traders from outside the region who enter to buy cayenne pepper. Likewise, before making a purchase transaction, inter-city traders will weigh cayenne pepper. Cayenne pepper which will be sold outside the island will be packaged according to the agreement between the traders. There are inter-island traders who want packaging from styrofoam, some are in the form of wooden crates. Inter-city traders will bear the cost of transportation to the port of Pare-Pare. Furthermore, shipping costs will be borne by the inter-island merchant. For retailers, packaging is only in the form

of a plastic bag. Because the volume of purchases is not too large and the distance is not too far.

Furthermore, inter-city traders send product to other islands such as East Kalimantan, North Sulawesi, Central Sulawesi, West Sulawesi and Southeast Sulawesi through the port of Pare-pare using transportation assistance provided by the Agribusiness Sub-Terminal. Before being sent outside the island of Cabai Rawit, the traders in the Agribusiness Sub-Terminal are re-sorted. Meanwhile, cayenne pepper that is sent outside the Enrekang area such as Makassar, Pinrang, and Luwu is not sorted first.

e. Retailer

The activities of retailers in the supply chain of cayenne pepper in Enrekang Regency begin with the purchase of cayenne pepper from wholesalers and inter-city traders. Then sold directly to consumers. Retailers in selling cayenne pepper will weigh per kilogram for their consumers. Also, to avoid the risk of spoilage, traders should not buy too large a volume.

Furthermore, the supporting actors consist of agricultural extension agents, farmer groups, the Department of Agriculture, the Agribusiness Sub-Terminal, farmer shops, farm laborers, inter-island traders, and consumers.

The activities of each of these actors are described in Table 2.

Table 2. Activities of actors supporting the supply chain of Cayenne Pepper in Enrekang Regency, 2020.

No	The Culprit	Activity
1.	Departement of Agriculture	Providing production facilities in the form of seeds, fertilizers, pesticides, mulch and polybags to farmer groups with the assistance of extension workers
2.	Agriculture Extension	Provides information about the preparation of RDKK to farmers as well as innovations and agriculture technology in the cultivation of cayenne pepper
3.	Farmers	Become a forum for farmers to exchange information about cultivation and market conditions as farmer well as the distribution of subsidized input production assistance needed in the process of cultivating cayenne pepper.
4.	Sub Terminal Agribusiness	Facilitating the marketing of agricultural products carry out market levies provide price information services
5.	Farmer's shop	Providing inputs needed by farmers in Cayenne pepper farming.
6.	Farm workers	Providing services to farmers in the process of cultivating cayenne pepper until harvest.
7.	Traders	Buy cayenne pepper from village collectors, wholesalers and intercity traders.
8.	Inter Regional Traders	Selling cayenne pepper to consumers outside the region or to traders outside the region
9.	Inter Island Traders	Traders in Kalimantan and Kendari Island who buy cayenne pepper from inter-city traders in Enrekang Regency.
10.	Consumer	Individuals who buy Cayenne pepper from retailers.

The activities of supply chain actors include:

a. Department of Agriculture

The activity of the Department of Agriculture is to provide assistance to farmer groups proposing RDKK which is facilitated by agricultural extension agents. This assistance is in the form of seeds, fertilizers, pesticides, mulch, and polybags.

b. Agricultural Extension

The agricultural extension's activity is to provide information about the preparation of RDKK to farmers. This RDKK submission is intended so that farmer groups receive assistance from the government in the form of production facilities, such as seeds,

fertilizers, pesticides, and agricultural machinery. In addition, information regarding the planting schedule will always be discussed by farmers to the extension agents. Before starting planting, the farmer will contact the extension worker and the extension worker will directly see the cayenne pepper cultivation process, whether it is ready for planting or not. Information about innovation and technology is always discussed with farmers to get maximum results.

c. Farmers

The activities of farmer groups in the cayenne pepper supply chain in Enrekang Regency are how farmer groups will become a forum for farmers to exchange information about cultivation, such as when the farmers will plant and seed them. Farmers will always discuss this planting schedule with members of their farmer groups, considering the pests and diseases that will attack when they miscalculate the planting schedule and market conditions as well as the distribution of subsidized production facility assistance needed in the process of cultivating Cayenne Pepper. Before planting, a deliberation or "tudang sipulung" will be held with members of farmer groups and extension workers to determine the planting schedule.

d. Agribusiness Sub Terminal

The activity of the agribusiness sub-terminal is to facilitate the marketing of agricultural products where market collectors sell their cayenne pepper. In addition, this agribusiness sub-terminal will collect a market levy of Rp 40,000 / month / trader for market cleaning costs. Services regarding price information are also provided by the Agribusiness Sub Terminal, so that the selling price will be determined based on the price prevailing in the market.

e. Farmer's Shop

The farm shop's activity is to sell the production facilities needed by farmers in the process of cultivating their cayenne pepper. Assistance from the government is not always available, so farmers will still buy the means of production from the farmer's shop. The production facilities that can be sold are seeds, fertilizers and pesticides.

f. Farm workers

The activity of farm labor is to provide services to farmers in the process of cultivating Cayenne Pepper until harvesting. Farm labor is needed by farmers in terms of land cultivation, maintenance, planting and harvesting. Farm laborers in the cultivation process will be paid Rp. 50,000 / hok, while the wages for transportation workers are Rp. 150,000 / hok.

g. Inter-Regional Traders

The activity of inter-regional traders starts from buying cayenne pepper from village collectors and wholesalers to selling back chili peppers to consumers outside Enrekang Regency. The purchased bird's eye chilies will be brought directly by the merchant using a pick-up car or truck. So that the transportation costs are borne by traders between regions.

h. Inter Island Traders

The activity of inter-island traders starts with the purchase of cayenne pepper from inter-city traders in large quantities, which will then be sent and sold to consumers or traders outside the island of South Sulawesi.

i. Consumer

Consumer activity is to buy cayenne pepper from retailers and consume it.

CONCLUSION

Based on the results of research on the supply chain of cayenne pepper in Enrekang Regency, it can be concluded as follows:

1. Supply chain mechanism for cayenne pepper in South Sulawesi, starting from the flow of products from farmers, village collectors, wholesalers, inter-island traders to retailers. The flow of information on the supply chain of cayenne pepper is well integrated between actors in the supply chain, while the flow of money occurs in accordance with the agreement of actors in the supply chain.
2. Supply chain activities consist of two actors in the supply chain, namely the main and supporting actors. The main actors consist of farmers, village collectors, wholesalers, inter-city traders and retailers. Meanwhile, the supporting actors consist of agricultural extension

agents, farmer groups, the Agriculture Service, Agribusiness Sub-Terminal, farmer shops, farm laborers, inter-island traders, and consumers.

REFERENCES

- BPS South Sulawesi. 2020. South Sulawesi Province in Figures. South Sulawesi Province in Figure 2020. Central Statistics Agency of South Sulawesi Province.
- Indriani, R, R. Darma, Y. Musa, AN. Tenriawaru, Made Viantika. 2019. Chili Rawit Supply Chain Mechanism in Gorontalo Province. "Mechanism Of Chili's Value Chain At Gorontalo Province. Journal of Agricultural Socioeconomics. p-ISSN 0853-8395; e-ISSN 2598-5922. Vol. 15, No.1, February 2019.
- Josine, N. A, LRJ Pangemanan, CBD Pakasi. 2018. Analysis of the Supply Chain of Cayenne Pepper Commodities in the City of Manado. Journal of the Agri-Socio Economic Unsrat, ISSN 1907-4298, Vol. 14 No. 1. January 2018: 207 - 214.
- Ministry of Agriculture of the Republic of Indonesia. 2021. Agricultural Statistics Database. <https://aplikasi2.pertanian.go.id/bdsp/id/indicators>
- Marimin & N. Maghfiroh. 2010. Applications Decision Making Techniques in Supply Chain Management. PT Publisher IPB Press. Bogor.
- Nurdin. Ismail, S. Hartati. 2019. Social Research Methodology. Media Friends of Scholars. ISBN:978-623-90984-3-8.
- Center for Agricultural Data and Information Systems Secretary General of the Ministry of Agriculture. 2018. Food Consumption Bulletin. Volume 9 Number 1. 2018.
- Center for Agricultural Data and Information Systems. 2018. Outlook Chili "Horticulture Subsector Agricultural Commodities". ISSN 1907 - 1507.
- Saptana, C. Muslim, SH Susilowati. 2018. Pasko Chain Management for Chili Commodities in Dry Land Agroecosystems in East Java. Journal: Agricultural Policy Analysis. Vol. 16, No. 1. DOI: <http://dx.doi.org/10.21082/akp.v16n1.2018.19-41>.
- Saputro, N. Y, E. Sedyono. 2019. Analysis Supply Chain Management (SCM) for Red Chili Rawit Commodities in Getasan District, Semarang Regency. National Seminar on Information and Communication Technology. e-ISSN: 2685 - 5615.
- Siahaan. Heryanto, LRJ Pangemanan, AJM Maweikere. 2018. Distribution Channel for Cayenne Pepper Commodity in the Bersehati Market, Manado City. Journal of Agri-SocioEkonomi Unsrat. ISSN 1907 -4298. Vol 14 No 2.
- Suwardi, Endraswara. 2006. Methods, Theory, Cultural Research Techniques: Ideology, Epistemology and Applications. Yogyakarta: Pustaka Widayatama.
- Yuliahwati E. Salampessy, Natelda R. Timisela, Yolanda. MTN Apituley. 2019. Marketing Channels of Cayenne Peppers and Shallots in Ambon City. Vol 7. No. 3.