THE EFFECT OF THE COVID 19 VIRUS AND ONLINE LEARNING ON ENGLISH SUBJECTS IN SENIOR HIGH SCHOOL

By

Susan Rachmawati¹⁾, Upik Djanjar²⁾, Arman Syah Putra³⁾, Nurul Aisyah⁴⁾**^{1,4}Faculty of Economics & Business, Bina Sarana Informatika University, Indonesia****²Faculty of Economics, Muhammadiyah Kupang University, Indonesia****³Faculty of Computer, STMIK Insan Pembangunan, Indonesia****Email: ¹susan.srw@bsi.ac.id, ²udjanjar@gmail.com, ³armansp892@gmail.com, ⁴nurul.nly@bsi.ac.id****Abstract**

The background of this research is to find out the effect of the covid-19 virus and variables related to English subject matter and online learning systems in high schools. With the variables above, can these variables affect the teaching and learning system in senior high school. This study uses quantitative methods which are considered appropriate in this study because by using the survey method and conducting questionnaires to 100 people who were randomly selected by the survey, it can produce valid data and can be used for future research. The problem raised in this study is how to find out the effects of the covid 19 pandemic, even though the effects of the covid 19 pandemic are felt in all fields. This research is only limited to the field of education, especially high school education. and can know the effects of the covid 19 pandemic. this study produces new data that can find out the effects of the covid 19 pandemic on the world of education, especially in high school in English subjects, with the results of this research can produce data that can be used as references and future research.

Keywords : Covid 19 Virus, Online Learning, English Subject, Senior High School**INTRODUCTION**

The spread of the Corona virus can no longer be added because there have been many human victims who died of the coronavirus, therefore humans must be able to take care of themselves and be able to reduce the spread of the corona virus, therefore in various fields, many changes have been made, for example in the economic field. the existence of PPKN and community restrictions to prevent the spread of the corona virus which is so terrible, therefore the government also makes a regulation that can help the community. For example, direct cash assistance is expected to be helped by the community. During this covid-19 pandemic, in the field of education, many are affected due to the corona virus, for example, students and teachers, students cannot learn directly in schools and teachers also cannot teach at schools. Therefore, almost all the first sectors

are affected during the COVID 19 pandemic [1].

The problem raised in this study is how to find out the variables that affect the world of education, especially at the high school level and whether these variables affect a subject, especially English lessons. and subjects in high school [2].

The method used in this study is to use quantitative methods by conducting a survey to 100 people who were chosen randomly with this method, this research will be more focused and can get real data in the field. Therefore, with quantitative methods all data will be processed and analyzed. will generate new data that can find out whether the variable has an effect or not on other variables [3].

This study will find something new data, namely what variables can affect high school and high school subjects with variables that can be known, high school can find

advantages and disadvantages during the current pandemic. Therefore, nowadays we must be able to sort and choose which one is best for students and teachers for the common good [4].

LITERATURE REVIEW

The education system in Indonesia has begun to implement a 9-year learning system. In the era of Soeharto era's leadership, compulsory education was required for all Indonesian children so that there would be no more illiteracy. Therefore, the system is said to be successful because it can reduce illiteracy in Indonesia and is now no longer available. there are more people, especially children who are illiterate. Therefore, this system must be continued not only for 9 years but up to tertiary institutions. With this system, all Indonesian people can experience education from elementary to college [5].

Early 2020 was a very tough year for the whole world, therefore the spread of the covid-19 virus has begun to spread starting from the city of Wuhan, China with the covid-19 virus, the whole world was hit by a very heavy pandemic, all sectors were destroyed because it stopped operating due to covid-19 19 millions of victims have died due to the virus. The world is still feeling what a covid-19 pandemic is, which until now has not been able to find a cure. Therefore, all countries are working hand in hand to find a vaccine that can cure the covid-19 virus in the economic field of the country's economy. Many developing and developed countries were destroyed, especially in Indonesia. Indonesia's economic level fell below 5% in the field of education. The education system became an online system, which was originally a face-to-face system [6].

System that has existed since 1990 because the spread of this system has been very effective because it uses a distance learning system this system is widely used by overseas campuses to give lessons to students in different countries Therefore this system was adopted during a pandemic because this system

considered capable of reducing the massive spread of the COVID-19 virus, therefore this system is used until the normal system will return to human life in this world, the online education system will continue to be carried out until this pandemic can end and life can return to normal and the education system returns to normal face system [7].

Offline or face-to-face learning system weve is a system that was used from the beginning the learning system was created because the face-to-face system is considered a very appropriate system in a learning and teaching medium, therefore this system will continue to exist even though the online system continues in the present system. online or face-to-face learning cannot be done because the spread of the corona virus has taken many victims and can no longer be prevented with this system, it can reduce the number of victims of the corona virus [4].

RESEARCH METHOD

Based on the picture of the research method below, there are variables covid 19 virus (X1) and online learning (X2) and the dependent variable is Senior High School (Y) there are three hypotheses, namely the first hypothesis Is there a relationship between coronavirus and Senior High School and hypothesis 2 Is there a relationship online learning to juniors high school hypothesis 3 is a combination of covit-19 and online learning on English subjects at Senior High School. With this hypothesis, it can be seen whether there is a relationship between one variable and another and whether the relationship is significant. Therefore, based on the data, it will be processed so that it will produce data that can find out the results of processing the data.

This study uses a survey stone tool that was carried out to 100 parents of students, in order to find out what subjects had an effect on the Covid-19 pandemic at the high school education level.

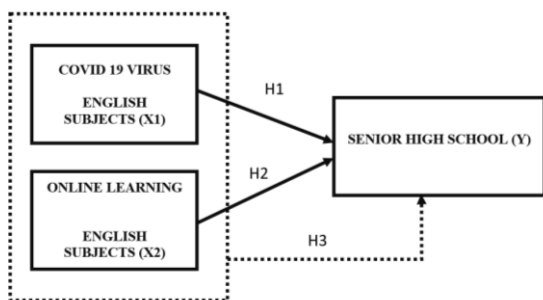

Figure 2. Hipotesis Model

RESULTS AND DISCUSSION

Table 1. Questions on the survey conducted on 100 people

No	Questions	Variable
1	Covid 19 virus is very dangerous	X1
2	Covid 19 virus changes everything	X1
3	Covid 19 virus affects the world of education	X1
4	Learn online the right advice during the covid 19 pandemic	X2
5	Online learning increases teacher knowledge	X2
6	Online learning can be anywhere and anytime	X2
7	Knowledge must continue to be given despite the covid 19 pandemic	Y
8	Senior high school can learn online and offline	Y
9	Senior high school must be able to use online	Y
10	Senior high schools can adapt to online learning because they are mature enough	Y

1. Multiple Linear Regression Analysis

a. Regression Equations

Table 2. Recapitulation of the Results of Multiple Linear Regression Analysis

Variable	Unstandardized Coefficients
Covid 19 Virus	2,334
Online Learning	0,654
Senior High School	0,367

Source: The Results of Data Processing

Based on table 2 above, the following explanation will be given, the Covid 19 Virus variable has an Unstandardized Coefficients value of 2.334, the Online Learning variable has an Unstandardized Coefficients value of 0.654 and the Senior High School variable has an Unstandardized Coefficients value of 0.367 which means it is very influential between one variable and another variable.

b. Koefisien Determinasi (R²)

Table 3. Correlation and Determination Coefficients

Dependent Variable	Independent Variable	R	R Square	Adjusted R Square
Y	X1 & X2	0,628	0,322	0,511

Source: The Results of Data Processing

Based on table 3 above, there are dependent variables, namely Y and independent variables, namely X1 and X2, variable X1 has an R value of 0.6 and variable X2 has an R value of 28, variables X1 and X2 have an R Square value of 0.322 and variables X1 and X2 has an Adjusted R Square value of 0.511, which means that the independent variable and the dependent variable have a very significant relationship.

c. Hypothesis Testing

c.1. Hipotesis I (F test / Serempak)

Table 4. F / Simultaneous Test

Dependent variable	Independent Variable	F Count	F Table 0,05	Sig .F	decision on H0
Y	X1 & X2	55,112	1,344	0,003	Ditolak

Source: The Results of Data Processing

Based on table 4 above, there are dependent variables, namely Y and independent variables, namely X1 and X2, variables X1 and X2 have an F Count value of 55.112 and variables X1 and X2 have an F Table value of 1.344, variables X1 and X2 have a Sig.F value, namely 0.003, X1 and X2 variables have a Decision on H0 value, namely Rejected, which means that there is a relationship between variables.

c.2 Hipotesis II (t test / Parsial)

Table 5. t / partial test results

Variable	t	Sig.
X1	3,453	0,003
X2	5,223	0,002

Source: The Results of Data Processing

Based on table 5 above, there are independent variables, namely X1 and X2, variable X1 has a t value of 3.453 and variable X2 has a t value of 5.223, variable X1 has a sig value of 0.003 and variable X2 has a sig value of 0.002 which means variable X1 and X2 has a very significant value to the dependent variable Y.

2. Discussion of Research Results

a. Hypothesis 1 (H1) variable Covid 19 Virus (X1) terhadap Senior High School (Y)

Based on the results of data processing above, the results of hypothesis testing 1 (H1) for the Covid 19 Virus (X1) variable against Senior High School (Y), the Covid 19 Virus (X1) variable has a significant relationship to the Senior High School (Y) variable.

b. Hypothesis 2 (H2) variable Online Learning (X2) terhadap Senior High School (Y)

Based on the results of data processing above, the results of hypothesis testing 2 (H2) Online Learning variable (X2) against Senior High School (Y), Online Learning variable (X2) has a significant relationship to Senior High School variable (Y).

c. Hypothesis 3 (H3) variable Covid 19 Virus (X1) dan Online Learning (X2) terhadap Senior High School (Y)

Based on the results of data processing above, the results of hypothesis testing 3 (H3) for the Covid 19 Virus (X1) and Online Learning (X2) variables against Senior High School (Y), the Covid 19 Virus (X1) and Online Learning (X2) variables have a relationship which is significant to the Senior High School variable (Y).

3. Descriptive Analysis

a. Covid 19 Virus Variables (X1)

Based on the results of the above research and data processing, it can be concluded that the Covid 19 Virus (X1) variable significantly affects the Senior High School (Y) variable, which means that the Covid 19 Virus variable that develops into a worldwide pandemic will greatly affect the world of education, especially at the level of education Senior high school.

b. Online Learning Variable (X2)

Based on the results of the research above and data processing, it can be concluded that Online Learning (X2) significantly affects the Senior High School (Y) variable, which means that the Online Learning variable has developed into one part of the educational media that greatly affects the world of education, especially at the senior high school level.

c. Senior High School Variable (Y)

Based on the results of the research above and data processing, it can be concluded that the Senior High School (Y) variable is significantly affected by the Covid 19 Virus (X1) and Online Learning (X2) variables, which means that the Senior High School (Y) is

good in learning even though there are many variables which affects him.

CONCLUSION

The conclusion based on the research above is that the Covid 19 Virus (X1) and Online Learning (X2) variables significantly affect Senior High School (Y), which means that the Covid 19 Virus (X1) affects the learning and teaching system at Senior High School (Y).) and the media that can be used during the covid 19 virus pandemic is Online Learning (X2), Senior High Schools are strongly influenced by the covid 19 virus variable and the online learning system because during the spread of the virus, it is not clear when the learning and teaching system ends. continue to be carried out even though it is done remotely, and online media.

REFERENCE

- [1] D. N. M. A. A. P. J. I. D. H. S. Y. C. Arman Syah Putra, "Examine Relationship of Soft Skills, Hard Skills, Innovation and Performance: the Mediation Effect of Organizational Le," *IJSMS*, pp. 27-43, 2020.
- [2] A. Damuri, N. Isnain, R. A. Priyatama, Y. I. Chandra and A. S. Putra, "E-Learning Proposal System in Public Secondary School Learning," *International Journal of Educational Research & Social Sciences (IJERSC)*, vol. 2, p. 270–275, 2021.
- [3] N. K. Dewi, . B. H. Irawan, E. Fitry and A. S. Putra, "Konsep Aplikasi E-Dakwah Untuk Generasi Milenial Jakarta," *IKRA-ITH INFORMATIKA: Jurnal Komputer dan Informatika*, vol. 5, no. 2, pp. 26-33, 2020.
- [4] N. K. Dewi and A. S. Putra, "Decision Support System for Head of Warehouse Selection Recommendation Using Analytic Hierarchy Process (AHP) Method," *Prosiding International Conference of Universitas Pekalongan*, pp. 1-12, 2021.
- [5] I. Ramadhan, A. Kurniawan and A. S. Putra, "Penentuan Pola Penindakan Pelanggaran Lalu Lintas di DKI Jakarta Menggunakan Metode Analytic Network Process (ANP)," *IKRA-ITH INFORMATIKA: Jurnal Komputer dan Informatika*, vol. 5, no. 1, pp. 51-57, 2020.
- [6] . V. H. Valentino, H. S. Setiawan, M. T. Habibie, R. Ningsih, D. Katarina and A. S. Putra, "Online And Offline Learning Comparison In The New Normal Era," *International Journal of Educational Research & Social Sciences (IJERSC)*, vol. 2, no. 2, p. 449–455, 2021.
- [7] V. Valentino, H. S. Setiawan, . A. Saputra, Y. Haryanto and A. S. Putra, "Decision Support System for Thesis Session Pass Recommendation Using AHP (Analytic Hierarchy Process) Method," *Journal International Journal of Educational Research & Social Sciences*, pp. 215-221, 2021.
- [8] A. S. Putra and L. H. S. W. Harco , "Intelligent Traffic Monitoring System (ITMS) for Smart City Based on IoT Monitoring," *Indonesian Association for Pattern Recognition International Conference (INAPR) IEEE*, pp. 161-165, 2018.
- [9] A. S. Putra, L. H. S. W. Harco , S. A. Bahtiar , T. Agung , . S. Wayan and H. K. Chu-, "Gamification in the e-Learning Process for children with Attention Deficit Hyperactivity Disorder (ADHD)," *Indonesian Association for Pattern Recognition International Conference (INAPR) IEEE*, pp. 182-185, 2018.
- [10] A. S. Putra, L. H. S. W. Harco , L. G. Ford , . S. Benfano and A. Edi , "A Proposed surveillance model in an Intelligent Transportation System (ITS)," *Indonesian Association for Pattern Recognition International Conference (INAPR) IEEE*, pp. 156-160, 2018.

-
- [11] M. S. Hartawan, A. S. Putra and A. Muktiono, "Smart City Concept for Integrated Citizen Information Smart Card or ICISC in DKI Jakarta," *International Journal of Science, Technology & Management*, pp. 364-370, 2020.
- [12] N. K. Dewi and A. S. Putra, "SISTEM PENUNJANG KEPUTUSAN PENERIMAAN KARYAWAN BARU DENGAN ALGORITMA GREEDY," *Jurnal Visualika*, vol. 6, no. 2, pp. 154-160, 2020.
- [13] N. K. Dewi and A. S. Putra, "Perkembangan Gamification dan Dampak Game Online terhadap Jiwa Manusia di Kota Pintar DKI Jakarta," *Jurnal Informatika Universitas Pamulang*, vol. 5, no. 3, pp. 315-320, 2020.
- [14] N. K. Dewi, I. Mulyana, A. S. Putra and F. R. Radita, "Konsep Robot Penjaga Toko Di Kombinasikan Dengan Pengendalian Virtual Reality (VR) Jarak Jauh," *IKRA-ITH INFORMATIKA: Jurnal Komputer dan Informatika*, vol. 5, no. 1, pp. 33-38, 2020.
- [15] N. K. Dewi and A. S. Putra, "Prosiding International Conference of Universitas Pekalongan," *Prosiding International Conference on Education of Suryakencana 2021 (ICONNECTS 2021)*, pp. 321-326, 2021.
- [16] N. K. Dewi and A. S. Putra, "LAW ENFORCEMENT IN SMART TRANSPORTATION SYSTEMS ON HIGHWAY," *Proceedings International Conference on Education of Suryakencana 2021*, pp. 321-326, 2021.
- [17] B. Givan, . R. Wirawan, D. Andriawan, N. Aisyah, A. and A. S. Putra, "Effect of Ease And Trustworthiness To Use E-Commerce for Purchasing Goods Online," *International Journal of Educational Research & Social Sciences (IJERSC)*, vol. 2, no. 2, p. 277-282, 2021.
- [18] A. S. Putra and . R. R. Fatrilia, "Paradigma Belajar Mengaji Secara Online Pada Masa Pandemic Coronavirus Disease 2019 (Covid-19)," *MATAAZIR: Jurnal Administrasi dan Manajemen Pendidikan*, pp. 49-61, 2020.