

# Design of Modified Chicken Feather Retractor Machine

Hatimi Mudin<sup>1,\*</sup>, Chicha Bagu<sup>1</sup>, Fethma M Nor<sup>2</sup>

<sup>1</sup> Department of Mechanical Engineering, No. 4, KKIP Barat, Politeknik Kota, Kinabalu, Jalan Politeknik, Sabah, Malaysia

<sup>2</sup> School of Design, Universiti Teknologi Brunei, Gadong BE1410, Brunei Darussalam

\* Correspondence: hatimimudin@gmail.com

Received: 20.07.2021; Accepted: 24.10.2021; Published: 31.12.2021

**Abstract:** The demand for poultry products is seen increasing from year to year. This is a good thing for local chicken entrepreneurs. But the task of plucking chicken feathers is time-consuming and tiring. The production of machines to help simplify the process of removing chicken feathers is seen as a necessity for these small and medium industrial entrepreneurs. This is why we focus on producing chicken feather retractor machines (CFRM) that are capable of processing up to five chickens at once. This machine is portable and easy to move around and supported by four wheels that can be locked to ensure stability. This machine can perform effectively to remove feathers using friction concept between the chicken and the plucker fingers rubber which attached around the drum. The machine also environmentally friendly by filtering the feather from scattered everywhere and only allow water to come out. The result shows that this machine operates under the motor powered with 115.13 rpm with the rotating plate area is 0.166 m<sup>2</sup> and drum volume of 0.158 m<sup>3</sup>. This machine managed to remove the feathers of up to five chickens within 30 seconds to 60 seconds.

**Keywords:** plucking, chicken feather, de-feather, poultry

---

## 1. Introduction

Chicken is the species most commonly produced around the world, followed by turkey and to a much lesser degree, by other species [1]. Chicken also amongst the largest source of protein and widely consumed by Malaysian people. Statistic of poultry consumption per capita in Malaysia from 2006 to 2019, with a forecast for 2025 (in Kilogram) as reported by OECD @ statista 2020 shows an average of 43kg per year consumed and this may increase to 19% as of the year 2025. Looking at the quantity and propensity of Malaysians who prefer to take chicken meat than other meats, the development of machines that can support the processing of chicken is something that is highly expected by SME entrepreneurs.

There are numbers of important activities involved in the production of poultry meat, these activities are; slaughtering, scalding, de-feathering process, eviscerating, chilling, deboning, packaging, and storing [2]. De-feathering process is identified as highly technical and time-consuming among the various numbers of poultry processing activities especially when carried

out manually [3]. Therefore, the construction of machines for the process of removing chicken feathers is what is most needed at this time. The common practice of plucking chicken feathers by hand not only results in health problems but also takes a long time to complete. This study focuses on the development of machines capable of processing chicken in large quantities and in a short period of time.

## 2. Materials and Methods

### 2.1 Material

The materials selection is based on efficiency, availability, cost, compatibility, and workability. These include weight, corrosion resistance, and safety of the materials. Table 1 shows the CFRM components and the selected material.

**Table 1.** The CFRM components and the selected materials

<b>Component</b>	<b>Material</b>
Frame	Steel angle bar
Drum	HDPE plastic
Disc	Aluminum
Rubber finger	Rubber

### 2.2 Method

#### 2.2.1 Design

This CFRM machine is designed with an emphasis on commercial, safety, and environmentally friendly features. Details of the CFRM 3D design are shown in Figure 1(a), (b), (c), and (d). The six (6) main components that play an important role in the mechanism of removing chicken feathers are labeled as in Figure 1(a).

The fabrication processes involved in this CFRM development is measuring, cutting, welding, drilling, and finishing [4,5]. Firstly, the components were measured to the accurate dimension as specified in the design. Then the measured part was cutting according to the measurement set. The body frame welded using TIG, MIG, and Arc welding. The finished body frame is painted as a coating to protect it from rusty. Mounted the rubber finger onto the Aluminum disc and then inserted the Aluminum disc at the drum's base. Drill a hole for rubber finger installation around the drum wall. Fix the rubber finger into the hole. The drum and the body frame are combined and attach the Aluminum disc to the shaft. The electric motor is installed and connected to the shaft rod by a belting system.

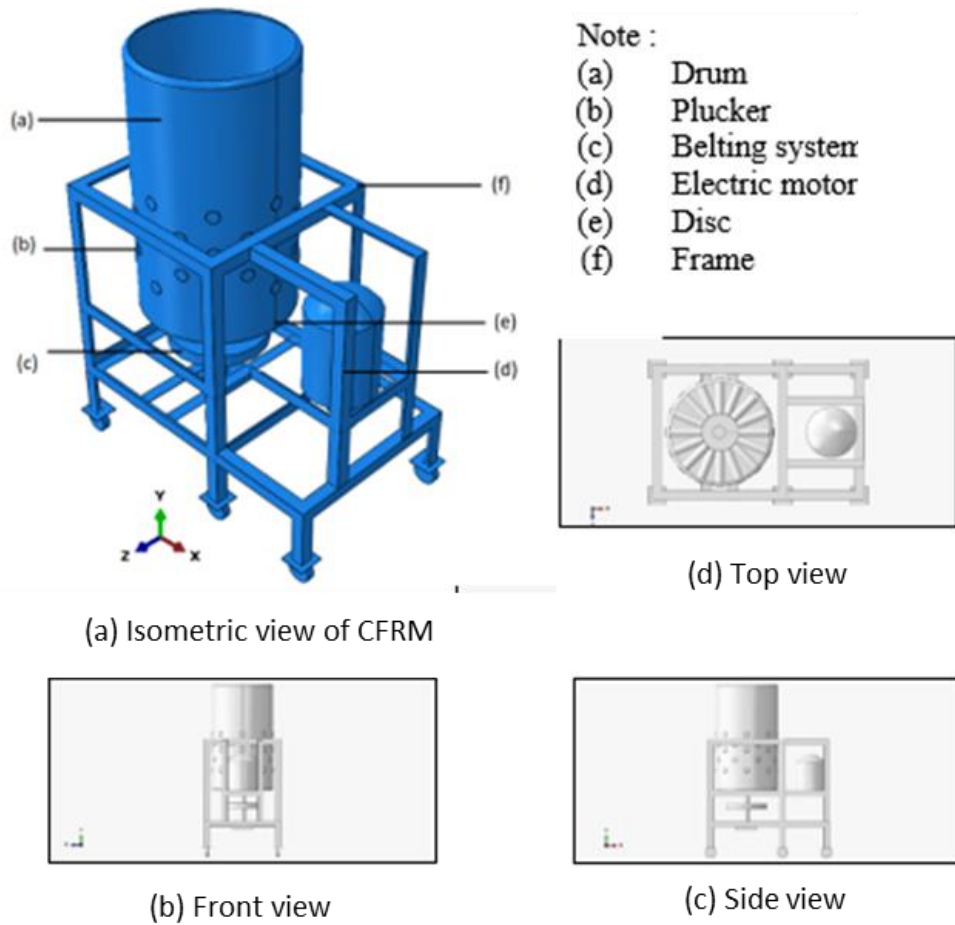

Figure 1. CFRM 3D design drawing

### 2.2.2 Working principle

The CFRM machine is powered by a 1hp electric motor which transmitting torques to the pulley by a belt. The pulley is connected to the shaft and thus the shaft drives the Aluminum disc against a stationary drum consisting of rubber finger mounted. The chicken inserted will be conveyed through the drum section and slide past the rubber finger on the drum wall and at the drum's base. The rubber finger get grip on the feather as the Aluminum disc rotating against the drum, thus pulled out the chicken feather. The removed feathers are then channeled through the designed passage by the helping of water that is supplied thru the incorporated hose. The feathers were collected in the reservoir where the feather is filtered for preventing them from contaminating the work area.

### 2.2.3 Machine evaluation

#### (a) De-feathering time

The performance of a chicken de-feathering machine depends on the speed of the machine and the Scalding temperature [6]. However, in this study, the temperature is not taken into consideration hence the time recorded may not the optimum time for the de-feathering process. Nevertheless, the time taken for CFRM is still considered better than the conventional method.

(b) Power requirement

The pulley system comprises two pulleys. The bigger, being the driven, is mounted on the shaft and the smaller pulley, the driver, is mounted on the electric motor. Since the diameter of the pulley on the motor is smaller, then there is a speed reduction (rpm) on the transmission to the larger pulley attached to the shaft. The speed of the motor is 1400 rpm (1HP). Formula (1) was used to calculate the speed that would be transmitted to the shaft [4].

$$N_1 D_1 = N_2 D_2 \tag{1}$$

where:

$N_1$  = Motor speed

$D_1$  = Motor pulley diameter

$N_2$  = Shaft pulley speed

$D_2$  = Shaft diameter

(c) Efficiency

The efficiency of the machine is determined by weighing the plucked feathers. Firstly, the feather was plucked by CFRM then the feather was collected weighing. The non-plucked feathers on the chicken were plucked manually and weighting together with the feather plucked by CFRM previously. Formula (4) is used to calculate efficiency.

$$E = \frac{W_1}{W_2} \times 100 \tag{2}$$

Where:

$W_1$  = Initial weight of chicken’s feather plucked by CFRM

$W_2$  = Total weight of chicken’s feather (Pluck by CFRM and manually)

### 3. Result and Discussion

#### 3.1 De-feathering time

Time taken for manually de-feathering and CFRM de-feathering is recorded as in Table 2. The process of de-feathering by using CFRM is eight times faster than the conventional method. CFRM can reduce de-feathering time by 88% to 96%.

**Table 2.** Time taken for the de-feathering process

Number of chickens	Conventional	CFRM
	Time taken (sec)	Time taken (sec)
1	249	30
2	492	36
3	816	43
4	1122	51
5	1404	60

The graph plotted in Figure 3 shows that the time to remove the chicken feathers by the conventional method increased sharply with the number of chickens. This might be because the long working hours tire the employee. In contrast to the graph for CFRM, the increment is slowly and consistently.

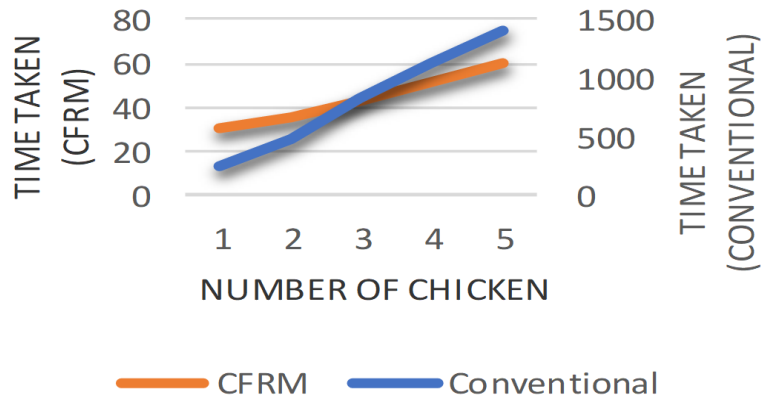

Figure 3. De-feathering time taken for the conventional method and CFRM method

The power requirement can be calculated as follow:

$$N_2 = \frac{1,400 \times 25}{304}$$

$$N_2 = \frac{35,000}{304}$$

$$N_2 = 115.13 \text{ rpm}$$

From the calculation, the machine speed is 115.3 rpm. Various machine speed was used by researchers before, but to my observation, there are many variable parameters to be manipulated to get the best outcome.

Table 3. Feather weight plucked by CFRM and manually

Number of chickens	Feather weight plucked by CFRM	Feather weight plucked by CFRM and manually	Efficiency
	(kg)	(kg)	
1	0.16	0.16	100
2	0.27	0.28	96
3	0.44	0.50	88
4	0.69	0.71	97
5	0.78	0.82	95

Calculating of the efficiency average =  $\frac{100+96+88+97+95}{5}$

The efficiency average = 95.2%.

The average efficiency of CFRM calculated during the testing is 95.2%. Nevertheless, this efficiency is fluctuate depending on the number of chickens processed as seen in Table 3. The folded parts are the most difficult to de-feather. It can be seen from the table that the lowest effectiveness is on three numbers of chickens. This condition occurs because there is no standard measure of how long or how clean the chicken should be before the machine could be turned off. Therefore, at this time, the machine may be turned off too early.

#### 4. Conclusions

The CFRM has successfully achieved the aims. The usage of CFRM can help SME businessmen increase their production by shortening the number of de-feathering processes and processing up to five (5) chickens at once. The price is still in the affordable range to own, and the CFRM efficiency may help produce more chicken meat to supply the demand of consumers by the year 2025. There are several plans for the improvement of this project. The simplification of the design is required. A recyclable material also can be used to replace the rubber finger. Apart from helping to promote recycling for a better environment, the cost also can be cut down. Finally, the scalding process can be included in the machine function to shorten the time to process a poultry product.

#### References

- [1] S. Barbut, *Poultry products processing : An Industry Guide*, Boca Raton, FL, Florida: CRC Press, 2002, p. 6.
- [2] M. S. Abubakar, A. S. Muhammad and A. O. Salihu, "Evaluation of a modified chicken de-feathering machine," *Nigerian Journal of Engineering Science and Technology Research*, vol. 4, no. No.1, pp. 1-7, 2018.
- [3] Adetola, S. O., Onawi, A. S. and Lucas, E. B., "Investigation on into mechanized de-feathering process of optimal scalding temperature of exotic and local Birds in Southwestern Nigeria," *Transnational Journal of Science and Technology*, pp. 12 (26-35), 2012.
- [4] Omoniyi Ezekiel B, Peter Oyekola, Onoriode Ovaha, Aezeden Mohamed, Nicholas Lambrache, "Bird Feather Removal Machine: Design and Development," *International Journal of Recent Technology and Engineering (IJRTE)*, vol. 8, no. 3, 2019.
- [5] Omidiji B. V., Owolabi H.A., Oyenuga A. A. and Adeleke A. A., "Development of Chicken De-feathering Machine," *Journal of Engineering and Engineering Technology*, vol. 8, no. 1, pp. 7-12, 2014.
- [6] M. Abubakar, A. Zakariyah and A. Usman, "Design, construction and performance evaluation of chicken de-feathering machine," *Arid Zone Jour. of Eng. Technol. & Env.* vol. 15, pp. 702-713, 2019.



This is an open-access article distributed under the terms of the Creative Commons Attribution 4.0 International License (CC-BY).