

Gender Mainstreaming Problems in Student Organizations at Islamic Religious Colleges

Rr. Rina Antasari¹, Nilawati², Helen Sabera Adib³, Renny Kurnia Sari⁴, Dolla Sobari⁵

¹ UIN Raden Fatah Palembang, Indonesia; rinaantasari_uin@radenfatah.ac.id

² UIN Raden Fatah Palembang, Indonesia; nilawati_uin@radenfatah.ac.id

³ UIN Raden Fatah Palembang, Indonesia; helensaberaadib_uin@radenfatah.ac.id

⁴ UIN Raden Fatah Palembang, Indonesia; rennykurniasari_uin@radenfatah.ac.id

⁵ UIN Raden Fatah Palembang, Indonesia; dollasobari_uin@radenfatah.ac.id

ARTICLE INFO

Keywords:

Gender Mainstreaming;
Student Organizations;
Gender Equality

Article history:

Received 2021-12-22

Revised 2022-02-17

Accepted 2022-06-11

ABSTRACT

This study aims to analyze gender mainstreaming in student organizations from the basic aspects, student understanding, and policy implementation in several Islamic religious universities. This research is normative-empirical. This study found that implementing gender mainstreaming in student organizations was not optimal from the legal aspect, student understanding, and implementation. From the legal aspect, they have not included a philosophical foundation with the value of gender justice and equality, have not made a wise local academic culture the basis for sociological considerations, and have not included a juridical basis related to the acceleration of gender mainstreaming. From the aspect of student understanding of gender, it is still very low, which is indicated by the composition of the Intra-Campus Student Organization (OMIK) in strategic positions dominated by men. And from the aspect of implementation, it has not been optimal due to among others the commitment of the academic community to the enforcement of gender-responsive policies is still low and the activities in the field of student affairs that are carried out are not based on gender analysis.

This is an open access article under the [CC BY-NC-SA](https://creativecommons.org/licenses/by-nc-sa/4.0/) license.



Corresponding Author:

Rr. Rina Antasari

UIN Raden Fatah Palembang, Indonesia; rinaantasari_uin@radenfatah.ac.id

1. INTRODUCTION

Gender mainstreaming is a contentious concept and practice by nature. It involves rediscovering, restructuring, and rebranding an important part of feminism in the contemporary era. This is a new form of political practice and gender policy as well as a new strategy for development. Gender mainstreaming is a process to promote gender equality that aims to increase the effectiveness of mainstreaming policies by making assumptions, processes and outcomes based on gender. Gender

mainstreaming encapsulates many of the tensions and dilemmas in feminist theory and practice over the past decade and provides a new focus for debates about how to mobilize them (Walby, 2005).

Gender mainstreaming can be defined in some ways, all of which are contested in one way or another (March, Smyth, & Mukhopadhyay, 1999; Woodford-Berger, 2007). The most common usage in Sweden is as a long-term strategy or systematic institutional approach for promoting/producing gender equality as a policy outcome. However, there is a great deal of confusion and contestation surrounding the concept itself (Sida, 1996; Woodford-Berger, 2007). Gender mainstreaming is a strategy employed to achieve gender equality and equity by considering the experiences, aspirations, needs and problems of women and men in planning, implementing, monitoring and evaluating all policies and programs of various sectors of social development (P. Indonesia, 2000). Gender mainstreaming aims at planning, implementing, monitoring and evaluating national development policies and programs with a gender perspective (Malau, 2014).

The theme of research on the discourse and practice of gender equality is still hotly underway in Islamic higher education institutions. Moreover, religious factors are significant for social change efforts toward a gender-just society. Resistance and support are intertwined, thus influencing the success rate of gender mainstreaming. The dimensions of the policy and its realization that are gender-just flow into the realm of the role and function of Islamic higher education in society. Then it is integrated in the institutional structure, which is polarized into scientific specialization. The scientific dynamics that are the focus of the study and the driving actors will affect the color of discourse and praxis on gender justice. As a result, the implementation and achievement of efforts to integrate gender issues in all educational processes will vary (Kusmanto, 2017).

Gender mainstreaming in the entire development process will be successful if it is based on in-depth gender analysis. Gender analysis is an effort to map/identify and understand the presence or absence and causes of gender inequality and injustice, including solving problems. Gender analysis is a process that includes: 1) identifying the gaps between men and women in benefiting from development policies and programs in various aspects of life; 2) identifying and understanding the causes of gender inequality and injustice and compiling the causes; 3) develop the necessary steps to achieve gender equality and justice; and 4) establish gender indicators to measure the achievements of efforts to achieve gender equality and justice (Nugroho, 2008).

Gender equality and justice is important in every country in seeking equal rights between men and women. Indonesia is a country based on norms as an agreed-upon necessity and a culture that grows depending on the values of each existing custom. The growing culture causes women to be discriminated against, violent, and even poorly labeled, thus placing women in a weak group. The role of the person in charge of domestic affairs has limited women's movement in the domestic sphere. This inequality is exacerbated by the political and social system that makes men more dominant than women (Ardhini & Alfirdaus, 2022; Fakhri, 2012).

Islamic Religious Colleges (PTKI) as agents of social change are asked to be able to play their functions dynamically and proactively in responding to various realities that are increasingly developing in a global context (Ali, 2009; Angkawijaya, 2017; Sri, 2012). The past feudal culture, traditional thoughts and attitudes surrounding the campus's intellectual mindset which are actualized in daily life on campus are soon abandoned. It is time for Islamic Religious Universities to be able to bring about meaningful changes and contributions to the improvement of the ummah, both at the theoretical and practical intellectual levels. One of the elements of the academic community that needs attention and can determine the progress of a higher education institution is the student. As Law Number 12 of 2012 Article 13 states that students as members of the academic community are positioned as adults who have their own awareness in developing their potential in Higher Education to become intellectuals, scientists, practitioners, and/or professionals (R. Indonesia, 2012).

Student life which is always dynamic and developing is also influenced by internal and external conditions of the campus where they study. In Higher Education, a forum is provided as a vehicle for personality development and increasing intellectual insight called the intra-college student organization

(R. Indonesia, 1998). The forum at Islamic Religious Colleges, called the Intra-Campus Student Organization (OMIK), consists of the Student Executive Council (DEMA), the Student Senate (SEMA), the Study Program Student Association and the Student Work Unit (UKM) and the Special Student Work Unit (UKMK) (R. Indonesia, 2016a). OMIK's contribution is aimed at fostering and developing personality to achieve the functions and goals of educating the life of a dignified nation and developing the potential of students to become pious, knowledgeable and charitable human beings and able to learn how to think, learn how to do, learn how to be, and learning how to live together (R. Indonesia, 2016b).

In addition to what has been explained above, the Intra-Campus Student Organization (OMIK) steps are also required to be able to deconstruct the campus socio-cultural values which still seem to ignore the values of Gender Equality and Justice (KKG) (P. Indonesia, 2000). To strengthen this, the Ministry of Religion asked to coordinate, integrate and synchronize Gender Mainstreaming (PUG) activities in every Islamic Higher Education, including the student affairs sector, especially in Intra-Campus Student Organizations (P. Indonesia, 2020).

Based on the results of initial observations, in the State Islamic Religious Universities (PTKIN) throughout Sumatra, within the last 4 years the values of gender equality and justice are still far from being realized in OMIK management and the form of their work programs. Men seem to be the dominant party in the OMIK management steps. This condition is undoubtedly an exciting issue to be researched. The gender disparity is very large, especially for strategic position holders such as the Chair of OMIK starting from the Chair of the Student Executive Council (formerly known as the Student President/Presma), Chair of the Student Senate, Head of Student Activity Units and Units. Especially for State Islamic Religious Universities throughout Sumatra, almost 97% of the positions in question are held by men, while women only occupy more feminine positions. In other words, the representation of women in OMIK management in strategic positions is very low, even almost non-existent. This phenomenon does not reflect the teachings of the Qur'an in the letter al-Hujurat verse 3 that Allah SWT. created humans on earth in pairs, upholding equality and justice, not being discriminated against and what distinguishes them is the level of piety.

As the above phenomenon shows the existence of gender disparities in the world of student organizations (ORMAWA) within PTKI, especially PTKIN throughout Sumatra, of course there is a connection with the legal umbrella governing the field of student organizations (ORMAWA), namely the Decree (SK) of the Director General of Higher Education. Islamic Religion Number 4961 of 2016 concerning General Guidelines for Student Organizations at Islamic Religious Colleges. So it is necessary to assess the substance of the decree about Gender Mainstreaming, including the principles and basis for forming the decree and setting quotas for men and women in management. All of them are important to study considering that OMIK can be said as a miniature of democratic political learning (Simbolon, 2019).

Furthermore, in the study of the Decree of the Director-General of Islamic Higher Education Number 4961 of 2016 concerning General Guidelines for Student Organizations at Islamic Religious Universities, the gender mainstreaming perspective can also be seen from the selection of OMIK management through the General Election (PEMIRA) or carried out by representatives. Based on observations, the representation of those who voted was dominated by women, while men dominated those who were elected. This means that for the time being, it can be said that gender mainstreaming as a strategy towards gender equality and justice based on experience in the selection process for the management of OMIK has not been realized.

There have been many previous studies related to gender mainstreaming, such as Kusmanto's research (2017), Witriani (2019), Mufidah (2011), Indriyani (2021), Fibrianto (2016), Mahpur (2006), and other research. However, what distinguishes it from previous research is the research subject, area, and focus of the study. The focus of the study is the implementation of the Decree of the Director General of Islamic Religious Higher Education Number 4961 of 2016 concerning General Guidelines for Student Organizations at Islamic Religious Colleges about the concept of gender mainstreaming. There are three

issues, namely first, revealing the philosophical, juridical and sociological basis for issuing the decree. Second, the understanding of the management of OMIK PTKIN throughout Sumatra about gender sensitivity in an organization. And third, explain the implementation of the decree.

2. METHODS

This research is normative-empirical. The object of this research is 23 State Islamic Religious Universities (PTKIN) in Sumatra. This research was conducted from May to September 2021. The primary source in this research is the Decree of the Director General of Islamic Religious Higher Education Number 4961 of 2016 concerning General Guidelines for Student Organizations at Islamic Religious Colleges. While the secondary data in this study is documentation and questionnaires. This study's data collection techniques were observation, interviews, and documentation. The informants interviewed were 12 vice chancellors, 12 Student Executive Council (DEMA), 12 Student Senate (SEMA), and 5 vice dean III for student affairs and cooperation.

Furthermore, the analysis is carried out qualitatively. This is because in analyzing an object of research, this method is used to explain the data used. The data in question describes the data from interviews, legal regulations relating to research problems, library study data, and literature related to research problems.

3. FINDINGS AND DISCUSSION

3.1. Philosophical, Juridical and Sociological Basis Decree of the Director-General of Islamic Religious Higher Education Number 4961 of 2016 concerning General Guidelines for Student Organizations at Islamic Religious Universities

The philosophical basis is a consideration or reason that illustrates that the regulations that are formed take into account the views of life, awareness, and legal ideals which include the spiritual atmosphere and the philosophy of the Indonesian nation originating from Pancasila and the Preamble to the 1945 Constitution (Redi, 2018). The philosophical basis is the philosophical basis or view of life that becomes the basis of ideals when pouring desires into a draft/draft of the legislation. For the Indonesian people, the philosophical basis is Pancasila, so in principle, it is not made and statutory regulation is made if it is contrary to Pancasila as the philosophy and basis of the Indonesian state (Laila & Daliwu, 2022).

Philosophically, the issuance of the Decree of the Director-General of Islamic Religious Higher Education Number 4961 of 2016 concerning General Guidelines for Student Organizations at Islamic Religious Colleges aims to encourage students to become members of the community who have academic and/or professional abilities who can apply, develop, and create knowledge, technology and/or arts with Islamic nuances. In addition, it is also to develop and disseminate science, technology and/or art, talents and interests as well as strive for their use to improve people's living standards and enrich national culture with Islamic nuances and national insight (R. Indonesia, 2016a). Philosophically, this decree is the practice of the 5th precept of Pancasila which implies equal rights for all people, both women and men. Rights and obligations are not only owned by one particular group, but are intended for every element of society.

As a policy, the decision letter within the scope of its application involves the participation of women and men, so the philosophical considerations found only use the basis of justice and order. It is time to add the value of gender equality as a philosophical foundation. So that the policy or regulation does not seem gender-neutral.

The sociological basis is a consideration or reason that illustrates that regulations are formed to meet the community's needs in various aspects. The sociological basis concerns empirical facts regarding the development of problems and needs of society and the state. In other words, the sociological basis is a foundation consisting of points which are the demands of the community's needs

that encourage the need for making laws and regulations, namely that there is something that is needed by the community so that regulation is needed (Laila & Daliwu, 2022).

Campus is an environment that has a uniqueness with the community called the academic community (academic community). It is said so, because campus residents carry out academic activities that are curricular, co-curricular and extra-curricular. The academic community is a category of society whose citizens have the characteristics of wanting to know all existing phenomena, by carrying out scientific activities, to obtain proven truths according to scientific methods. For this reason, the academic community has a systematic and systemic framework of thinking based on facts and data and the ability to analyze to obtain a tested truth. Such conditions do not mean that there is a tendency that the academic community is exclusive, but rather as a form of selective action to maintain its distinctive character and image. In addition to the existence of tradition, in an academic society there is a need for common rules that bind and regulate its citizens. Traditions and regulations are a unit that synergistically regulates the orderly academic community on campus. If tradition provides stability to academic life on campus, then regulations are outlined for a forum for adjustment and renewal. The orderliness of the academic community on a campus will be well maintained if academic traditions and applicable regulations are used as behavioral guidelines by the academic community and other campus elements (R. Indonesia, 2016a).

Students as one element of the campus both individually and in groups in student organizations have a broad dimension. Apart from being part of the academic community (scientific dimension) they are also part of the youth community (social dimension) and have future tasks and challenges. With awareness of their obligations and rights, students can develop their potential in all the dimensions attached to them. The PTKI student organization as a vehicle for personality development and increasing insight and intellectuality is one part of the overall academic system at PTKI. His contribution is aimed at fostering and developing personality to achieve the functions and goals of educating the life of a dignified nation and developing the potential of students to become pious, knowledgeable, and charitable human beings, and able to "learning how to think, learning how to do, learning how to do." to be, and learning how to live together." So, intra-campus student organizations are a vehicle for improving leadership and reasoning abilities and channeling interests and hobbies. In seeking life experiences and developing their potential through student organizations, students are not only required to prioritize truth and honesty but also to always prioritize the values of multiculturalism among campus residents. As members of the academic community, students are required to exist with their conditions and are not justified in imposing the values, norms and ethics of "non-campus society" onto universities. Such conditions can lead to confusion due to a discrepancy between one norm and another. This discrepancy to some extent, can lead to conflict (R. Indonesia, 2016a).

The sociological basis for issuing the decree departs from the reality in the campus community and implementing reforms within the Islamic Religious College. The reality is in the form of growing aspirations, existing problems and demands for a change of location for the sake of the changes. For example, it is responding to the general election system for OMIK management from the General Election system (PEMIRA) to a representative system. According to Ruchman Basori, PEMIRA often triggers conflict, causes riots, damages facilities and so on (Ayu, 2019). From a sociological perspective, it can be said that the basis used in this case is limited to efforts to minimize or eliminate riots due to the existence of PEMIRA and the need for management. Regarding the consideration of academic culture which has been lasting and certainly will not cause riots or other undesirable things, it has not been taken into consideration. In this case there is a good thing to be defended. Because the academic culture used generally refers to the local culture of the local community in general.

Furthermore, the juridical basis is a consideration or reason that illustrates that regulations are formed to overcome legal problems or fill legal voids by considering existing rules, which will be changed, or which will be revoked to ensure legal certainty and a sense of justice for the community (Redi, 2018). The juridical basis concerns legal issues related to the substance or material regulated, so it is necessary to form new laws and regulations. Some of these legal issues are outdated regulations,

inharmonious or overlapping regulations, types of regulations that are lower than the law so that their enforcement power is weak, the regulations already exist but are inadequate, or the regulations do not exist at all (Laia & Daliwu, 2022). The juridical basis for the decision letter is only based on several legal norms/regulations with binding power to the public as a dogma seen from juridical technical considerations, namely based on superior or higher legal norms. Other sources of law in the form of rules that regulate the acceleration of gender mainstreaming have not been used as the juridical basis for forming the decree.

3.2. Governance of Intra-Campus Student Organizations (OMIK) at State Islamic Religious Universities in Sumatra with a Gender Sensitive Perspective

There are 3 types of State Islamic Religious Universities: universities, institutes and high schools. Especially for the Sumatra area, there are 8 universities, 10 institutes, and 4 high schools. Good student governance at each campus will help build the government's potential in various fields. To make this happen, one of the initial steps students take is through student organizations on campus. Student organizations at Islamic Religious Universities are regulated in the Decree of the Director-General of Islamic Education Number 4961 of 2016 concerning General Guidelines for Student Organizations at Islamic Religious Universities. Arranged in a structure chart as follows:

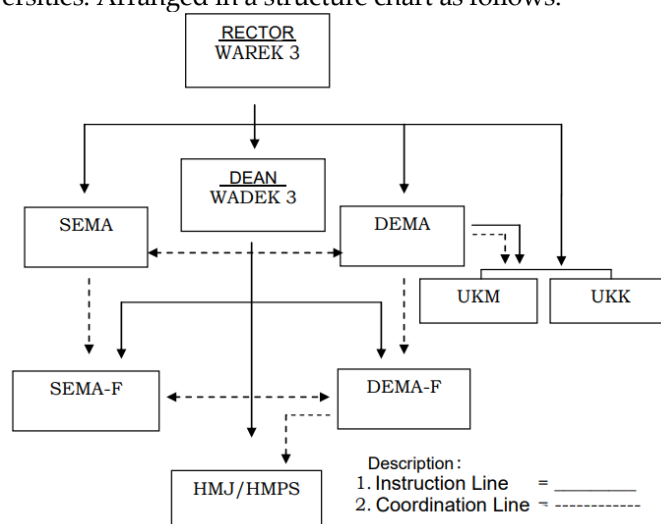

Figure 1. Student Organization Structure of PTKI Universities and Institutes (R. Indonesia, 2016a)

Based on the student organization structure (ormawa) at PTKIN throughout Sumatra, it was found to be in accordance with the structure stipulated in the Decree of the Director General of Islamic Education Number 4961 of 2016 concerning General Guidelines for Student Organizations. However, when viewed from the line of workflow, some are instructive and some are coordinated, some confusion is found in the implementation of duties and responsibilities. Others were found to exist between sections that have two workflow line signs, namely instructive and coordinating. Even though it's quite instructive or vice versa. This was also said by respondent Ir, who was seen from the relationship between the University Student Executive Council (DEMAU) with the Student Activity Unit (UKM) and the Unique Student Activities Special (UKK) there were two lines, namely the instructive and coordinating lines. Suppose there is a task line for instructions. In that case, these conditions will limit SMEs' work space/programs, especially UKKs because they wait for instructions to be continued or prohibited by DEMAU.

Meanwhile, UKM or UKK already have direct instructional lines with the Chancellor or Vice Chancellor/Vice Chair in charge of student affairs. Respondent Ni saw that between SEMAU and DEMAU and SEMAF and DEMA-F there should be two lines of command, namely the instructive and

the coordinating line of command, not just the coordinating one. Thus, it is hoped that there will be excellent programs or news from the scope of higher education so that it can be easily known and passed down to the faculty, and vice versa.

Thus, it can be said regarding the student organization structure regulated in the Decree of the Director-General of Islamic Education Number 4961 of 2016 concerning General Guidelines for Student Organizations, most respondents said it needed to be reviewed, because it was difficult to understand the workflow. Moreover, to realize a gender-sensitive understanding. So it can be emphasized that there is an instructive and coordinating workflow between DEMA, UKM, and UKK. It's better if only one, considering that SMEs or UKK have their own uniqueness that DEMA administrators do not necessarily understand. In addition, not all SME and UKK compensations are in the DEMA management structure. It is feared that there will be an interactive vacuum, the goal will not be achieved and the dominant sub-ordination condition may occur, especially if the resources are of different sexes. It will be easier for discrimination to occur. Therefore, it is sufficient to use a coordinating workflow line between DEMA and UKM/UKK. Then between DEMA with HMJ and HMPS the workflow is coordinated. Meanwhile, according to the responses of several respondents, in this case there are actually two lines of command, namely coordinating and instructive. Given their profiles, their duties and functions are the same, it's just a different areas.

Then from the findings in the field related to the understanding of OMIK management about gender sensitivity is still weak. Their understanding is only limited if women's access is more dominant in the organization then it is considered equal and the condition is considered gender-sensitive. Meanwhile, women who exist and become members of Ormawa have their position in the organization's management, not in the strategic part or in policymakers. So close to the label of feminist stereotype roles. Whereas gender sensitivity is needed to create equal distribution of benefits. Gender sensitivity is the principle of realizing gender justice and equality (Sofiani, 2013), that is a condition in which the share and social cycle of women and men are equal, harmonious, balanced and harmonious (S. Indonesia, 2016). This finding confirms the opinion of Triana Sofiani (2013) that the condition that only sees the involvement of women more in an activity/organization can be said to understand gender and gender equality and justice have been realized. Whereas the measure is whether women get a place and fair treatment between women and men. The application of gender equality and justice must take into account contextual and situational issues, not only seen and based on mathematical calculations and is not universal. So the concept of gender-sensitive equality is a philosophical concept that is qualitative in nature, not necessarily quantitative in nature.

The understanding of the management of OMIK PTKIN throughout Sumatra regarding whether women may hold positions as Chairmen in Ormawa. In response to this question, there are two groups. The first group stated that while there are still men, why should women. Because in the Qur'an it is said that men are priests. The understanding of this group has not been able to distinguish gender roles and functions for women and men in the public sphere and which ones are for the domestic sphere and how religion actually teaches the position of men and women as beings who are both caliphs on earth. Meanwhile, the second group stated that a woman could become the head of DEMAU or any other chair, on condition that the woman must be capable, strong and truly like men. The statement of the second group indicates that the understanding of the management of OMIK PTKIN throughout Sumatra about gender and gender mainstreaming is still low. While related to the word gender and gender mainstreaming, most respondents said that they had heard of it and even received counseling, but it could not be realized at the implementation stage.

3.3. Implementation of the Decree of the Director General of Islamic Religious Higher Education Number 4961 of 2016 concerning General Guidelines for Student Organizations with Gender Mainstreaming Perspectives

Gender mainstreaming (PUG) as a strategy in the planning system to promote equality between women and men in development that is integrated into every program or policy (Gainau, 2018; Natalis,

2020). This integration must be supported by seven prerequisites for implementing Gender Mainstreaming as stated in circulars from four ministries, namely commitments, policies, institutions, resources, disaggregated data, analytical tools, and community networks/participation (Harya, 2018; Penyusun, 2012). The implementation of the decree in the field will be linked to the seven prerequisites for gender mainstreaming with the following findings:

a. Commitment

The State Islamic Religious Universities' leadership throughout Sumatra in Student Affairs and the OMIK management have not fully stated their commitment to making PUG a strategy in carrying out/implementing the Decree of the Director-General of Islamic Religious Higher Education. As for what causes the low commitment, namely the lack of understanding of leaders, especially in the student sector regarding Gender Mainstreaming (PUG) and Minister of Religion Decree (KMA) Number 571 of 2020 concerning Gender Mainstreaming Working Groups at the Ministry of Religion. Thus, the commitment requirements in implementing the decree will automatically be low.

b. Policy

In implementing the decree, the perspective of Gender Mainstreaming cannot be separated from policy. The most important policy in implementing Gender Mainstreaming in every aspect of development, including the student sector, is Presidential Instruction No. 9/2000 on Gender Mainstreaming in National Development, which is a policy of the Government of Indonesia in responding to the implementation of PUG in development. Inpres Number 9 of 2000 has also been followed up by the Ministry of Religion with the issuance of Decree of the Minister of Religion (KMA) Number 571 of 2020 concerning the Working Group on Gender Mainstreaming at the Ministry of Religion. Of several State Islamic Religious Universities throughout Sumatra, almost 90% have made derivative policies from the Decree of the Director General of Islamic Education Number 4961 of 2016 concerning General Guidelines for Student Organizations. However, none of these derived guidelines/policies contain the principle of gender mainstreaming in the substance of the policy, so they are still gender neutral.

c. Institutional

Institutional requirements for gender mainstreaming are important because they become a forum for accelerating PUG in every development aspect. It is clearly stated in KMA that forming a Gender Mainstreaming group at the Ministry of Religion at the central level, Religious Universities, provinces, and districts/cities. All of this is so that the national program mandated through Presidential Instruction No. 9/2000 is realized at the Ministry of Religion. According to the opinion of several respondents, especially from the Vice Chancellor/Vice Chair for Student Affairs, no institution in the student sector specifically addresses the acceleration of Gender Mainstreaming because no regulations confirm it. In addition, back to the understanding of the management of the field of student affairs which is still minimal about gender and Gender Mainstreaming. However, on a macro level, every Islamic Religious Universities, including State Islamic Religious Universities in Sumatra, which carry out the acceleration of Gender Mainstreaming are carried out by the Center for Gender and Child Studies (PSGA).

d. Resource

Human resources and budget are two things that are difficult to separate because they are a vital element in a program/institution as a determinant of success, including determining the implementation of the decree. Regarding human resources in the field of student affairs who master gender science and gender mainstreaming, respondents acknowledge that Hm is still very few. If the field of student affairs requires a study on gender or talks about gender, the field of student affairs asks for resource persons from the Center for Gender Studies. To increase knowledge, understanding and professionalism of human resources regarding gender mainstreaming in the field of student affairs at State Islamic Religious Universities throughout Sumatra, policy makers in the field of student affairs seek to make

such programs, for example through socialization, workshops, training and mentoring and others. Meanwhile, the problem of funding for the student sector receives funding from the Universities.

e. Dissaggregated data

Dissaggregated data can also be called insight-opening data, which is data or information to show whether or not there is a gender gap (Antasari & Hadi, 2017). This is a key condition for conducting a gender situation analysis. Insight-opening data can be in the form of: 1) sex-disaggregated data that explains the level of inequality, and 2) data or information that describes special incidents that cannot be compared between genders, for example data on OMIK's management structure, OMIK's work program with a gender perspective and harassment. sex on campus. The type of disaggregated data is in the form of quantitative and qualitative data. While the characteristics of disaggregated data are 1) disaggregated by sex: gender analysis, 2) disaggregated by socio-economic group: poverty analysis, 3) disaggregated by age: cohort analysis; 4) disaggregated by region: spatial analysis, and 5) disaggregated by time: time series analysis (Antasari & Hadi, 2017).

Of the fourteen PTKIN throughout Sumatra, particularly in student affairs, it is still difficult to find disaggregated data. Some of the reasons for this include not understanding what disaggregated data is, having never received socialization about the importance of disaggregated data, the weak desire to collect data in the form of disaggregated data and institutionalizing it. No specific policy requires data concerning gender in PTKIN, especially at PTKIN all over Sumatra.

f. Analysis tools

Gender analysis tools are part of the prerequisites for implementing gender mainstreaming to determine the existence of gender gaps in an institution. In conducting gender analysis, many methods can be used, including the Gender Analysis Pathway (GAP), Problem Based Approach (PROBA), and other methods (Setyawan, Firdausi, & Rusmiwari, 2018). However, in the Ministry of Women's Empowerment and Child Protection and BAPPENAS, the Gender Analysis Pathway (GAP) method is more dominant because it is recommended in the Presidential Instruction number 9 of 2000 (Penyusun, 2013). In general, gender analysis aims to formulate program policies and development activities by taking into account gender situations, conditions and needs. Gender analysis is used from the planning, budgeting, implementation, monitoring and evaluation stages of program policies and activities in various aspects of development. Islamic Religious Universities throughout Sumatra have never conducted a gender analysis using any method due to the respondent's lack of understanding.

g. Networking/Community Participation

Community involvement in a series of collaborative networks to accelerate gender mainstreaming is very much needed. Because strengthening institutions in terms of accelerating gender mainstreaming cannot be done by one party. With a network of cooperation involving community participation, common interests and goals can be realized, namely creating justice based on gender equality. Network collaboration is strengthened by the Regulation of the Minister of Women's Empowerment and Child Protection of the Republic of Indonesia Number 2 of 2017 concerning Community Participation in the Development of Women's Empowerment and Child Protection. In essence, the Ministerial Regulation emphasizes that everyone has the right to participate in development, assisting the government in empowering women and children so that there is no discrimination. State Islamic Religious Universities throughout Sumatra in the field of student affairs in making and implementing work programs in general already exist that involve community participation, but specifically regarding the acceleration of gender mainstreaming has never been done.

The Decree of the Director-General of Islamic Religious Higher Education Number 4961 of 2016 concerning General Guidelines for Student Organizations at Islamic Religious Colleges needs to be reviewed. First, in the preamble, the decision still needs to be clarified, including the basis for philosophical, sociological and juridical considerations. Second, there is no legal basis for gender mainstreaming in the considering (consideration) section. Third, it is necessary to add the article's contents regarding the proportion between men and women in the requirements for recruiting OMIK administrators. Fourth, confirming the election system for the Chair of OMIK at various levels, whether

to use a representative system, whether submitted to the local cultural habits of a polite academic community, by way of general election or a mixture of representatives and PEMIRA.

Thus, the Decree of the Director General of Islamic Religious Higher Education Number 4961 of 2016 concerning General Guidelines for Student Organizations at Islamic Religious Universities in the perspective of Gender Mainstreaming has not been optimal and has barely been touched. Therefore, as a formal educational institution of religious-based Islamic State Universities throughout Sumatra, it is time to have strategic power to produce and/or reproduce new gender-based teachings or doctrines in the Islamic context, which can be disseminated by involving all elements in it (stakeholders) towards a gender-responsive Islamic Religious College. In this regard, several things that need to be done by the academic community include 1) increasing a committed understanding of gender-responsive policies; 2) create policies and institutions that support the implementation of gender mainstreaming; 3) educational data is made in the form of disaggregated data; 4) readiness of human resources and funding for the implementation of gender-responsive policies; 5) in making programs, gender analysis is carried out; 6) foster attitudes and alignments for gender-responsive policies; 7) strengthening the network interacting with the community (community participation); and 8) the bureaucratic structure to be used also reflects gender responsiveness.

4. CONCLUSION

This study concludes that firstly, the decree has not included a philosophical basis for the value of justice and gender equality (philosophical foundation); has not made the wise local academic culture the basis for sociological considerations (sociological basis); and does not include the juridical basis related to the acceleration of gender mainstreaming (juridical basis). Second, the understanding of the management of OMIK PTKIN throughout Sumatra about gender sensitivity in an organization is still low. This condition can be seen from the composition of the OMIK management, especially in strategic positions dominated by men. And third, the implementation of the decree has not been optimally carried out, even barely touched, due to among other things the commitment of the academic community to the enforcement of gender-responsive policies is still low; policies and institutions that support the implementation of gender mainstreaming have not been maximized; lack of understanding to create and use disaggregated data; lack of human resources and funding for the implementation of gender mainstreaming towards gender responsive policies; activities/programs in the field of student affairs that have not been carried out based on gender analysis; and a network of interacting with the community (community participation) to carry out gender mainstreaming towards a gender responsive campus is still lacking. Suggestions for further research is the implementation of gender mainstreaming in the curriculum in each subject.

REFERENCES

- Ali, M. (2009). *Pendidikan untuk pembangunan nasional: Menuju bangsa Indonesia yang mandiri dan berdaya saing tinggi*. Bandung: Imperial Bakti Utama.
- Angkawijaya, Y. F. (2017). Peran Perguruan Tinggi sebagai Agen Perubahan Moral Bangsa (Studi Kasus Peran Konsep Diri terhadap Karakter Mulia pada Mahasiswa di Universitas X Surabaya). *Widyakala Journal*, 4(1), 36. <https://doi.org/10.36262/widyakala.v4i1.29>
- Antasari, R. R., & Hadi, A. (2017). Implementasi Kebijakan Perencanaan dan Penganggaran yang Responsif Gender di Pemerintah Kota Palembang. *AL-MAIYYAH: Media Transformasi Gender Dalam Paradigma Sosial Keagamaan*, 10(1), 132–161.
- Ardhini, S. A., & Alfirdaus, L. K. (2022). Kebijakan Anggaran Responsif Gender di Kota Pekalongan Tahun 2016-2020. *Journal of Politic and Government Studies*, 11(2), 132–147.
- Ayu, R. D. (2019). Menyikapi Sistem Pemilihan Umum. Retrieved from LPMINSTITUT.COM website: <http://www.lpminstitut.com/2019/03/menyikapi-sistem-pemilihan-umum.html>
- Ch, M. (2011). Strategi Implementasi Pengarusutamaan Gender Bidang Pendidikan Islam. *Al-Tahrir*:

- Jurnal Pemikiran Islam*, 11(2), 391–414.
- Fakih, M. (2012). *Analisis Gender dan Transformasi Sosial*. Yogyakarta: Pustaka Pelajar.
- Fibrianto, A. S. (2016). Kesetaraan Gender Dalam Lingkup Organisasi Mahasiswa Universitas Sebelas Maret Surakarta Tahun 2016. *Jurnal Analisa Sosiologi*, 5(1).
- Gainau, P. C. (2018). Urgensi Penerapan Anggaran Responsif Gender Di Pemerintah Daerah. *BIP's JURNAL BISNIS PERSPEKTIF*, 10(2), 126–143.
- Harya, G. I. (2018). Rencana Aksi Daerah Pengarusutamaan Gender Kabupaten Pacitan. *Jurnal Ilmiah Sosio Agribis*, 18(2).
- Indonesia, P. (2000). *Instruksi Presiden Republik Indonesia (Inpres) Nomor 9 Tahun 2000 Tentang Pengarusutamaan Gender Dalam Pembangunan Nasional*. Jakarta: Republik Indonesia.
- Indonesia, P. (2020). *Peraturan Menteri Agama (PMA) No. 571 tahun 2020 tentang Kelompok Kerja Pengarusutamaan gender*. Jakarta: Kementerian Agama.
- Indonesia, R. (1998). *Keputusan Menteri Pendidikan dan Kebudayaan Republik Indonesia Nomor 155 /U/1998 Tentang Pedoman Umum Organisasi Kemahasiswaan di Perguruan Tinggi Menteri Pendidikan dan Kebudayaan*. Jakarta: Kementerian Pendidikan dan Kebudayaan.
- Indonesia, R. (2012). *Undang-Undang Republik Indonesia Nomor 12 Tahun 2012 Tentang Pendidikan Tinggi*. Jakarta: Kementerian Riset, Teknologi, dan Pendidikan Tinggi.
- Indonesia, R. (2016a). *Keputusan Direktur Jenderal Pendidikan Islam Nomor: 4961 Tahun 2016 Tentang Pedoman Umum Organisasi Kemahasiswaan Pada Perguruan Tinggi Keagamaan Islam*. Jakarta: Kementerian Agama.
- Indonesia, R. (2016b). *Lampiran Keputusan Direktur Jenderal Pendidikan Islam Nomor: 4961 Tahun 2016 Tentang Pedoman Umum Organisasi Kemahasiswaan Pada Perguruan Tinggi Keagamaan Islam*. Jakarta: Kementerian Agama.
- Indonesia, S. (2016). *Percentage of Population Aged 10 Years and Over by Province, Gender, and Marital Status, 2009-2015*.
- Indriyani, I. A., Hikmawan, M. D., & Utami, W. K. (2021). Gender dan Pendidikan Tinggi: Studi tentang Urgensitas Kampus Berperspektif Gender. *JiIP: Jurnal Ilmiah Ilmu Pemerintahan*, 6(1), 55–72.
- Kusmanto, T. Y. (2017). Dinamika Pengarusutamaan Gender Pada Pendidikan Tinggi Islam. *Sawwa: Jurnal Studi Gender*, 12(3), 303–320.
- Laia, S. W., & Daliwu, S. (2022). URGENSI LANDASAN FILOSOFIS, SOSIOLOGIS, DAN YURIDIS DALAM PEMBENTUKAN UNDANG-UNDANG YANG BERSIFAT DEMOKRATIS DI INDONESIA. *JURNAL EDUCATION AND DEVELOPMENT*, 10(1), 546–552.
- Mahpur, M. (2006). Persepsi Civitas Akademika UIN Malang Terhadap Pengarusutamaan Gender. *EGALITA*, 1(2). <https://doi.org/10.18860/egalita.v0i0.1929>
- Malau, W. (2014). Pengarusutamaan Gender dalam Program Pembangunan. *JUPIIS: Jurnal Pendidikan Ilmu-Ilmu Sosial*, 6(2), 125–131.
- March, C., Smyth, I. A., & Mukhopadhyay, M. (1999). *A guide to gender-analysis frameworks*. Oxfam.
- Natalis, A. (2020). Urgensi Kebijakan Penyelenggaraan Anggaran Pendapatan dan Belanja Daerah dalam Mewujudkan Kesejahteraan Perempuan. *Pandecta Research Law Journal*, 15(1), 64–73.
- Nugroho, R. (2008). *Gender dan Administrasi Publik: Studi tentang Kualitas Kesetaraan Gender dalam Administrasi Publik Indonesia Pasca Reformasi 1998 – 2002*. Yogyakarta: Pustaka Pelajar.
- Penyusun, T. (2012). *Strategi Nasional Percepatan Pengarusutamaan Gender (PUG) Melalui Perencanaan Dan Penganggaran Yang Responsif Gender (PPRG)*. Jakarta: Kementerian Perencanaan Pembangunan Nasional/ Badan Perencanaan Pembangunan Nasional (BAPPENAS).
- Penyusun, T. (2013). *Modul Training of Fasilitator (TPF) Perencanaan Penganggaran Yang Responsif Gender*. Jakarta: Kementerian Pemberdayaan Perempuan dan Perlindungan Anak.
- Redi, A. (2018). *Hukum Pembentukan Peraturan Perundang-undangan*. Jakarta: Sinar Grafika.
- Setyawan, D., Firdausi, F., & Rusmiwari, S. (2018). Analisis Program Perencanaan Penganggaran Responsif Gender (Studi di Dinas Pemberdayaan Perempuan, Perlindungan Anak,

- Pengendalian Penduduk dan Keluarga Berencana Kota Batu Jawa Timur). *Publisia: Jurnal Ilmu Administrasi Publik*, 3(1), 64–72.
- Sida, S. I. D. C. A. (1996). *Mainstreaming: Concept, Strategies and Methodologies – A Think Piece*. Stockholm: Sida.
- Simbolon, Y. Y. (2019). Rumah Pintar Pemilu Sebagai Strategi Komunikasi Komisi Pemilihan Umum (KPU) Dalam meningkatkan Partisipasi Pemilih Pemula PEMULA. *COMMED Jurnal Komunikasi Dan Media*, 4(1), 16–32.
- Sofiani, T. (2013). Membangun Kampus (STAIN Pekalongan) Yang Sensitif Gender. *MUWAZAH: Jurnal Kajian Gender*, 4(2).
- Sri, Y. (2012). Kajian implementasi tri dharma perguruan tinggi sebagai fenomena pendidikan tinggi di Indonesia. *Widya*, 29(318), 28–33.
- Walby, S. (2005). Gender mainstreaming: Productive tensions in theory and practice. *Social Politics: International Studies in Gender, State & Society*, 12(3), 321–343.
- Witriani, W., & Kusuma, B. M. A. (2019). Mapping Isu Jurnal Berbasis Pengarusutamaan Gender dan HAM Pada Perguruan Tinggi di Indonesia. *Musāwa Jurnal Studi Gender Dan Islam*, 18(1), 45–59.
- Woodford-Berger, P. (2007). 10 Gender mainstreaming: what is it (about) and should we continue doing it? *Feminisms in Development: Contradictions, Contestations and Challenges*, 122.