



Research Article

## Digital Stethoscope to Examine Patients According to Technical Guidelines of Covid-19

Muhammad Ilhamdi Rusydi <sup>1\*</sup>, M. Farhan <sup>1</sup>, Yoan Winata <sup>1</sup>, Dhiny Yurichy Putri <sup>2</sup>, Muhammad Dani Anwar <sup>1</sup>, Daelita Berliana H. <sup>3</sup>

<sup>1</sup> Electrical Engineering, Faculty of Engineering, Universitas Andalas, Padang, Indonesia

<sup>2</sup> Industrial Engineering, Faculty of Engineering, Universitas Andalas, Padang, Indonesia

<sup>3</sup> Medicine, Faculty of Medicine, Universitas Andalas, Padang, Indonesia

### ARTICLE INFORMATION

Received: November 16, 2021

Revised: November 21, 2021

Available online: December 13, 2021

### KEYWORDS

Covid-19, auscultation, stethoscope, digital

### CORRESPONDENCE

Phone: +62 812-6156-6525

E-mail: [rusydi@eng.unand.ac.id](mailto:rusydi@eng.unand.ac.id)

### A B S T R A C T

Health professionals have to use Personal Protective Equipment (PPE) that could cover the entire body to prevent the transmission of the SARS-CoV-2 virus while examining patients. The current stethoscope is not compatible with the need of health professionals. Therefore, this project aims to create a digital stethoscope that can fulfill the requirement of health professionals to examine patients according to health service guidance in Covid-19 era. Three main objectives in designing the stethoscope are to meet the needs of health professionals, easy and convenient to use. The designed stethoscope has an amplifier circuit with 100 gain and a bandpass filter with 20 Hz and 700 Hz for low and high cut-off frequencies. It is also able to calculate the heart rate and displays it on the stethoscope screen. The stethoscope has a record function that lets the users replay sound as much as they need for the analysis. This digital stethoscope has function tests, performance tests and user satisfaction tests. Seven health professionals who are well-experienced in handling Covid-19 patients auscultate and provide an assessment of the three objectives design. The test results showed that this stethoscope satisfies the health professional's requirements to examine the patient, grade 4.69 of 5. Health professionals also give a perfect rating for the objective of being easy to use. This stethoscope is the right choice for examining patients according to health service guidance in the Covid-19 era.

### INTRODUCTION

The World Health Organization or WHO announced that the 2019 Coronavirus Disease had become a global pandemic on March 12, 2020 [1]. Covid-19 cases in Indonesia are increasing, as of August 27, 2021, 4.07 million positive cases of Covid-19 have been confirmed in Indonesia [2]. Covid-19 is a disease caused by the Severe Acute Respiratory Syndrome Coronavirus-2 (SARS-CoV-2). This disease can spread through small droplets from the nose or mouth of patients when coughing, sneezing, and breathing [3].

Health professionals who treat Covid-19 patients have a very high risk of contracting it because they often contact patients [4]. It was recorded that in August 2021 cases of death of health professionals due to Covid-19 had reached 1,967 cases of death [5]. Therefore, it is important for health professionals to wear Personal Protective Equipment (PPE) as protection when providing health services. PPE Level 3 is the highest level of PPE used when providing services to avoid droplets of Covid-19 patients. PPE level 3 consists of hazmat (hazmat hazardous

materials suit), goggles, face shield, gloves, boots, and so on [4]. The use of level 3 PPE that completely covers the body can reduce the risk of transmission from patients to health professionals. But on the other hand, it also creates difficulties and inconveniences in using medical devices that do not support this situation, such as the use of a stethoscope [6][4].

The stethoscope, as an iconic medical device [7][8] is used to check the patient's health by listening to internal sounds or auscultation [9]. A stethoscope is very important for examining Covid-19 patients, especially those with severe symptoms such as acute respiratory failure [10]. Generally, these symptoms look like viral pneumonia or pneumonia due to infection [11][12]. Pneumonia has specific characteristics that are related to the radiological picture of Covid-19 patients. Auscultation using a stethoscope is an initial physical examination to diagnose pneumonia by listening for abnormal breath sounds [13].

In addition to pneumonia, heart disorders are often found in Covid-19 patients, such as myocardial injury, myocarditis, and acute coronary syndrome. Disorders of heart rhythm can also occur after treatment with QT-prolonging drugs [14]. These

disorders can lead to heart failure if not treated quickly and appropriately. The difference in heart rates and pulse rates is an early sign of heart failure that must be detected quickly. Monitoring the electrical activity of the heart is also necessary when examining patients with heart rhythm disorders.

The stethoscope commonly used today is the acoustic stethoscope which uses tubing to connect the diaphragm and earpieces [15]. Reference [6] said that acoustic stethoscopes are challenging to use when treating Covid-19 patients because there is no gap in level 3 PPE to insert a tubing. In terms of quality, the sound that can be heard through this acoustic stethoscope is also shallow [16]. Apart from the difference in human hearing sensitivity, some sounds transmitted by acoustic stethoscopes become inaudible, such as frequencies less than 50 Hz [17]. The transmission process reduces auscultation accuracy [18]. The shortcomings of acoustic stethoscopes raise the need for a stethoscope breakthrough that can be used by health professionals comfortably while still applying technical guidelines for health services during the Covid-19 period.

The solution so that the stethoscope can be easily used when wearing level 3 PPE is to use an electric stethoscope connected to a headphone. However, this type of stethoscope is still difficult to use because it still uses a cable for the headphone [6]. The connector between the stethoscope and the headphone is also vulnerable to damage, so it still causes problems. This solution also does not meet the needs of health professionals for monitoring the patient's electrical activity and heart rate. Another existing solution is a digital stethoscope that connects to a smartphone and earbud wirelessly. However, the use of an earbud for a long time can cause discomfort and interfere with hearing function [19]. This digital stethoscope must also be connected to the application on the device so that its use becomes less practical. Procurement of an apparatus for each stethoscope is also not economical, while personal devices can increase the risk of virus contamination [20].

This activity aims to create a stethoscope that can answer the challenges of examining patients in accordance with technical guidelines for health services during the Covid-19 period. This stethoscope has three main objectives, namely, providing convenience and comfort when used according to the needs of health professionals. The importance of auscultation proves that health professionals need a stethoscope that can produce good sound quality. Another need is a stethoscope that can be used even when health professionals wear level 3 PPE and the comfort of health professionals. Health professionals can use this digital stethoscope comfortably because there is no need to unplug PPE and without fear of being contaminated with viruses when examining patients. Another advantage of this tool is that it can display electrical activity and heart rate per minute and record auscultation sound so that it is easier to detect organ disorders according to the needs of monitoring the heart's electrical activity in patients. In addition, the recording feature is also helpful for digitally recording patient medical records and advances in science and technology. This tool is also equipped with a screen and does not require the help of a device so that it is more practical, economical and reduces the risk of virus contamination.

**METHOD**

This digital stethoscope is made with steps starting from problem identification, determination of specification requirements, design and implementation of tools, testing, analysis to repair. These steps are illustrated by Figure 1.

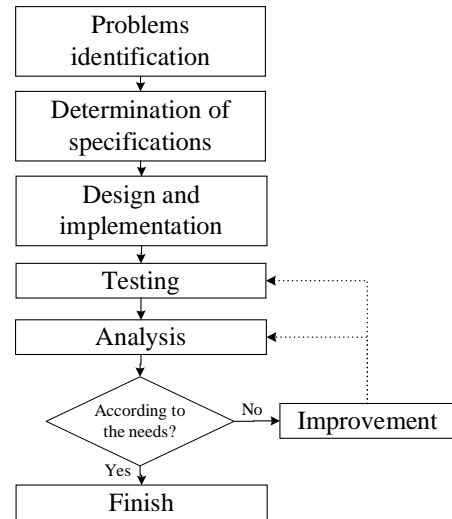

Figure 1. Flowchart of the Implementation Stage

***Problem Identification and Determination of Specifications***

Problem identification is made by directly discussing with two doctors who treat Covid-19 patients and through literature studies on existing solutions. This discussion is useful for knowing the conditions and problems faced by health professionals regarding the use of stethoscopes during the Covid-19 pandemic. The stethoscopes commonly used by health professionals are the acoustic stethoscope in Figure 2(a) and the electric stethoscope connected to the headphone in Figure 2(b).

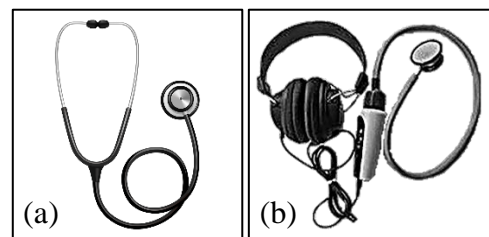

Figure 2. (a) Acoustic Stethoscope  
(b) Stethoscope with Headphone

The results of problem identification are taken into consideration in formulating a solution plan for each problem. Each solution plan has specifications to meet the needs, convenience, and comfort of using a stethoscope during the Covid-19 pandemic.

***System Design and Implementation***

The schematic design of the digital stethoscope system is described in Figure 3. Input in the form of auscultation sounds is detected using a condenser mic connected to the tubing. The detected sound in an analog signal is forwarded to the pre-amp

circuit, first amplifier, filter, and second amplifier. The processed signal is forwarded to four types of output. The first output of a stethoscope is the auscultatory sound produced by a wired audio device. The second output is the Bluetooth-based wireless audio device. The third output is a screen display that provides information on the electrical activity of the heart and the number of heartbeats per minute. The final output is auscultation sound recording stored in digital memory and can be listened to again.

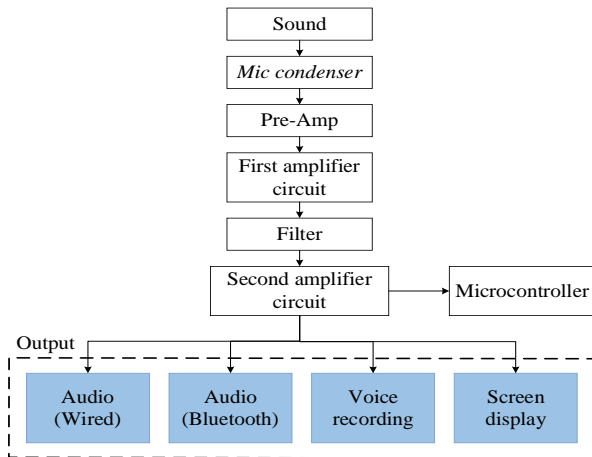

Figure 3. Schematic of the Tool

**Testing and Analysis**

This digital stethoscope test has obtained an ethical license with No. 555/UN.16.2/KEP-FK/2021 from the Research Ethics Commission, Faculty of Medicine, Universitas Andalas. This digital stethoscope is tested for function and performance. Functional tests of this stethoscope include wired and wireless communication function tests, sound recording feature function tests and visualization function tests of the heart's electrical activity and the number of heartbeats per minute. Performance tests against digital stethoscope specifications include signal amplifier circuit tests, filter circuits, wireless operating range and energy consumption.

The user satisfaction test was carried out on seven health professionals who have experience in handling Covid-19 patients. This user satisfaction test is related to three predetermined objectives: the need for auscultation examinations, convenience, and comfort of health professionals when using them. Health professionals are asked to use a stethoscope made to listen for heart sounds, breath sounds, bowel sounds, and blood vessel sounds at auscultation points. In addition, health professionals are also testing the visualization feature and recording the heart's electrical activity. After using this stethoscope, health professionals are asked to provide an assessment of three objectives.

**RESULTS AND DISCUSSION**

**Stethoscope Specification**

The digital stethoscope was created by considering three objectives: the needs, convenience, and comfort of health professionals when examining patients according to technical

guidelines for health services during the Covid-19 period. A discussion was held with two doctors regarding using an acoustic stethoscope and an electric stethoscope with headphones. The problems faced by health professionals who are divided based on their objectives can be seen in Table 1. Acoustic stethoscopes have not met any of the issues required by health professionals to examine patients. An electric stethoscope with headphones has good sound quality, can be used with level 3 PPE and has a low risk of virus contamination. However, the drawbacks of the two stethoscopes are the subjectivity of the sound being heard and the convenience based on the type of output.

Table 1. Problems with Acoustic and Electric Stethoscopes

Objectives	Issue	Acoustic	Electric
Needs	Sound quality	×	✓
	Available to be used when PPE level 3	×	✓
	Subjectivity	×	×
Convenience	Lots choice communication	×	×
Comfort	Risk virus contamination low	×	✓

Based on the needs of health professionals for the shortcomings of acoustic and electric stethoscopes, an objective diagram for the design of the new stethoscope is formulated, as illustrated in Figure 4. Each issue in the stethoscope has a solution to solve the problem. The main advantage of this digital stethoscope is the availability of both wired and wireless communication options. In addition, visualization of the electrical activity of the heart and the ability to record sound are also features that can make it easier for health professionals. This stethoscope can be used without having to remove level 3 PPE when examining patients, so the risk of virus contamination is low. It aims to increase the comfort of health professionals.

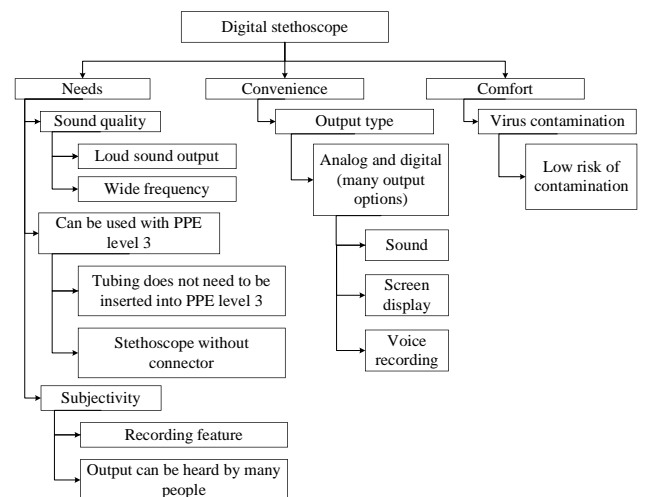

Figure 4. The objective diagram of the Digital Stethoscope

The stethoscope specification has been determined based on the analysis of the objective diagram to ensure that the digital stethoscope has answered the needs of health professionals and pays attention to the convenience and comfort of its use. The stethoscope specification consists of nine categories with

supporting variables. These specifications are available in Table 2.

Table 2. Specifications of Digital Stethoscope

Category	Variable	Specification Device
Communication	Cable	Mono
	Wireless	Bluetooth 4.2
	Wireless operating distance	Maksimal 8 m
Body	Dimensions	76,62 x 50 x 28,69 mm
	Mass	240 g
	Material	PLA+
Screen display	Type	UG-2864HLBEG01
	Size	21,74 x 10,86 mm
	Resolution	128 x 64 pixel
Microcontroller	Type	ATmega 328P
	Clock speed	16 MHz
	Flash memory	32 KB
	EEPROM	512 Bytes/1 KB
Amplifier	Type	TDA 2822
	Magnitude	100 times
Filter	Type	Band pass filter
	Cut off	20 – 700 Hz
Battery	Type	Lipo E-model
	Capacity	2200 mAh
	Voltage	7,4 Volt
Storage	Type	MicroSD card
Operational voltage		5 Volt
Energy consumption		4,4 Watt

**Result of Design and Implementation**

The digital stethoscope has a four-part electrical system consisting of a pre-amp, a first amplifier, a filter, and a second amplifier. The pre-amp serves to convert a weak sound signal into a strong enough signal to be further processed into the first amplifier circuit. The first amplifier circuit serves to amplify the sound signal and is then filtered on the filter circuit. The filtered signal is then amplified again so that the sound signal is clearer. The output of the design is analyzed to see that the system response has succeeded in filtering and amplifying according to the design. The graph of the system response signal can be seen in Figure 5.

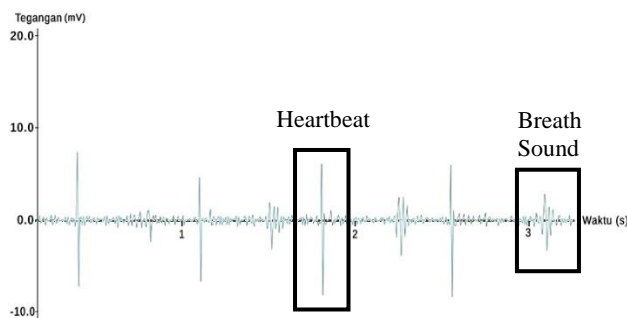

Figure 5. Output Signal Graph

It can be seen in Figure 5 that the heart rate and breath signals have been successfully expelled clearly. After designing the electrical system of the stethoscope, the mechanical design and layout of the components used in the stethoscope are carried out. There are several parts and components used in a stethoscope as shown in Figure 6.

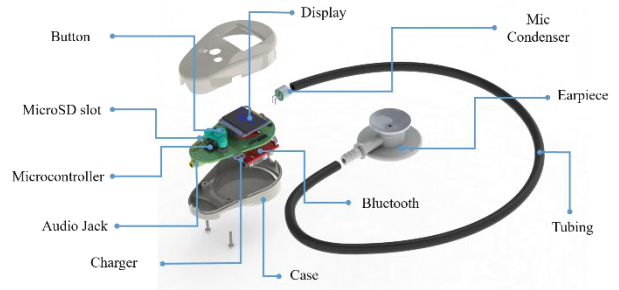

Figure 6. Parts of a Digital Stethoscope

**Function Test**

Functional testing includes four aspects as shown in Table 3. Functional testing of wired and wireless communication features has been carried out by listening to the auscultated sound using various connected audio devices. Wired communication is tested by listening to the sound through the speaker and headphones. Meanwhile, the wireless communication test was carried out through an earbud, headphones, and a Bluetooth-based loudspeaker. The result of this test is that the auscultation sound can be heard through audio devices, both wired and wireless.

Table 3. Functional Test Results of Digital Stethoscope

No	Aspect	Status
1	wired communication features	Functionate
2	wireless communication features	Functionate
3	Activity and heart rate visualization features	Functionate
4	Auscultation voice recorder features	Functionate

Testing of the electrical activity display features of the heart and the number of heart beats per minute is also carried out by auscultation and viewing the visualization results on the stethoscope screen as shown in Figure 7. The X axis shows the time in seconds and the Y axis shows the amplitude. The cardiac electrical activity graph may appear on the display screen for a maximum of 10 seconds and will shift continuously. The number of heart beats per minute is calculated for 10 seconds which results will be multiplied by 6 to produce the number of heart beats for 1 minute.



Figure 7. Digital Stethoscope Screen Visualization

The sound recording feature has been tested by auscultating, recording, and listening again. The recorded sounds are heart sounds, breath sounds, bowel sounds, and blood vessel sounds. After being recorded, the auscultation sounds are stored on a microSD, then listened to again using loudspeakers and a laptop. The recorded sound that is heard through loudspeakers and laptops can already be heard and is the same as the auscultatory sound that is heard live.

**Performance Testing**

**Signal Amplifier Circuit Test**

The function of the amplifier circuit is to amplify the sound signal. The amplifier circuit on a digital stethoscope can be seen in Figure 8. The first amplifier circuit and the second amplifier use the TDA 2822M Op-Amp IC. The magnitude of the amplifier circuit gain on a digital stethoscope is 100 times the gain according to equation (1).

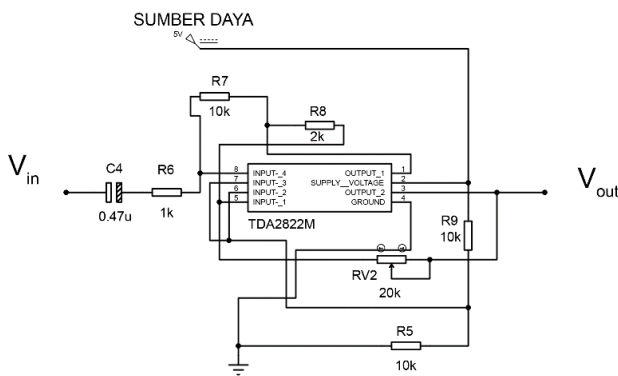

Figure 8. Dual Amplifier Circuit

$$\text{Gain} = \frac{V_{out}}{V_{in}} \tag{1}$$

**Filter Circuit Test**

The function of the filter circuit is to pass signals with a specific frequency range and eliminate signals outside that frequency. The filter used is a type of bandpass filter, namely a filter that combines a high pass filter and low pass filter in one circuit. The high filter will cut the frequency value below its frequency point, while the low filter will cut it above the limit point. The limit

value of the bandpass filter is obtained by analyzing the sound signal using the Fast Fourier Transform (FFT) method. FFT is an algorithm to convert a signal in the time domain into a frequency domain to separate the constituent frequencies in the input signal. This domain changes to get the frequency of heartbeat, breath, and noise. A filter with a frequency range of 20 – 700 Hz was designed using a bandpass filter based on the analysis results. The bandpass filter circuit has been able to work correctly according to the cutting limit value. Figure 9(a) shows the graphic form of the heart rate sound frequency before filtering and Figure 9(b) graph after filtering.

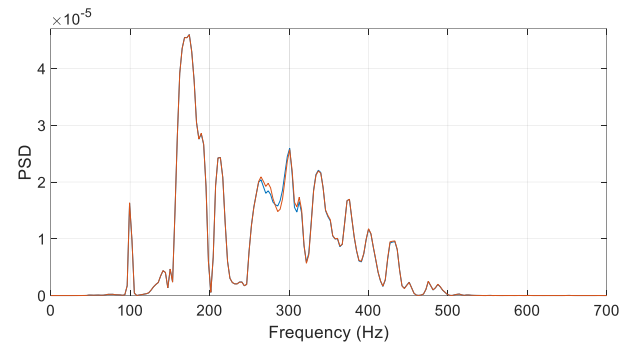

(a)

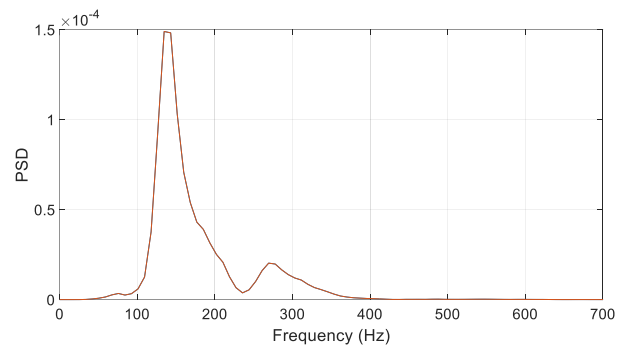

(b)

Figure 9. (a) Heartbeat Sound Frequency Before Filtered (b) Heartbeat Sound Frequency After Filtered

Breath sound analysis also uses the same method to obtain a frequency graph of the breath sound signal before filtering in Figure 10(a) and after filtering in Figure 10(b).

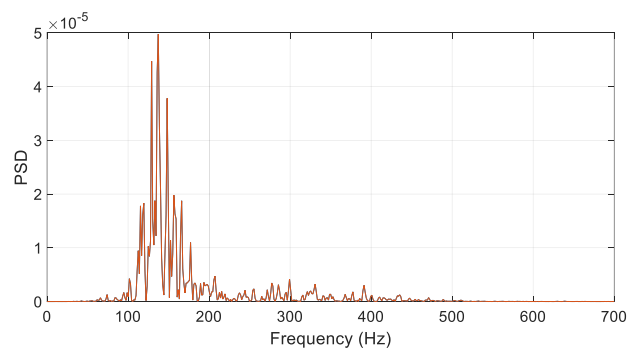

(a)



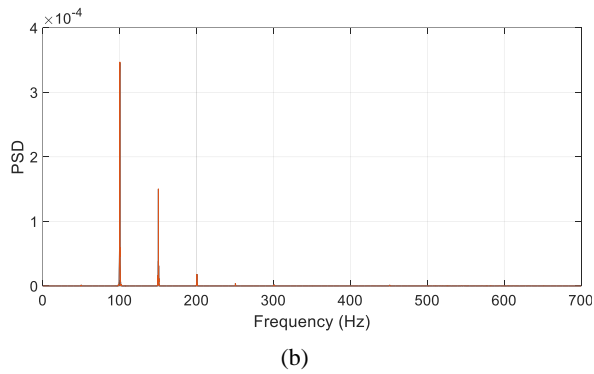

Figure 10. (a) Breath Sound Frequency Before Filtered  
(b) Breath Sound Frequency After Filter

The filter circuit used in this digital stethoscope can be seen in Figure 11. The filter used is a bandpass filter using a TDA 2822M IC.

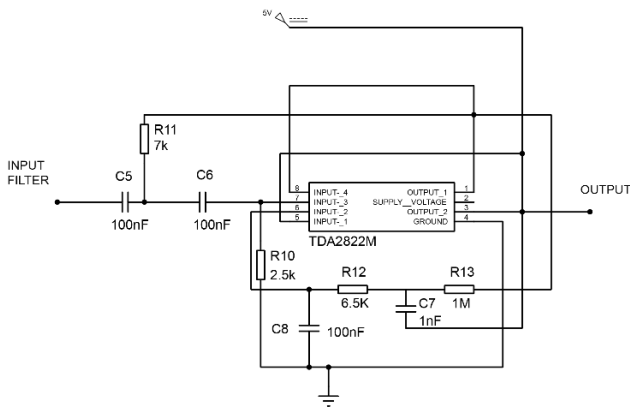

Figure 11. Band Pass Filter Circuit

**Wireless Operating Distance Test**

This digital stethoscope can operate wirelessly in both open and closed spaces. Distance experiments have been carried out to test the operating distance using a stethoscope. The experimental results can be seen in Table 4. Based on the experimental results, it can be concluded that this digital stethoscope can be used wirelessly in both open and closed spaces.

Table 4. Wireless Operating Distance Experiment Results

Test	Max Distance (meter)
Open space	8
Open space with partitions	7,7
Closed space	7,5

**Energy Consumption Test**

The battery used in this digital stethoscope has a capacity of 2200 mAh. Energy consumption testing has been carried out to see the length of time the battery used in the digital stethoscope has been used. The usage time with wired communication can last up to 3 hours. Meanwhile, with Bluetooth-based wireless communication can last for 2.5 hours.

**User Satisfaction Test**

Testing the satisfaction of digital stethoscope users has been carried out with seven health professionals by performing auscultation, as shown in Figure 12. Health professionals, as users of this stethoscope, test the sound quality and features. After conducting the testing, health professionals were asked to assess the system based on three pre-determined objectives, namely needs, convenience, and comfort. The assessment is given with a scale range of 1 – 5. A value of 1 means that health professionals strongly disagree with the statement issued. A value of 5 means that health professionals strongly agree with the information given.



Figure 12. Digital Stethoscope User Satisfaction Test

Table 5. Results of Assessment of Health professionals

Objective	Indicators	Health Professionals							Mean
		A	B	C	D	E	F	G	
Needs	Sound quality	5	5	5	5	4	5	4	4.7
	Recording results	4	4	4	4	5	4	4	4.1
	Visualization	5	5	5	5	5	5	5	5
Convenience	Can be used when PPE level 3	5	5	5	5	5	5	5	5
	Portable	5	5	5	5	5	5	5	5
Comfort	Comfortable to use	4	5	5	5	4	5	5	4.7
	Reduce contamination	5	4	4	4	4	4	5	4.3

The assessment results of seven health professionals in digital stethoscope testing can be seen in Table 5. The average assessment of the three objectives is 4.69. The test results show that all objectives have achieved a very good level of satisfaction. Assessments related to visualization of electrical activity and heart rate received perfect scores from seven health professionals. This feature is proven to have answered the needs of health professionals. Likewise, with the objective of convenience, this digital stethoscope scores perfectly for both indicators, namely, being easy to use with level 3 PPE and portable. This shows that health professionals are delighted with the convenience provided by a digital stethoscope. Indicators of recording results and reducing contamination get good assessment results from health professionals. Both of these indicators still have room for improvement at a later stage. The recording results can later be taken directly to the equipment without having to remove the memory card. This will reduce the chance of being contaminated with the virus. Further testing of virus contamination on the

device also needs to be done to provide confidence to increase the stethoscope user's comfort.

## CONCLUSIONS

The digital stethoscope is made based on three objectives that have been set as a solution to the problems faced by health professionals when examining patients according to technical guidelines for health services during the Covid-19 period. The objective is to meet the needs of health professionals, provide convenience and comfort when using. This digital stethoscope has both wired and wireless communication options that can connect to various audio devices. Another advantage of this stethoscope is that it can display electrical activity and heart rate per minute and can record auscultatory sounds. The recording results can be listened to according to the needs of health professionals. User satisfaction tests have been carried out on seven health professionals who also provide an assessment of the stethoscope that has been made. The assessment is given based on three objectives, namely needs, convenience, and comfort. The average rating is 4.69, which means that health professionals are very satisfied with the digital stethoscope. So it can be concluded that this digital stethoscope has been able to answer the needs of health professionals when conducting patient examinations according to technical guidelines for health services during the Covid-19 period. The auscultation sound output quality, both wired and wireless, can be heard clearly. The visualization and recording features are proven to help the work of health professionals. Health professionals considered that this digital stethoscope was easy and comfortable to use even though they were wearing level 3 PPE and could reduce virus contamination. This digital stethoscope is the right solution and in accordance with the needs and comfort of health professionals during the Covid-19 period.

## REFERENCES

- [1] WHO, "Transmisi SARS-CoV-2: implikasi terhadap kewaspadaan pencegahan infeksi," pp. 1–10, 2020.
- [2] K. RI, "Tentang Novel Coronavirus (Ncov)," *10 Februari 2021*, 2021. .
- [3] WHO, "WHO Coronavirus Disease (COVID-19) Dashboard.," *10 Februari 2021*, 2021. <https://covid19.who.int/>.
- [4] Ikatan Dokter Indonesia, "Standar Perlindungan Dokter di Era Covid-19," 2020.
- [5] BBC News, "Kematian Nakes di Indonesia Akibat Covid-19 Tertinggi di Asia: Seandainya Saya Tidak Disumpah Dokter, Saya Lebih Baik Tidak Memberikan Pelayanan," 2021. <https://www.bbc.com/indonesia/indonesia-58345226>.
- [6] R. S. Vasudevan *et al.*, "Persistent Value of the Stethoscope in the Age of COVID-19," *Am. J. Med.*, vol. 133, no. 10, pp. 1143–1150, 2020, doi: 10.1016/j.amjmed.2020.05.018.
- [7] M. Jiwa, S. Millett, X. Meng, and V. M. Hewitt, "Impact of the Presence of Medical Equipment in Images on Viewers Perceptions of the Trustworthiness of an Individual On-screen," *J. Med. Internet Res.*, vol. 14, no. 4, pp. 1–12, 2012, doi: 10.2196/jmir.1986.
- [8] J. Zhu, Y. Tan, B. Huang, Yu z, and X. H. Gao, "Don't throw the stethoscope away!," *Eur. Heart J.*, vol. 42, no. 1, pp. 1–2, 2020, doi: 10.1093/eurheartj/ehaa343.
- [9] B. Sahiledengle, Y. Tekalegn, K. Bekele, A. Tesemma, and B. J. E. Quisido, "Disinfection of Stethoscope and Non-infrared Thermometer: Practices of Physicians in Ethiopia in the Era of Covid-19," *Risk Manag. Healthc. Policy*, vol. 13, pp. 3245–3257, 2020, doi: 10.2147/RMHP.S289125.
- [10] S. B. Brosnahan, A. H. Jonkman, M. C. Kugler, J. S. Munger, and David A. Kaufman, "COVID-19 and Respiratory System Disorders," no. November, pp. 1–12, 2020, doi: 10.1161/ATVBAHA.120.314515.
- [11] N. Chen *et al.*, "Articles Epidemiological and clinical characteristics of 99 cases of 2019 novel coronavirus pneumonia in Wuhan, China: a descriptive study," *Lancet*, vol. 6736, no. 20, pp. 1–7, 2020, doi: 10.1016/S0140-6736(20)30211-7.
- [12] B. Wang, Y. Wang, and T. Liu, "Characteristics of Pulmonary Auscultation in Patients with 2019 Novel Coronavirus in China," 2020, doi: 10.1159/000509610.
- [13] S. D. Carley, "Towards evidence based emergency medicine: best BETs from the Manchester Royal Infirmary Is emergency department based Towards evidence based emergency medicine: best BETs from the Manchester Royal Infirmary," 2007, doi: 10.1136/emj.2007.053777.
- [14] Y. F. Lau, W. W., and C. P. L., "Are stethoscopes risky in COVID-19?," *Postgrad. Med. J.*, vol. 96, no. 1137, p. 2020, 2020, doi: 10.1136/postgradmedj-2020-138085.
- [15] L. J. Nowak and K. M. Nowak, "Sound differences between electronic and acoustic stethoscopes," *Biomed. Eng. Online*, pp. 1–11, 2018, doi: 10.1186/s12938-018-0540-2.
- [16] S. Leng *et al.*, "The electronic stethoscope," *Biomed. Eng. Online*, pp. 1–37, 2015, doi: 10.1186/s12938-015-0056-y.
- [17] S. Swarup and A. N. Makaryus, "Digital stethoscope: technology update," pp. 29–36, 2018.
- [18] J. P. Tourtier *et al.*, "Auscultation in Flight: Comparison of," *Air Med. J.*, vol. 30, no. 3, pp. 158–160, doi: 10.1016/j.amj.2010.11.009.
- [19] J. Peng, Z. Tao, and Z. Huang, "Risk of Damage to Hearing from Personal Listening Devices in Young Adults," vol. 36, no. 3, pp. 181–185, 2007, doi: 10.2310/7070.2007.0032.
- [20] D. Bodena, Z. Teklemariam, S. Balakrishnan, and T. Tesfa, "Bacterial Contamination of Mobile Phones of Health Professionals in Eastern Ethiopia: Antimicrobial Susceptibility and Associated Factors," *Trop. Med. Health*, vol. 47, no. 1, pp. 1–10, 2019.