

Circularly Polarized Stack-Patch Microstrip Array Antenna for ETS-VIII Applications

Muhammad Fauzan Edy Purnomo

Abstract – By using the H-IIA Launch Vehicle No. 11 from the Tanegashima Space Center, in the south of Kagoshima Prefecture Japan, ETS-VIII (Engineering Test Satellite VIII) has been launched successfully in the end of 2006. The ETS-VIII is one of the largest geostationary S-band satellites in the world to meet future requirements of voice and data communications, broadcasting and global positioning [1].

Backward-looking, there are various types of antennas which developed aiming at ETS-VIII [2]-[5]. A part of the antennas [3] have been experimented outdoor by use of a pseudo-satellite station. Moreover, in order to obtain a good performance antenna to clarify suitably result on frequency characteristic, return loss, and radiation pattern, and also to obtain a simple configuration such as small, light and low profile, a left-handed circularly polarized stack-patch microstrip array antenna is proposed. The antenna was calculated by the Method of Moments using probe-fed pentagonal array antenna as radiating patch and triangular array antenna as parasitic patch with dielectric relative permittivity 2.17 and loss tangent 0.0009.

In this paper, it discuss about the performances of antenna above at $El=48^\circ$ both of calculation and measurement results, the examined of performance beam antenna at low elevation, and the performances of antennas to take in signal from ETS-VIII satellites. The measured results at $El=48^\circ$ agree well with the calculated results of 5 dBic gain, and the 3-dB axial ratio beamwidth of the whole azimuth range about more of 120° for each beam coverage in the conical-cut direction satisfy for ETS-VIII applications.

I. INTRODUCTION

Nowadays, the knowledge of science and technology, especially in the field of mobile satellite communication is developing hugely and rapidly. It is included the development of the ground station antenna as transceiver signal to make a good conducted communication between the satellite and terminal station at the earth. Furthermore, terrestrial mobile communications infrastructure has made deep inherits around the world. Better still at rural areas are getting good coverage in many countries. However, there are still isolated areas and remote area which no good coverage, and some countries do not have coverage yet in towns and cities. On the other hand, satellite mobile communications offers the benefits of true global coverage, reaching into remote areas as well as

populated areas. Moreover, the mobile satellite communication systems were used by a limited number of people due to its relatively expensive cost and also its large earth station size. However, recent advances in digital communication, deployable antenna technologies and hardware implementation technologies have made it possible to reduce the mobile satellite communication cost and terminal hardware size, resulting in expanding the application field [6].

In order to obtain the great advantages of mobile satellite communications, it has been launched satellite mission technologies for testing and researching called ETS-VIII as one of the largest geostationary S-band satellites in 2006 by the Japan Aerospace Exploration Agency (JAXA). Its size will enable direct communications with a geostationary satellite that covers all of Japan (seen Fig. 2), making mobile communications more reliable. Look up to this point, several antennas able to meet these requirements have been investigated [7], are widely available, and include the conical beam antennas [8-16] and satellite-tracking antennas [17-23]. One of the advantages of the former antenna design is that, as the radiation is omnidirectional in the conical-cut direction and the beam is broad in the elevation plane, satellite tracking is not necessary in the elevation direction. However, high gain can not easily be achieved because of the isotropy in the conical-cut direction. In contrast, the beam generated by satellite-tracking systems [18] is always turned towards the satellite position even when the azimuth angle of the mobile station varies. Therefore, such antennas have the possibility to reach a higher gain compared to the conical beam antennas. Every antenna has good antenna characteristics. However the one of the most remarkable disadvantage is the cost, weight and volume. It is expected that the antenna for the next generation of mobile satellite communication is small, thin and high performance [2].

In terms of keeping the stable mobile communications, antenna system gain is required as higher as possible. Furthermore, in terms of mounting the general car roof, compact design with high performance is required. In this reason, gain enhancement of triangular patch antenna is necessary. For getting that purposed, in this paper, a simple stack-patch satellite-tracking left-handed circularly polarized three-element array antenna, whose beams are electrically switched in three azimuth directions, is investigated. The switching is realized by use of a simple on/off feed control rather than by a phase shifter.

Muhammad Fauzan Edy Purnomo is with Department of Electrical Engineering University of Brawijaya
E-mail: mfauzanep@brawijaya.ac.id, mfauzane@yahoo.com

The composition and performance of an antenna designed for ETS-VIII applications are described. Numerical analyses and measurement results are shown and discussing, include of the examined of performance beam antenna at low elevation, and the performances of antennas to take in signal from ETS-VIII satellites.

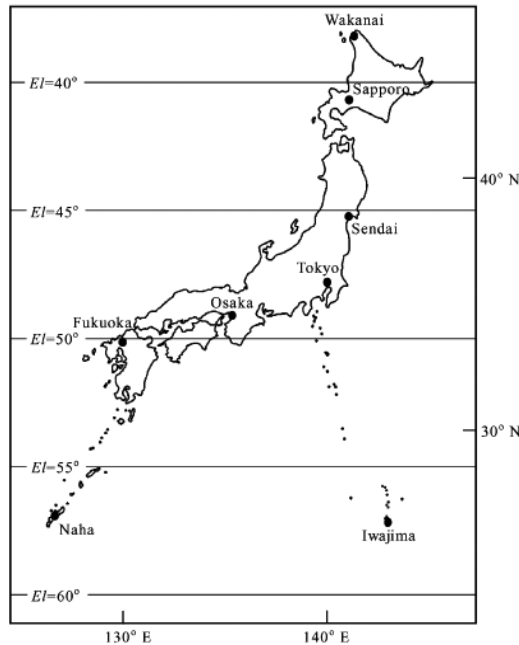

Fig.1. Japan map: elevation angle of beam direction

II. SPECIFICATIONS AND TARGETS

The specifications desired from array antenna for use with mobile satellite communications, in particular aimed at ETS-VIII applications, which are used in this paper, are shown in Table 2. The gain more than 5 dBic (for data rate a hundred kbps) and the axial ratio less than 3 dB of the left-handed circular polarization (LHCP) should be considered to design the antenna. The antenna frequency is set to 2.5025 GHz for the reception antenna.

TABLE 1. SPECIFICATIONS ON THE ANTENNA FOR MOBILE SATELLITE COMMUNICATIONS (ETS-VIII)

Specifications	
Frequency bands	Transmission (Tx) 2655.5 to 2658.0 MHz
	Reception (Rx) 2500.5 to 2503.0 MHz
Polarization	Left-Handed Circular Polarization for both Transmission and Reception
Targets	
Elevation angle (El)	48°(Tokyo)
Azimuth angle (Az)	0° to 360°
Minimum gain	5 dBic
Maximum axial ratio	3 dB
Maximum isolation	20 dB

Regarding services for ETS-VIII applications, a

ground based antenna with 12 dBic gain is necessary to achieve a transmission rate of 1.024Mbps [23]. However, in this research, keeping the previous point in mind, a thin miniaturized antenna designed for a few hundred kbps is analyzed. In this case, the necessary gain over the investigated angular range is set to 6 dBic [2]. In addition, in this research, measurements are assumed to take place in the centre of Tokyo. As a result, the targeted elevation angular range is set between 38° and 58° as the elevation of the geostationary satellite is 48° from this city, and allowing a variation of $\pm 10^\circ$ resulting from the car shaking. The operating frequency is fixed at 2.5025 GHz as receiver.

III. ANTENNA CONFIGURATIONS

For land mobile system aimed at ETS-VIII applications various array antennas have been developed [2-3]. The performances of the antenna [3] have been experimented outdoor by use of a pseudo-satellite station. This research is continuing both of developed antennas, to make an antenna have advantage such as high gain and wide bandwidth like a stack configuration [2], and possibility in dual band frequency operation by a triangular basic shape [3].

The array antenna configuration aimed at ETS-VIII showed in Fig. 4 ($\epsilon_r = 2.17$, loss tangent 0.0009). The antenna is composed of three pentagonal patch antennas, fed instead of three probe feed which directly connected from the ground on the beneath of the construction to radiating patch. In the top of the construction is laid three triangular patches as parasitic elements. The dimension of the construction is 160 mm and 6.4 mm in diameter and height, respectively. Three single patch antennas arranged in 120° difference each other in the azimuth rotation are composed to make the array antenna structure. The distance between two elements by viewing from the central of triangular patch antenna about 0.5λ in order to generate a beam directed as expected. The radiation characteristics of such kind of array configuration were reported in [25], which the array antenna can produce three beams in different azimuth direction ($Az = 0^\circ, 120^\circ, \text{ and } 240^\circ$). Moreover, the distance between tip of antenna element and center point of array composition is set in different length for radiating and parasitic element. By considering the axial ratio performance, their distance is set 8.7 mm and 9.7 mm for fed element and parasitic element, respectively. The proposed array antenna is applied for reception purpose. With this composition, it is expected a possibility of dual band operation antenna design which the reception and transmission antenna can be arranged in one dimension. In addition, the array antenna is mounted by stacked-parasitic patch to enhance the gain and bandwidth. Such model is expected to compensate the loss of the switching circuit that designed on the beneath of the array antenna.

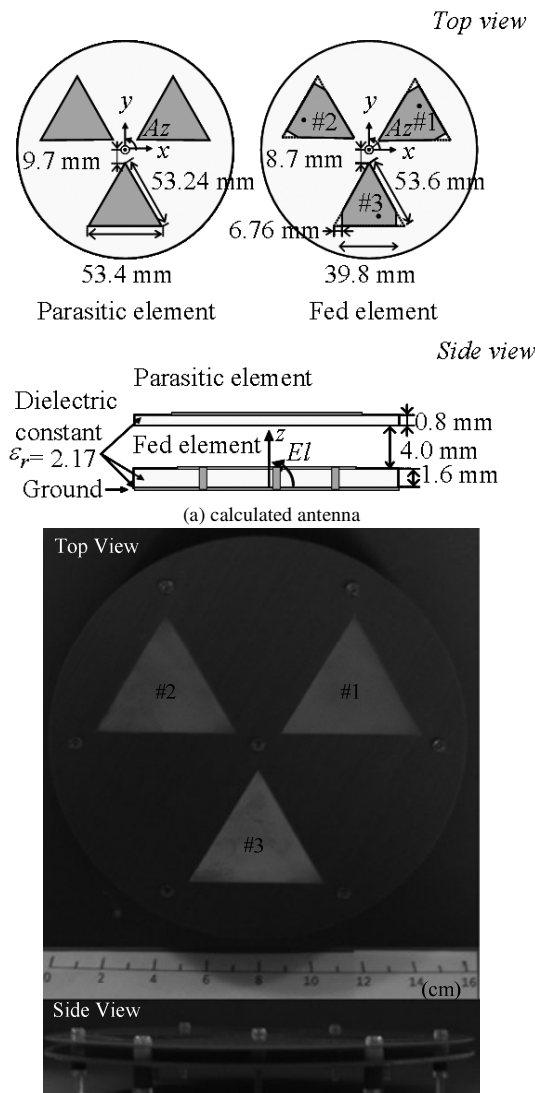

(a) calculated antenna
(b) fabricated antenna
Fig.2. Configurations of array antenna

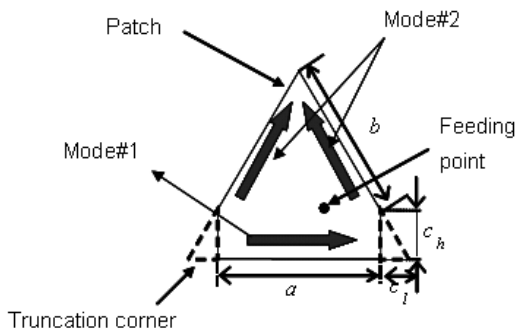

Fig.3 The two orthogonal mode and truncation corner [30]

For a patch antenna, in case the radiating element is loaded with a parasitic element on its top, it is possible to obtain a higher gain and a wider bandwidth by using the multiple resonances generated by the radiating element itself and the parasitic element [24-29]. Fig.2.a. shows the configuration of the triangular patch array antenna with

parasitic element and fabricated antenna is shown in Fig.2.b. The circularly polarized radiation is simply obtained by use of large truncation corner on the driven patch. This truncation corner can control the two orthogonal-modes (i.e., mode #1 and mode #2 in Fig.3) on the patch by setting adjustment the length of c_l and c_h [30]. The area of truncation corner is setting about of $c_l = 6.76$ mm and $c_h = 12.1$ mm which equivalent with adjustment of the length of $a = 39.8$ mm and $b = 39.74$ mm. By used of this proper setting the driven patch which be given the perturbation (i.e. the area of truncation corner) and added parasitic patch (the parameter can be seen in Fig. 2 (a)) make the bandwidth impedance become wider rather than single layer, it caused by the Q of the each mode expanded by the parasitic patch, hence resonant frequency of each mode can be widely separated. Accompany with the feeding location, to match the 50Ω matching input impedance, a 4 mm-air gap is inserted in the space between the radiating and parasitic element. Moreover, the antenna can be fitted to the required frequency by varying a feed location, air gap thickness and antenna dimension. With this consideration the antenna resonates at frequency 2.5025 GHz as a target frequency for reception antenna in ETS-VIII applications. In addition, by setting the isosceles length of the parasitic element is shorter with ratio 0.95 of another sides, good axial ratio CP operation can be obtained [31].

In this configuration, the fabricated antenna looked low profile, small, and lightweight to be mounted on the car-rooftop purpose, and the generated-antenna beam is always directed to the east longitude of 146° where the ETS-VIII satellite is orbited.

IV. PERFORMANCES OF THE ANTENNA

The Method of Moments (MoM) has been chosen in the numerical analysis for its asset of fast calculation. The software used was Ensemble™ version 8 from Ansoft. Owing to the software characteristics, the dielectric substrate and the ground plane are considered to be infinite. The performances are compared with measurements realized using a network analyzer HP 8510C in the radio anechoic chamber of the Graduate School of Science and Technology, Chiba University, Japan. In this section, numerical simulation and experimental results of the proposed antenna are shown, especially for $El=48^\circ$ at Kanto area.

Fig.4 to Fig.8 shows the result for both calculation and measurement, in case of S-parameter, input impedance, axial ratio characteristic, and radiation pattern. The difference between the simulation and measurement that appears in the results is due to the fact that a finite ground is used in the measurement while it is infinite by simulations.

From Fig.4, it can be seen that the measured S11 tends to meet the calculation one. The impedance bandwidth ($S_{11} < -10$ dB) is about 6.93%. The isolation is more than 25 dB which is above the target isolation 20 dB. Fig.5 depicts the input impedance characteristic

of Rx. This figure also shows both of calculation and measurement results are a little bit shifted relative to each others to the lower and higher frequency about of 0.2 %. In this case, the real part of measurement is closed to 50Ω or about $35.90 - j0.95 \Omega$. The mismatch between calculation and measurement impedance is caused by the influence of fabricating error, connector, coaxial cable, aluminum block and plastic screws to support the substrate to be flat [3],[32-39]. Empirically, these are very sensitive to the performance of the antenna, especially the input impedance.

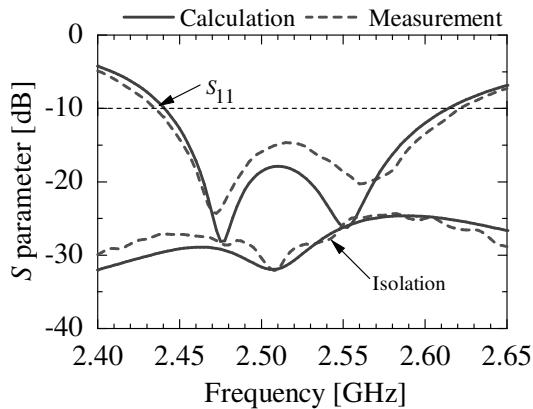

Fig.4. S-parameter

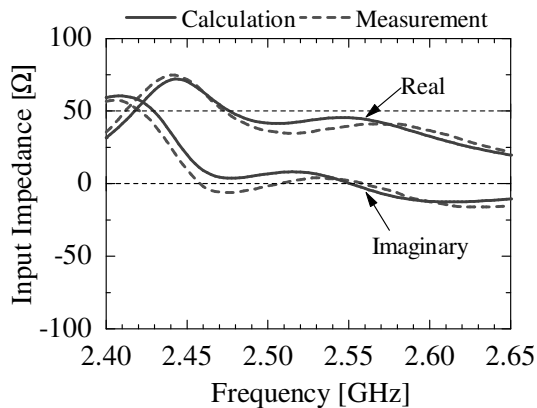

Fig.5. Input impedance

Fig.6 illustrate the measured result of axial ratio is increasing become 1.0 dB at frequency 2.5025 GHz and $El = 48^\circ$. Moreover, the 3 dB axial ratio bandwidth gets about 1.7%. The measurement result is to be worst than the calculation result due to by influence of the way of fabrication and procedure of measurement. In order to be able to match between measurement result of fabricated antenna and the calculation result, the antenna is optimized until the measurement result suits the target for ETS-VIII specifications. Here, the result satisfies the target although little bit decreased.

The axial ratio satisfies the target less than 3 dB and the gain more than 5 dBic at elevation angle $El = 38^\circ - 58^\circ$ as shown in Fig.7. This condition achieved by one of three ports is switched OFF, and the others bias ON. These mechanism make a beam could be directed suit with the target desired.

The beam of the antenna is generated by a simple ON OFF mechanism that consists in one out of three radiating elements is turned off. For that reason, there are three OFF states beam switching mechanism i.e. #1 OFF, #2 OFF, and #3 OFF. By considering the mutual coupling between fed elements, their phases and distances, the beam direction can be varied. Furthermore, the two fed elements theoretically will generate a beam shifted of -90° in the conical-cut direction from the element which is switched OFF. For example, when element #1 which located at $Az=30^\circ$ switched OFF, the beam is directed towards the azimuth angle $Az=-60^\circ$ or 300° [40] (seen Fig.2.a).

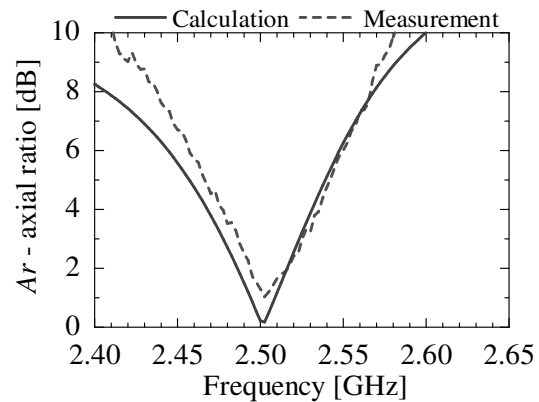

Fig.6. Axial ratio vs frequency

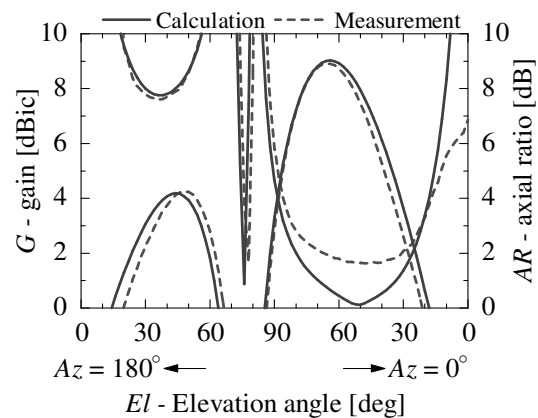
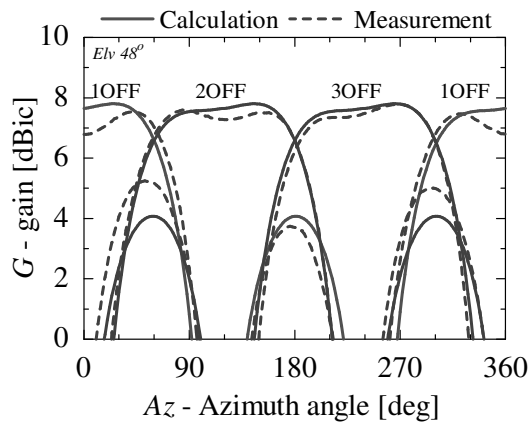
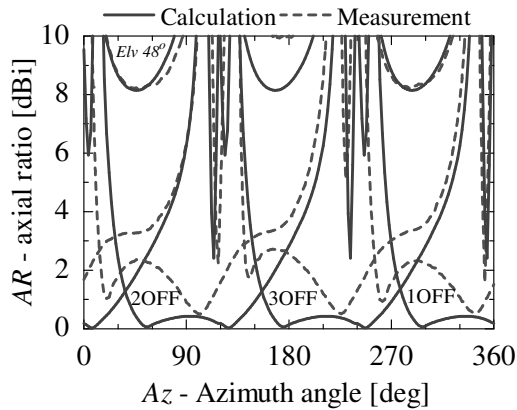

Fig.7. Elevation cut-plane

The measured results of gain and axial ratio characteristics of the beam switching in the azimuth plane are shown in Fig.8. The tendency of the measurement results is same as the calculation ones. The measured results show that at the center beam, the gain of each beam is averaged down in 0.2 - 0.5 dB rather than that of the calculation results. The axial ratio increases for each OFF condition, but the 3-dB axial ratio coverage of the measured result can cover 360° in the conical-cut plane at $El = 48^\circ$. Moreover, the beam is possibly switched at minimum gain 6.3 dBic and although the axial ratio is shifted from the switched point, to cover 360° conical-plane the minimum axial ratio below 3 dB is possibly to be obtained. This elevation is applied at Kanto area.



(a) gain vs azimuth

(b) axial ratio vs azimuth
Fig.8. Conical cut-plane

A. Performances Antenna Beam at Low Elevation

In order to examine the effect of varying elevation toward the performances of antenna beam, both of gain and axial ratio in measurement and calculation results at around azimuth planes. Fig.9 depicts conical cut plane for $El=40^\circ$, and 45° at the frequency $f = 2.5025$ GHz. According to theoretically that if the antenna using a stack or air gap for good matching performances, it is no problems in results, could be operated in normal elevation angle about more than 48° , but when the antenna is operated at low elevation by about below than 48° , the results, especially conical cut-plane performances become worst when the antenna take in the measurement [24-29],[32-39]. If the results compared with the antenna not used a stack or air gap, the results of antenna performance without used of it are better than used it. Here, considering to the theoretically above, it is still normal if the results of measurement, especially at low elevation, in the case Figs.9 (a), could not obtained in a good result. Furthermore, in Figs.9 (a), and (b) are seen that in the case of calculation results i.e. gain above 5 dBic and axial ratio below 3 dB, also the beamwidth coverage for each beam about of 120° could be occurred. But, in the measurement when the elevation little by little increases that gain, axial ratio and beamwidth coverage could be satisfied the target, as

described in Fig.9 (b). The maximum gain is 7.47 dBic and 7.45 dBic by calculation and measurement, respectively. Then, the minimum axial ratio for calculation and measurement is 0.03 dB and 0.22 dB, respectively. Moreover, the calculation beamwidth of gain and axial ratio at elevation 45° are 144° and 153° rather than the measurement beamwidth are 129° and 121° , respectively.

In the case of elevation 40° shown in Fig.9 (a), it strongly affect toward the antenna performance whereas gain, axial ratio, and beamwidth become worst. For example, the maximum gain and the minimum axial ratio for calculation results are 6.58 dBic and 0.23 dB rather than measurement results are 6.62 dBic and 0.23 dB, respectively. Furthermore, the beamwidth of gain and axial ratio calculation results are 135° , and 152° rather than measurement results 129° and 101° , respectively. In addition, that the elevations 40° , and 45° are applied at Sapporo and Sendai area, respectively.

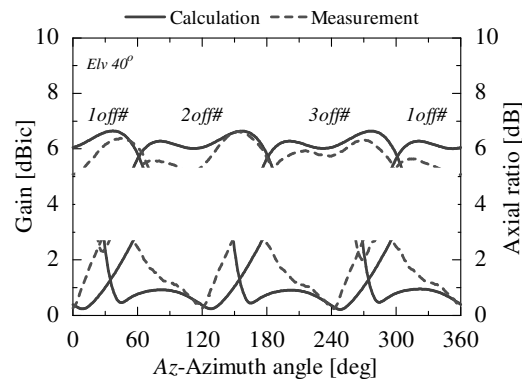
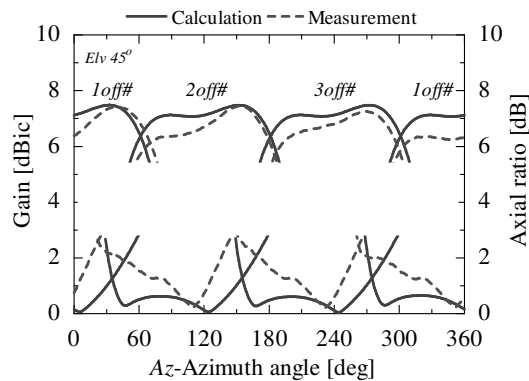
(a) Elevation 40° (b) Elevation 45°
Fig.9. Conical cut-plane in varying elevation

B. The Performances of Antenna Beam in Outdoor Measurement Test

To grasp satellite signal, here, is examined experimentally the beam-antenna performance in the rooftop building as outdoor measurement test. A signal target at frequency 2.5025 GHz which spread by ETS-VIII satellite is test to ensure the antenna able to be received a power level signal from satellite well or not.

To set up the outdoor measurement in rooftop building, four main components are used i.e. array

antenna, GPS unit, spectrum analyzer, and application program [6]. Configuration of the outdoor experiment is depicted in Fig.10.

(i) Array antenna

Geometry antenna is shown in Fig.2 ($\epsilon_r = 2.17$, loss tangent 0.0009). Owing to this antenna is examined to get a power signal level from satellite in different azimuth direction by rotate the rotator of the experiment as manually.

(ii) GPS unit

In this experiment, the GPS is needed only for initial condition to determine a zero reference to ease an acquiring the antenna performance. Here, it is used the GARMIN eTrex 12 Channel GPS and located together on the rotator of the measurement for at the moment time.

(iii) Spectrum analyzer

The type of spectrum analyzer for obtained this experiment is HP-Agilent ESA PSA series (E4403B). It is prepared to read the data that the antenna can grasp the spectrum signals from satellite. The frequency range of this spectrum is 9 kHz – 3.1 GHz.

(iv) Application program

The application program is used to receive the data from spectrum analyzer to remove into laptop to be more convenient for reading and recording the data. This program using a LabVIEW version 8.2 software for Windows Operating system.

The picture of external environment measurement is shown in Fig.11. The configuration of this system can be explained as follow i.e. the stack-patch array antenna is used to grasp signal from satellite and then the signal to be transferred by coaxial cable and GPIB cable into spectrum analyzer and laptop, respectively. To increase the level signal, a RF power amplifier whose maximum gain 23 dB is needed, thus the signal gets a good sensitivity level.

The receiving antenna is adjusted by rotating the rotator step by step toward azimuth angle about 10° until 36 time to complete a full circle rotated 360° and directed to elevation angle around 48° . The result of this measurement is shown in Fig.12, and Fig.13. As described in Fig.11, here, in the narrow range frequency about of 2.502 GHz until 2.503 GHz, some band operations able to be received included the target of frequency at 2.5025 GHz as our target could be confirmed. By use of the formula in equation (1) to calculate signal-to-noise ratio (S/N), the S/N received signal level is about -15.40 dB / 15 kHz still occurred in a good performance condition [41]. The channel bandwidth 15 kHz is obtained by noticed the range frequency which used from 2502.515 MHz until 2.502.530 MHz.

$$\begin{aligned} S/N &= -57.12 \text{ dB/Hz} + 10 \log \text{ channel BW} \quad (10 \log 15 \text{ kHz}) \\ &= -15.40 \text{ dB/15kHz} \end{aligned}$$

.....(1)

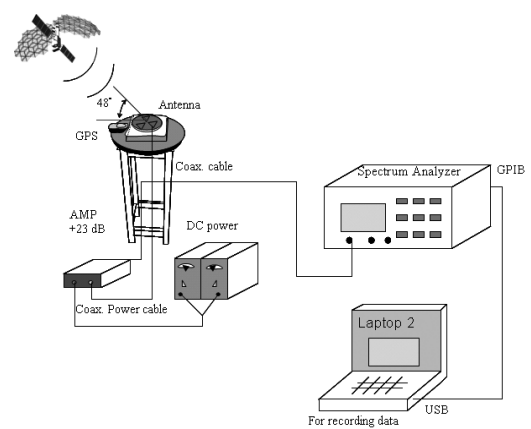

Fig.10. Configuration of the outdoor measurement at roof-top building



Fig.11. The external environment measurement at roof-top building

Furthermore, we can plot the data which received from satellite for each shifting of 10° until completely rotated 360° at frequency 2.5025 GHz as shown in Fig.13 (a), (b), and (c) for 1 OFF, 2OFF and 3 OFF beam characteristics, respectively. Here, to simplify the circumstance, the main antenna beam is directed to Az = 0° , 120° and 240° . The results show good performances and meet the predicted results.

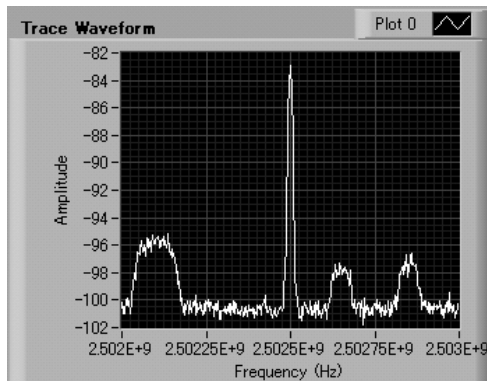

Fig.12. Received spectrum in rooftop building at range frequency 2.502 GHz – 2.503GHz

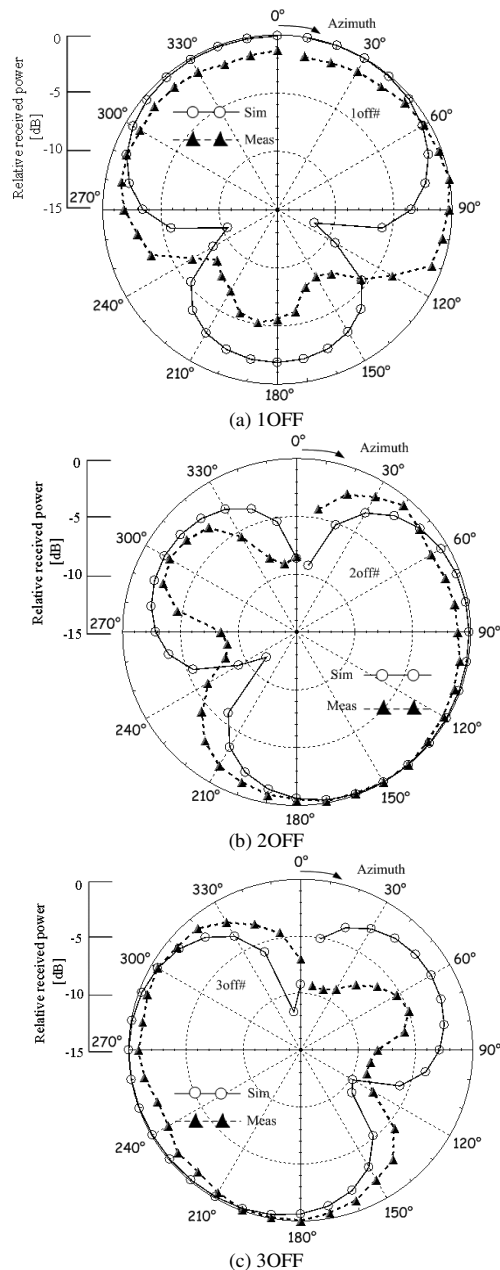

Fig.13. Radiation pattern in azimuth plane of received spectrum measurement at $El = 48^\circ$, $f = 2.5025$ GHz

In the real measurement at roof-top building, the main antenna beam is directed to $Az = 170^\circ$ (satellite direction from Chiba), then the antenna beam characteristics starts to examine. The simulated and measured results appear the similar beam which its direction always into south. The measured result is affected by the error setting in spectrum analyzer, thus the data received probably in mismatch processing condition. Also the effect of the surrounding environment for example reflections from buildings can also be considered to give rise to the occurrence of degradation power received. Moreover, because of the same reason above, a main-lobe beam of measured result is noticed bigger than the simulated results.

V. CONCLUSION

The design of a simple left-handed circular polarized (LHCP) stack-patch microstrip array antenna for mobile satellite communications has been discussed both of calculation and measurement results. The antenna is measured by network analyzer in the indoor measurement and by spectrum analyzer in the outdoor measurement. The measurement results, especially indoor measurement, express that wide impedance bandwidth, low axial ratio, and radiation characteristics are satisfied in the azimuth direction at the target frequency 2.5025 GHz for elevation angle $El = 48^\circ$ at Kanto area. The beam switching characteristics show that gain and axial ratio are more than 5 dBic and less than 3 dB, respectively. In addition, the gain above 5 dBic and the axial ratio below 3 dB can be obtained at elevation angles between $38^\circ - 58^\circ$ as latitude of Japan area.

For elevation 45° at Sendai, both of calculation and measurement results i.e. gain above 5 dBic and axial ratio below 3 dB, also the beamwidth coverage for each beam about of 120° could be occurred. But when the elevation decreased (in case of $El = 40^\circ$ at Sapporo area), the gain and the axial ratio, especially in measurement results are also decreasing, it strongly affected toward antenna beamwidth i.e. both of gain and axial ratio for calculation results are 135° , and 152° rather than measurement results 129° and 101° , respectively.

The outdoor measurement result in the narrow range frequency about of 2.502 GHz until 2.503 GHz, some band operations able to be received included the target of frequency at 2.5025 GHz could be confirmed. The performances antenna beam both of simulated and measured results appear the similar beam which its direction always into south.

The next research will be done to design an optimized stack-patch dual band microstrip array antenna sixth element onboard with optimized circuit switching, and testing in indoor and outdoor experiments for ETS-VIII applications.

VI. ACKNOWLEDGMENT

The authors wish to thank the Strategic Information and Communications R & D Promotion Programme (SCOPE) for Grant-in-Aid for Scientific Research

(Project no. 061203004).

REFERENCES

- [1] JAXA Homepage, "Engineering Test Satellite (ETS- VIII)", http://www.jaxa.jp/projects/sat/ets8/index_e.html
- [2] Delaune D., T. Tanaka, T. Onishi, J. T. Sri Sumantyo, and K. Ito, "A simple satellite-tracking stacked patch array antenna for mobile communications experiments aiming at ETS-VIII applications", *IEE Proc. Microwave Antennas Prop.*, vol. 151, no. 2, pp. 173 - 179, Apr. 2004.
- [3] J. T. Sri Sumantyo, K. Ito, and M. Takahashi, "Dual band circularly polarized equilateral triangular patch array antenna for mobile satellite communications", *IEEE Trans. Ant. Prop.*, vol. 53, pp. 3477-3485, Nov. 2005.
- [4] [T.Tanaka, T.Houzen, M.Takahashi, and K. Ito, "Circularly Polarized Printed Antenna Combining Slots and Patch", *IEICE Trans. Commun.*, VOL.E89—B, 2006
- [5] Delaune D., J. T. Sri Sumantyo, M. Takahashi and K. Ito, "Circularly Polarized Rounded-Off Triangular Microstrip Line Array Antenna", *IEICE Trans. Commun.*, vol. E89-B, no. 4, April 2006
- [6] Basari , Muhammad Fauzan Edy Purnomo , Kazuyuki Saito, Masaharu Takahashi , and Koichi Ito, "Antenna System for ETS-VIII Land Vehicle Communications", *Proceedings of IJSS2008*, Chiba, Japan
- [7] Ito, K., Ohmaru, K., and Konishi, Y., "Planar antennas for satellite reception", *IEEE Trans. Broadcasting*, 1988, 34, (4), pp.457-464
- [8] Ito, K., Daniel, J.-P., and Lenormand, J.-M., "A printed antenna composed of strip dipoles and slots generating circularly polarized conical patterns", *Proc. IEEE Antennas and Propagation Soc. Int. Symp.*, San Jose, USA, 1989, pp. 632-635
- [9] Ito, K., Daniel, J.-P., and Lenormand, J.-M., "Circularly polarized conical-beam antenna composed of strip dipoles and slots", *IEICE Tech. Rep.*, 1989, AP88, (114), pp.87-91
- [10] Naito, M., and Ito, K., "A planar antenna composed of strip dipoles and slots and its application to DBS reception". *Proc. Int. Symp. on Antennas and Propagation*, ISAP '89, Tokyo, Japan, 1989, pp.537-540
- [11] Takahashi, M., Takada, J.-I., Ando, M., and Goto, N., "A slot design for uniform aperture field distribution in single-layered radial line slot antennas", *IEEE Trans. Antennas Propag.*, 1991, 39, (7), pp.954-959
- [12] Takada, J. - I., Tanisho, A. , Ito, K. , and Ando, M., "Circularly polarized conical beam radial line slot antenna", *Electron. Lett.*, 1994,30, (21), pp.1729- 1730
- [13] Takada, J.-I., Ito, K., and Ando, M., "A radial slot antenna radiating circularly polarized conical beam", *Proc. IEEE Antennas and Propagation Soc. Int. Symp.*, Seattle, USA, 1994, pp.1040-1043
- [14] [Takada, J.-I., Yamamoto, T., Ando, M., and Goto, N., "Circularly polarized multibeam radial slot antennas for mobile satellite communication", *Proc. IEEE Antennas and Propagation Soc. Int. Symp.*, Newport Beach, USA, 1995, pp.1430-1433
- [15] Kawakami, H., Sato, G., and Wakabayashi, R., "Research on circularly polarized conical-beam antennas", *IEEE Antennas Propag. Mag.*, 1997, 39, (3), pp.27-39
- [16] Phongcharoenpanich, C., Suriya, S., Lertwiriyaprapa, T., Ngamjanyaporn, P., and Krairiksh, M., "Analysis of circular array of monopole on the ground plane radiating linearly polarized conical beam for wireless LAN applications", *Proc. 5th Int. Symp. on Antennas, Propagation and EM Theory, ISAPE 2000*, Beijing, China, 2000, pp.646-649
- [17] Fujimoto, K., and James, J.R., "Mobile Antenna Systems Handbook", *Artech House*, Boston, London, 1994), Chapter 6
- [18] Yamamoto, S. , Tanaka, K. , Wakana, H. , and Ohmori, S., "An antenna tracking system for land mobile satellite communications systems", *IEICE Tech. Rep.*, 1990, 90, (51), (in Japanese)
- [19] Delaune, D., Tanaka, T. , Onishi, T. , Yoshimura, H. , and Ito, K., "Study of simple single layer patch array antennas for ETS-VIII application", *Proc. Interim Int. Symp. on Antennas and Propagation*, Yokosuka, Japan, 2002, pp.53-56
- [20] Delaune, D., Murayama, Y., Onishi, T., Yoshimura, H., and Ito, K., "On the performances of simple circularly polarized beam-switching 3-element and 4-element patch array antennas for mobile satellite broadcasting/communication". *Proc. IEEE Antennas and Propagation Soc. Int. Symp.*, San Antonio, USA, 2002, pp.732-735
- [21] Preston, S. L. , Thiel, D.V. , Lu, J. W., O'Keefe, S.G., and Bird, T.S., "Electronic beam steering using switched parasitic patch elements", *Electron. Lett.*, 1997, 33, (1), pp.7-8
- [22] Krairiksh, M., Ngamjanyaporn, P., and Kessuwan, C., "A flat fourbeam compact phased array antenna", *IEEE Microw. Wirel. Compon. Lett.*, 2002, 12, (5), pp.184-186
- [23] Jang, J.-H. , Tanaka, M. , and Hamamoto, N., "Portable and deployable antenna for ETS-VIII", *Proc. Interim Int. Symp. on Antennas and Propagation*, Yokosuka, Japan, 2002, pp.49-52
- [24] T. Tanaka, "The radiation characteristics of patch array antenna for mobile satellite communication," Master Graduation Thesis, Feb. 2004.
- [25] R. Garg, P. Bhartia, I. Bahl, and A. Ittipiboon, "Microstrip Antenna Design Handbook", Artech House. London. UK. 2001.
- [26] H.D. Weinschel, "A cylindrical array of circularly polarized microstrip antenna", *IEEE Antennas and Prop. Symposium Digest*, pp. 177-180, Jun. 1975.
- [27] V. Natarajan and D. Chatterjee, "Effects of ground plane shape on performance of probe-fed circularly polarized pentagonal patch antenna", *IEEE Antennas and Prop. Symposium Digest*, pp. 720-723, Jun. 2003.
- [28] Y. Suzuki and T. Chiba, "Computer analysis method for arbitrarily shaped microstrip antenna with multiterminals", *IEEE Trans. on Antennas and Prop.*, vol. AP-32, no.6, pp. 585-590, Jun. 1984.
- [29] H.D. Chen and H.S. Chen, "Compact pentagon microstrip antenna with circular polarization", *Microwave and Optical Tech. Let.*, vol.30, no.6 pp. 370-372, Sep. 2001.
- [30] T. Tanaka, "A study of tracking antenna system for mobile satellite communications, "Doctoral Graduation Dissertation, January 2007.
- [31] [31] Basari, "Development of Simple Switched-Beam Array Antenna System for Mobile Satellite Communications," Master Graduation Thesis, Feb. 2008.
- [32] C.A. Balanis, "Antenna Theory," John Wiley & Sons. USA. 1997.
- [33] Sri Sumantyo, J.T., Ito, K., Delaune, D., Tanaka, T., Onishi, T., and Yoshimura, H., "Numerical analysis of ground plane size effects on patch array antenna characteristics for mobile satellite communications", *Int. J. Numer. Model. Electron. Netw. Devices Fields*, 2005, 18, (2), pp. 95-106
- [34] Otero, M.F., and Rojas, R.G., "Analysis and treatment of edge effects on the radiation pattern of a microstrip patch antenna", *Proc. IEEE AP-S Int. Symp.*, 1995, pp. 1050-1053
- [35] Lier, E., and Jacobsen, K., "Rectangular microstrip patch antennas with infinite and finite ground plane dimensions", *IEEE Trans. Antennas Propag.*, 1983, 31, pp. 978-984
- [36] Delgado, H.J., Williams, J.T., and Long, S.A., "Subtraction of edge-diffracted fields in antenna radiation pattern for simulation of infinite ground plane", *Electron. Lett.*, 1989, 25, pp. 694-696
- [37] Iyer, S.M.V., and Karekar, R.N., "Edge effects for resonance frequency of covered rectangular microstrip patch antenna", *Electron Lett.*, 1991, 27, pp. 1509-1511
- [38] Maci, S., and Borselli, L., "Diffraction at the edge of a truncated grounded dielectric slab", *IEEE Trans. Antennas Propag.*, 1996, 44, pp. 863-873
- [39] Maci, S., Borselli, L., and Cucurachi, A., "Diffraction from a truncated grounded dielectric slab: A comparative full-wave/physical-optics analysis", *IEEE Trans. Antennas Propag.*, 2000, 48, pp. 48-57
- [40] Muhammad Fauzan Edy Purnomo, Basari, Kazuyuki Saito, Masaharu Takahashi , and Koichi Ito, "Developing Antenna for ETS-VIII Applications", *Proceedings of IJSS2008*, Chiba, Japan
- [41] Agilent Technologies, "ESA Spectrum Analyzer User's Guide", Printed in USA, June 2000