

GAS LEAK SOURCE DETECTION ROBOT USING FINITE STATE MACHINE MODEL (FSM)

Agung Arya Adi Nugraha^{1*}, Desti Fitriati²

Informatics Engineering Study Program ^{1,2}
Pancasila University ^{1,2}

agungaryaadinugraha@gmail.com ¹, desti.fitriati@univpancasila.ac.id ²

(*) Corresponding Author

Abstrak

Di kala ini, banyak gas yang beresiko di area sekitar khususnya pada area industri, semacam bahan radiologi serta gas beracun yang dapat mencemari area sekitar juga banyaknya kejadian kebocoran gas. Dari permasalahan tersebut dibuat robot simulasi pendeteksi gas menggunakan model Finite State Machine (FSM), robot dapat membantu pekerjaan manusia dalam hal ini robot membantu mendeteksi kebocoran gas yang jika dihadapkan manusia akan berbahaya. Robot dibuat bertujuan untuk mendeteksi gas yang berada disekitar dan memberikan pemberitahuan jika terjadi kebocoran gas. Robot diuji coba dalam beberapa arena untuk melihat apakah robot dapat melakukan tugas sesuai dengan masukan yang diberikan, uji coba dilakukan sebanyak 40 kali dengan 4 arena yang berbeda, dari 40 pengujian robot dapat melakukan tugas benar 37 kali dan kesalahan 3 kali sehingga didapatkan hasil akurasi sebesar 92,5%. Dengan dibuatnya robot simulasi pendeteksi gas ini diharapkan dapat dikembangkan lagi sebagai robot inspeksi pendeteksi kebocoran gas sebagai sistem peringatan dini.

Kata kunci: Finite State Machine, FSM, Robot, Pendeteksi Gas, Arduino

Abstract

At this time, many gases are at risk in the surrounding area, especially in industrial areas, such as radiological materials and toxic gases that can contaminate the surrounding area as well as the occurrence of gas leaks. From the problem-created gas detection simulation robot using Finite State Machine (FSM) model, the robot can help human work in this case the robot helps detect gas leaks that if faced by humans will be dangerous. The robot was created to detect nearby gases and provide notifications in the event of a gas leak. The robot was tested in several areas to see if the robot could perform the task according to the input given, the trial was conducted 40 times with 4 different arenas, from 40 tests the robot can perform the correct task 37 times and error 3 times so that accuracy results obtained by 92.5%. The creation of this gas detection simulation robot is expected to be developed again as a gas leak detection inspection robot as an early warning system.

Keywords: Finite State Machine, FSM, Robot, Gas Detection, Arduino

INTRODUCTION

In this era, the advancement of robotic technology is very rapidly developing, one of which is widely developed as a gas detection robot. The development of this technology is certainly very helpful for many parties ranging from individuals, large companies, and government institutions, to detect the occurrence of dangerous gas leaks in areas or areas that are difficult to reach by humans (Renaldi et al., 2018). The presence of technology helps facilitate the activities of work done by humans. Robotic technology is also widely used to search an unknown area. Robots are designed and built to help human life, such as helping humans in an unknown and hard-to-reach area of humans.

Robots have advanced technology because they are supported by components such as sensors that serve as interface inputs in robots and are given inputs of artificial intelligence programs implemented inside processors or microcontrollers (Rendyansyah et al., 2019).

At this time, there are many types of gases that are at risk in the surrounding area, especially in industrial areas, such as radiological materials and toxic gases that can contaminate the surrounding area (Gun Gun Maulana, Aris Budiarto, 2020). Usually, the gas can spread in the air due to leaks. The leaking gas that emerged was caused by several factors, such as manufacturing failures, wars, and mining disasters. Gas leaking events can have a major impact on residents and industry, both



injuries and financial problems (Gun Gun Maulana, Aris Budiarto, 2020).

Right now, numerous individuals use ovens with the kind of Liquefied Petroleum Gas (LPG) gas fuel that is prescribed by the public authority to supplant lamp oil utilizing LPG gas. It's just that LPG gas use is still some concern, namely, in the event of a gas leak (Fauziyah et al., 2020). When a gas leak occurs, the gas cannot be directly visible to the human senses because the gaseous substance does not exist, so it is not easily known (Sinaga et al., 2019). The result of gas leaks can cause fires caused by leaks in hoses or gas cylinders (Saptono & Sumbiaganan, 2020).

Research conducted by Lavanna Indanus Ramadha and friends (Ramadhan et al., 2017), researched "LPG Gas Leak Detection System Using Fuzzy Method Implemented with Real-Time Operating System (RTOS)". The data used came from the MQ-6 gas sensor on the device, to detect a gas leak the study used a fuzzy logic algorithm to classify the gas condition. Because of the investigation, the framework had the option to decide different gas spill conditions with exactness up to 100%, The normal execution season of the framework with RTOS (Real-Time Operating System) was 1.8976 ms, while the framework without the RTOS strategy was 1.7304 ms.

The exploration was directed by Wahyu Dirgantara and his companions (Dirgantara et al., 2018), investigating "Early Warning System for Fire Detection in Gas Leaks Using Fuzzy Logic Control". Using data from inputs received by MQ-5 as a gas-detecting sensor and the LM35 sensor used for room temperature detectors ranging from -55°C to 150°C, the study used Fuzzy logic algorithms. As a result of the study, the tool can work with 3 circumstances, namely without gas with a value of 45 in PPM units fixed temperature of 30.49°C, without gas with a value of 70 in PPM units the temperature rises by 31.49°C, and the gas leakage with a value of 1200 in PPM units temperature drops by 28.13.

Based on the shortcomings described above, it takes a robot that can detect gas leaks and can reach the smallest range to detect leaking gas in difficult or dangerous environments if confronted by humans. By this time the industrial revolution was about to enter the artificial intelligence industry 5.0 (Özdemir & Hekim, 2018). Where the development of technology is so rapid that robots can be used as tools that can help humans.

The made robot is intended to have the option to recognize gas spills by searching for gas release focuses, at that point when the fact is discovered it is identified by the robot utilizing a

MQ-2 gas sensor with an Arduino microcontroller. If the density of the gas above the ppm (Part Per Million) value of the specified gas then the LCD screen (Liquid Chrystal Display) displays the detected gas, the buzzer sounds and the fan will light up to reduce the density of the gas at the point of gas leakage.

The robot uses an FSM model. The use of the FSM model consists of a series of states that make decisions. Each state can move to another state if a predetermined condition is met (Jihad et al., 2019). FSM is an abstract machine model consisting of a set of circumstances, an initial state, an input, and a transition function that maps input and the current state to the next state. Implementation of the FSM method applied to robot control and navigation (Tanjung et al., 2018). FSM method is also used as a robot behavior flow regulator (Hartanto et al., 2017). The purpose of this research was to create a simulation robot to detect the source of gas leaks, the data collection technique used is an observation by observing the robot directly to see the changes that occur in gas sensors and robots as a whole as well as literature studies from journals, books, and previous research thesis. Evaluation techniques used are accuracy to know the accuracy of the use of FSM models in robots.

RESEARCH METHODS

In the research of gas leak detection robots using Research and Development (R&D) method is a method that aims to create a product and then test it (Sugiyono, 2008). The products made are gas leak detection robots using FSM models. The flow process of the method can be seen in figure 1

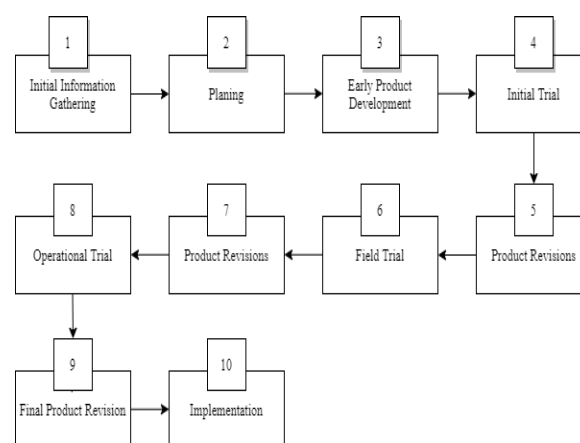

Figure 1. R&D Method Steps

In figure 1 shows the ten steps of the R&D method that will be used in the manufacture of gas leak source detection robots.

Data Collection Techniques

This study using observations and literature studies for the process of collecting data. Observations are used to perform the process of analysis of needs on robot components and programs and collect input and output data on the manufacture of gas leak detection robots, such as regulating the speed of the robot's path, adjusting sensitivity to gas sensors, and adjusting the distance of ultrasonic sensors in robots. Literature studies to gather information related to research that is being conducted from previous research journals.

Microcontroller

The microcontroller is a functional computer system. The microcontroller has a primary processor and a small Random Access Memory (RAM) and for input and output purposes. Like computers, microcontrollers can also perform input commands through a program (Wiyono et al, 2017).

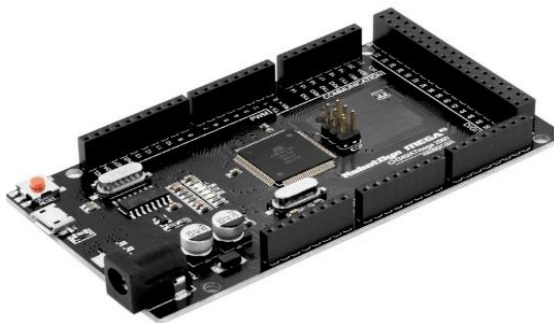

Figure 2. Arduino Microcontroller Mega Type

Figure 2 is an image of an Arduino microcontroller with a mega type. This study using Arduino Mega as a microcontroller to create a gas leak source detection robot.

Sensor

Sensors are electronic components that can detect objects and consist of many kinds, such as ultrasonic sensors, gas sensors, and color sensors, etc (Hermawansa & Kalsum, 2019).



Figure 3. Gas Sensor

In figure 3 is a Gas MQ-2 sensor that serves to detect gas around depending on the type of gas sensor used.

Finite State Machine (FSM)

FSM with the length of Finite State Machine is a model of control system design that shows the tasks or inputs that will be run by the system based on 3 situations, namely: state, event, and action. In programming languages that use procedural paradigms such as in the C programming language, the FSM model is usually applied using switch case or if.. then (Setiawan, 2006).

In this research, the design of the Finite State Machine model on the robot aims to be able to give some commands that will be done by the robot to do its job from out of the room to find and detect the point of a gas leak.

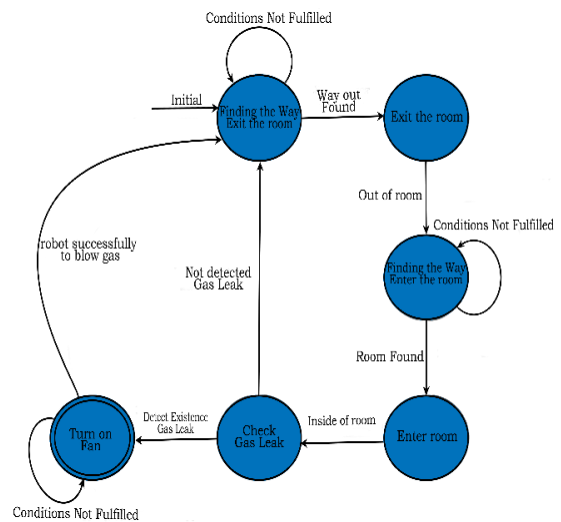

Figure 4. Finite State Machine Model Implementation

Figure 4, shown a diagram of the Finite State Machine model that regulates the movement and action of the robot based on changes in conditions in the arena received by the robot at the time of doing its task. Any changes that occur in the robot's movements are caused by changes that occur based on the detection of sensors in the robot that make the state change.

Block Diagram

In the manufacture of this gas leak source detection robot using the FSM model is expected to run as expected then made a block diagram to see the relationship between components in the robot.

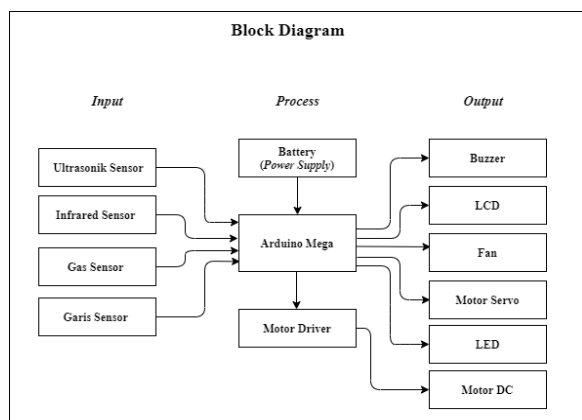

Figure 5. Block Diagram

Figure 5 is an arrangement of gas leak source detection robot block diagrams, in which the image can be input, process, and output. This is where the input comes from the sensor in the robot and then in the process on the microcontroller that is equipped with batteries as a power supply and motor driver as the dc motor drive and produces output based on the input received by the sensor.

Robot Program Design

In the design of robot logic, a flowchart is created to know the workflow of the robot. As well as determining the sensors that work on the robot and the actions performed based on input on certain conditions.

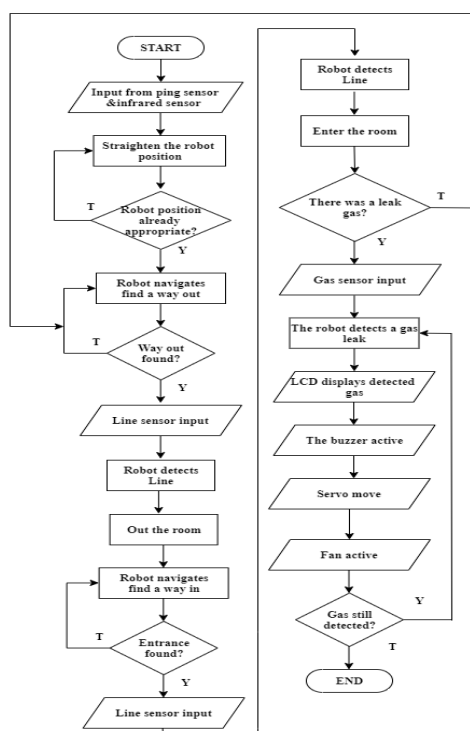

Figure 6. Robot Flowchart

Figure 6 is a program flowchart on gas leak detection robots. In the image can be seen the robot receives input and output from several sensors in the robot, ranging from the robot receives inputs from ping sensors and infrared sensors to receive distance on the track wall and is useful when the robot runs so as not to crash while for line sensors that are to detect the entrance or exit of the trajectory space, on the flowchart can be seen the robot is tasked to find the source of the gas leak point by several times entering the room and also exiting room until it gets a gas leak point and when a gas leak is found, the LCD will display the writing of the detected gas, the buzzer turns on giving a beep sound, and the fan will turn on and blow the detected gas until the density of the gas is reduced and undetectable by the gas sensor.

Build Model

Use of components and functions in gas leak source detection robot.

- The gas detection sensor using the MQ-2 sensor serves as a gas detector in the robot.
- Ultrasonic Ping sensors using HC-SR04 serve as obstruction detectors located on the left, right, and front of the robot.
- An infrared sensor has the same function as an ultrasonic sensor, which avoids obstacles. The robot is used as penhingar if the robot is too tight against the wall on the left and right sides of the robot.
- Line Sensor has a function as a line detector that indicates the robot entering space or exiting space on the trajectory.
- Arduino Mega is used as a microcontroller on robots, serving as a data storage program or command on robots.
- L293D Motor Driver Module serves as a dc motor speed regulator for robot drive.
- Step Down Motor Dc serves as a voltage lower received components from the battery.
- Fan module using L9110 serves to release gas density in the air when the robot detects the presence of gas.
- Gas content monitor using LCD 16x2 I2C function to display gas levels detected by robots.
- Gas markers detected using the Buzzer function to give voice when sensors in the robot detect the presence of a gas that crosses the threshold.
- RGB LED serves as a marker if the robot detects gas exceeding the limit.
- The driver uses a DC motor that serves as a tool to move the position of the robot in this study the author made a robot type of mobile robot.

- Battery as a power supply in robot serves as a power source to turn on components in the robot.
- Servo serves as a left and right fan position drive When detected there is gas exceeding the threshold.
- Software Arduino IDE as software to develop programs from robots.

Track Arena Design

The track simulation arena where the robot will be tested uses a model of this track to find and find the point of a gas leak. The track arena passed by the robot consists of 4 different track arena scenarios. Gas leak source detection robot starts and navigates to find the place where the gas leak is the point where the gas leak occurred

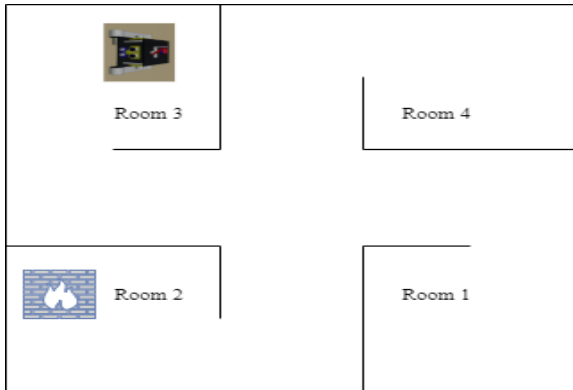

Figure 7. Arena Track Scenario 1

Based on Figure 7 is a scenario of track arena 1 of 4 arenas where robots are tested

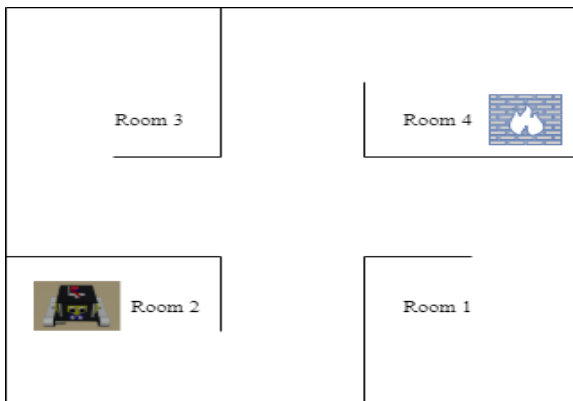

Figure 8. Arena Track Scenario 2

Based on Figure 8 is a scenario of track arena 2 of 4 arenas where robots are tested

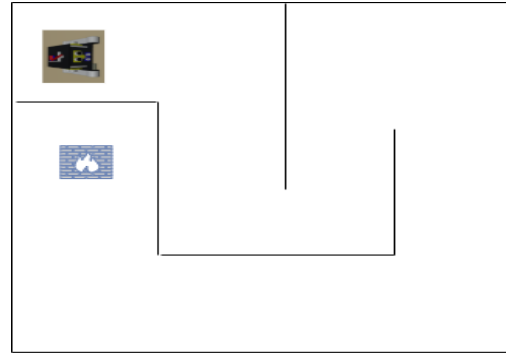

Figure 9. Arena Track Scenario 3

Based on Figure 9 is a scenario of track arena 3 of 4 arenas where robots are tested

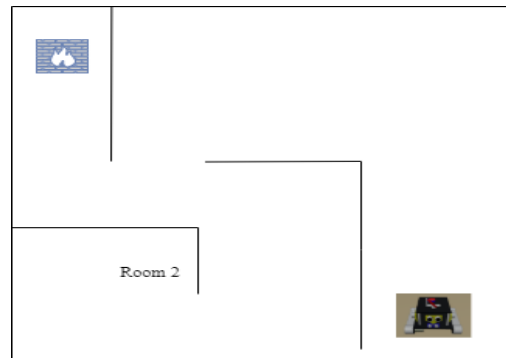

Figure 10. Arena Track Scenario 4

Based on Figure 10 is a scenario of track arena 4 of 4 arenas where robots are tested

Accuracy

To obtain the accuracy value, the author observed the robot on the track arena that will be used to simulate the movement or displacement that will be performed by this Gas Leak Source Detection Robot. The Track Arena in question is a Robot Arena track to find the source of the gas leak point in the room in the track arena.

Then look if the robot can do its job correctly or not, by observing the robot running on the track and looking for the source of the gas leak, and seeing how many times the robot failed and succeeded in detecting gas in the track arena. Then the calculation is done by dividing all the number of experiments carried out by the number of robots performing tasks correctly, then obtained the formula of calculating the accuracy of the Robot as follows:

$$\text{Accuracy} = \frac{\sum A}{B} \times 100\% \dots\dots\dots (1)$$

Where:

A = Number of Robots performing commands correctly.

B = Number of Authors conducting experiments.



RESULTS AND DISCUSSION

In the research conducted the robot was tested in several arenas trajectory. The track arena consists of 4 test scenarios, each of which is tested 10 times, a total of 40 times the overall test of all track arena scenarios.

When the robot is ignited then the robot starts running on the track arena and looks for the source point of the gas leak, in this study the source of the gas used comes from the gas match and uses the C programming language as a programming language supported by the Arduino Microcontroller on the gas leak source detection robot.

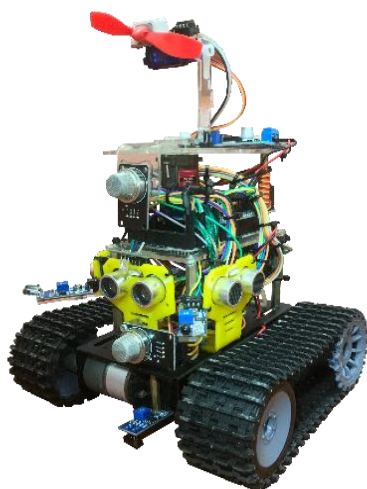

Figure 11. Robot Display

Figure 11 is a display of a gas leak source detection robot that has been arranged into one component as seen in the picture. This robot is a simulation robot to detect the source of gas leaks.

Table 1. Gas Sensor Testing

No.	Distance	Time	Gas (PPM)
1	1-cm	1-second	329
	1-cm	2- second	494
	1-cm	3- second	691
	1-cm	4- second	736
	1-cm	5- second	851
2	2-cm	1- second	212
	2-cm	2- second	255
	2-cm	3- second	451
	2-cm	4- second	539
	2-cm	5- second	707
3	3-cm	1- second	121
	3-cm	2- second	125
	3-cm	3- second	202
	3-cm	4- second	251
	3-cm	5- second	314

Table 1 is a test of the gas sensor used in the Gas Leak Source Detection Robot, by comparing the distance, time, and amount of PPM of gas received

by the sensor by looking at the Arduino IDE serial monitor, testing of this gas sensor the source of the gas used comes from a gas match.

Table 2. Infrared Sensor Testing

Distance (cm)	Infrared Sensor	
	Left Sensor	Right Sensor
1	Detected	Detected
2	Detected	Detected
3	Detected	Detected
4	Detected	Detected
5	Detected	Detected
6	Detected	Detected
7	Detected	Detected
8	Not Detected	Not Detected
9	Not Detected	Not Detected
10	Not Detected	Not Detected

In Table 2, testing on the infrared sensor with a distance of 1 to 10 cm. An infrared sensor can be adjusted the sensitivity of distance measurement using the potentiometer on the sensor. In this research, the infrared sensor used can detect objects left and right infrared sensor can detect a maximum of 7 cm to be used on robots.

Table 3. Ultrasonic Sensor Testing

Real Distance (cm)	Ultrasonic	
	Sensor Distance (cm)	%Error
2	2	0%
3	3	0%
4	4	0%
5	5	0%
6	6	0%
7	7	0%
8	8	0%
9	9	0%
10	10	0%
11	11	0%
12	12	0%
13	13	0%
14	14	0%
15	15	0%
16	16	0%
17	17	0%
18	18	0%
19	19	0%
20	20	0%
21	21	0%
22	22	0%
Average Error		0

- Error percentage:

$$\%Error = \frac{Real\ Distance - Sensor\ Dintance}{Real\ Distance} \times 100\% \dots (2)$$

- Average Error:

$$\%Average\ Error = \frac{Total\ Amount\ \%Error}{Total\ \%Error} \dots (3)$$



In Table 3, ultrasonic sensor testing has conducted a comparison of the distance between the original distance and the distance measured by the ultrasonic sensor, to find out the difference in the distance on the sensor and the size of the meter.

Table 4. Line Sensor Testing

No.	Line Color	Analog Value Read on Sensor	Digital Value Read on Sensor
1	Black	740	1
2	White	55	0

Table 4 is the result of testing of line sensors that detect black and white lines, can be concluded if the analog value that reads smaller means that the color detected is white or lighter while if the value is high it detects black or dark color. Analog values that are generated are not always fixed or capricious, in tests taken values that appear more than 3 times at the time of testing. For digital values produced by the sensor is only a value of 0 and 1 only or high and low.

Table 5. Overall FSM Model State Testing

Testing Code	Scenario Name			
	Scenario 1	Scenario 2	Scenario 3	Scenario 4
U-1	Success	Failed	Success	Success
U-2	Success	Success	Success	Success
U-3	Success	Success	Success	Success
U-4	Success	Success	Success	Success
U-5	Success	Success	Success	Success
U-6	Success	Success	Success	Failed
U-7	Success	Success	Success	Success
U-8	Failed	Success	Success	Success
U-9	Success	Success	Success	Success
U-10	Success	Success	Success	Success
Success	9	9	10	9
Failed	1	1	0	1
Total Accuracy	92,5%.			

Table 5 is a table that shows the results of tests conducted on the robot as many as 40 times with the results of 3 errors and 37 times successfully to detect the presence of gas leaks on the track at the time of testing conducted

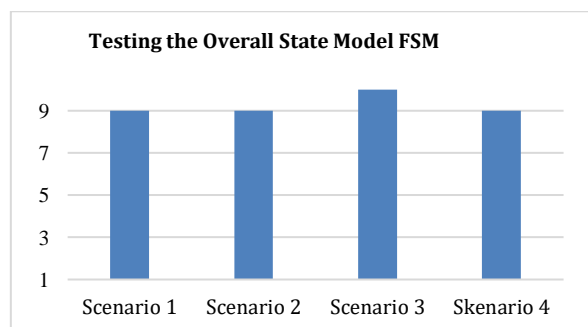

Figure 12. Overall Testing State FSM Model

Figure 12 is the diagram for the overall test of the FSM model state designed, a trial was conducted 40 times with 4 kinds of arena scenarios, each arena scenario was tested 10 times, namely scenario 1, scenario2, scenario 3, and scenario 4. In scenario 1 the robot can perform the task correctly 9 times and fail 1 time, then for scenario 2 the robot can perform the correct task 9 times and fail 1 time, while for scenario 3 the robot can perform the correct task 10 times without failure and the last one in scenario 4 the robot can perform the correct command as many as 9 times and get 1 failure.

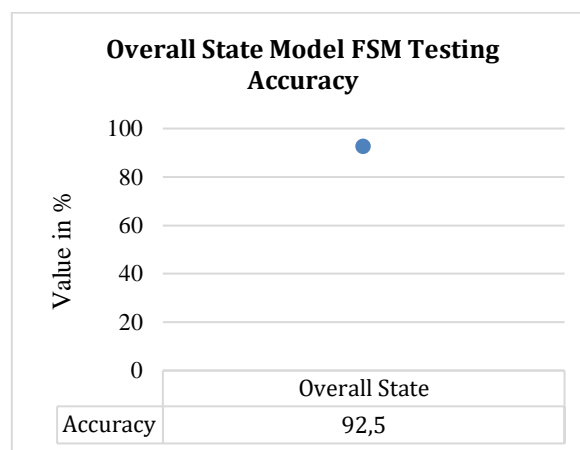

Figure 13. Accuracy of Overall Testing State FSM Model

In Figure 13 is the overall state test on the FSM model designed from the overall test as much as 40 times from 4 types of track arenas namely scenario 1, scenario 2, scenario 3, and scenario 4, which obtained an accuracy score of 92.5%.

CONCLUSIONS AND SUGGESTIONS

Conclusion

Research and development of Gas Leak Source Detection Robot Using Finite State Machine (FSM) Model. With the making of robots in this study, it is expected that robots, if developed, can be useful for many people because they can help in detecting gases, the types of gases that exist are very many of them are toxic so that it is very dangerous if inhaled by humans and this robot also if developed can be used as a leak inspection robot in the oil and gas industry so that it can know more quickly if there is a gas leak as a step anticipation fire and accident due to undetectable gas leaks that cause gas to stick out in the air so much that the gas mixes with the sanyawa that is in the air and causes fire. Gas detection performed on robots is influenced by the surrounding state due to volatile

gases in the air, as well as the quality of the type of gas sensor used.

Suggestion

To be further developed in terms of components to be able to detect gases better and develop algorithms used and provide enough power if the robot uses many components so that there is no weak voltage when the robot is move.

REFERENCE

- Dirgantara, W. T., Suyono, H., & Setyawati, O. (2018). Sistem Peringatan Dini untuk Deteksi Kebakaran pada Kebocoran Gas Menggunakan Fuzzy Logic Control. *Jurnal EECCIS*, 11(1), 27–32.
- Fauziyah, I. N., Harliana, H., & Gigih, M. B. (2020). Rancang Bangun Alat Pendeteksi Kebocoran Gas LPG Menggunakan Sensor MQ-6 Berbasis Arduino. *Jurnal Ilmiah Intech: Information Technology Journal of UMUS*, 2(01). <https://doi.org/10.46772/intech.v2i01.185>
- Gun Gun Maulana, Aris Budiarto, V. S. (2020). Robot Pendeteksi Gas Beracun dengan Menggunakan Metode Multi Layer Perceptron. *Ensiklopedia of Jurnal, Vol 2, No(2)*, 144–154.
- Hartanto, M. I., Mutijarsa, K., & Adiprawita, W. (2017). Sistem Koordinasi Berbasis Perilaku pada Robot Sepak Bola. *5th Indonesian Symposium on Robotic Systems and Control*, pp.219-223.
- Hermawansa, H., & Kalsum, T. U. (2019). Analisis Kinerja Sensor Pada Robot Pendeteksi Kotoran Debu Dan Air. *ILKOM Jurnal Ilmiah*, 11(1), 53–58. <https://doi.org/10.33096/ilkom.v11i1.405.53-58>
- Jihad, M. H., Andromeda, T., & Sudjadi, S. (2019). Aplikasi Pengendalian Arm Manipulator 4 Dof Menggunakan Algoritma Finite State Machine Sebagai Pemindah Sayuran Pascapanen Terozonisasi. *Transient*, 7(3), 782. <https://doi.org/10.14710/transient.7.3.782-788>
- Özdemir, V., & Hekim, N. (2018). Birth of Industry 5.0: Making Sense of Big Data with Artificial Intelligence, “the Internet of Things” and Next-Generation Technology Policy. *OMICS A Journal of Integrative Biology*, 22(1), 65–76. <https://doi.org/10.1089/omi.2017.0194>
- Ramadhan, L. I., Syaury, D., & Prasetyo, B. H. (2017). Sistem Pendeteksi Kebocoran Gas LPG Menggunakan Metode Fuzzy yang Diimplementasikan dengan Real Time Operating System (RTOS). *Jurnal Pengembangan Teknologi Informasi Dan Ilmu Komputer (J-PTIHK) Universitas Brawijaya*, 1(11), 1206–1213.
- Renaldi, B., Wibowo, S. A., Gas, R. P., Tsukamoto, M. F., & Uno, A. (2018). Rancang Bangun Robot SAR Sebagai Pendeteksi Gas Beracun Pra Evakuasi. 4(1), 247–255.
- Rendyansyah, R., Prasetyo, A. P. P., & Exaudi, K. (2019). Implementasi Fuzzy Logic dan Trajectory Pada Manipulator Mobile Robot Untuk Deteksi Kebocoran Gas. *Jurnal Rekayasa ElektriKa*, 15(1). <https://doi.org/10.17529/jre.v15i1.12373>
- Saptono, M. P., & Sumbiaganan, A. (2020). Lpg Gas Leakage Prototype Based on Atmega328 and Lcd Microcontroller As Information Media. *Electro Luceat*, 6(1), 82–92. <https://doi.org/10.32531/jelekn.v6i1.200>
- Setiawan, I. (2006). Perancangan Software Embedded System Berbasis FSM. *Jurnal Teknik Elektro*, 1–2.
- Sinaga, F. S., Lase, B. K., Putta, P. S., Partiwin, J., & Azmi, F. (2019). Implementasi Fuzzy Logic Tsukamoto Untuk Deteksi Gas Lpg Berbasis Arduino. *Jurnal Mantik Penusa*, 3(1), 51–55.
- Sugiyono. (2008). *Metode penelitian pendidikan:(pendekatan kuantitatif, kualitatif dan R & D)*. Alfabeta.
- Tanjung, R., Fauzi, A., Setyawan, G. E., & Kurniawan, W. (2018). Penggunaan Finite State Machine Untuk Navigasi dan Kendali Ar . Drone Quadcopter Menggunakan Microsoft Kinect. *Jurnal Pengembangan Teknologi Informasi Dan Ilmu Komputer (J-PTIHK)*, 2(12), 7427–7431.
- Wiyono, A., Sudrajat, A., Rahmah, F., & Darusalam, U. (2017). Rancang Bangun Sistem Deteksi Dan Pengaman Kebocoran Gas Berbasis Algoritma Bahasa C Dengan Menggunakan Sensor Mq-6. *Konferensi Nasional Teknologi Informasi Dan Komputer, I*, 78–85.