

# Voltmeter Design Based on ADS1115 and Arduino Uno for DC Resistivity Measurement

Risky Martin Antosia<sup>#</sup>

Geophysical Engineering Department, Institut Teknologi Sumatera  
Jalan Terusan Ryacudu, Way Hui, Jati Agung, Kabupaten Lampung Selatan, Lampung, Indonesia  
<sup>#</sup>martin.antosia@tg.itera.ac.id

---

---

## Abstract

One part of the geoelectric method is DC (Direct Current) resistivity measurement. Physical parameters measured by the system are the current and potential difference. From these two parameters, the resistance value is obtained based on Ohm's law. Based on the current-potential electrodes configuration in the DC resistivity measurement, there is the possibility of contact between the potential-current electrodes and also the position of the potential electrodes that can be exchanged. Thus, an auto-range Voltmeter is needed which can measure the potential difference with the order of mV up to hundreds of volts and can measure negative potential difference value (reversed polarity). This research aims to build a Voltmeter prototype using ADS1115 (namely ADC with 16-bit resolution) and Arduino Uno, which can be applied in DC resistivity measurement. In this system, there is internal resistance and switch. The internal resistance is around 2.4 M $\Omega$ , arranged into a voltage divider circuit to be able to measure the maximum potential input around 1,600 V. The switch function is to set the measurement mode (as auto-range), which is set by Arduino Uno. Furthermore, ADS1115 uses a differential measurement method to be able to measure a negative potential difference. Based on the results of tests on several resistor components with an adjustable voltage source, the Voltmeter is good at measuring the potential difference in resistor values below 10 K $\Omega$  with a confidence level of around 97%.

**Keywords:** DC resistivity, Voltmeter, auto-range, ADS1115, Arduino Uno

## Abstrak

Salah satu bagian dari metode geolistrik adalah pengukuran resistivitas DC (Direct Current). Parameter fisis yang diukur oleh sistem adalah arus dan beda potensial. Dari kedua parameter tersebut, nilai resistansi diperoleh berdasarkan hukum Ohm. Berdasarkan konfigurasi elektroda arus-potensial pada pengukuran resistivitas DC, ada kemungkinan terjadi kontak antara elektroda arus-potensial dan juga posisi elektroda potensial dapat tertukar. Maka diperlukan suatu Voltmeter auto-range yang dapat mengukur beda potensial dengan orde mV hingga ratusan volt dan dapat mengukur nilai beda potensial negatif (reversed polarity). Penelitian ini bertujuan untuk membuat sebuah prototype Voltmeter dengan menggunakan ADS1115 (yaitu ADC dengan resolusi 16-bit) dan Arduino Uno, yang dapat diaplikasikan dalam pengukuran resistivitas DC. Dalam sistem tersebut terdapat internal resistansi dan Switch. Internal resistansi yang digunakan sekitar 2,4 M $\Omega$ , yang disusun menjadi rangkaian pembagi tegangan agar dapat mengukur input potensial maksimal sekitar 1.600 V. Switch berfungsi untuk mengatur mode pengukuran (sebagai auto-range), yang diatur oleh Arduino Uno. Selanjutnya ADS1115 menggunakan metode pengukuran differensial agar dapat mengukur nilai beda potensial negatif. Maka berdasarkan hasil pengujian pada beberapa komponen resistor dengan sumber tegangan yang dapat diatur keluarannya, Voltmeter baik dalam mengukur beda potensial pada nilai resistor di bawah 10 K $\Omega$  dengan tingkat kepercayaan sekitar 97%.

**Kata kunci:** resistivitas DC, Voltmeter, auto-range, ADS1115, Arduino Uno

---

---

## I. INTRODUCTION

The geoelectric method is one of the methods in the geophysical field that is widely used for the exploration of natural resources [1]-[3]. One part of the method is DC (Direct Current) resistivity

measurement. Based on [4]-[6], in general, the main DC resistivity measurement system consists of a power source, Amperemeter, and Voltmeter. The measurement is carried out by a power source employing electrical energy into the earth through two current electrodes (A and B electrodes), then

the Amperemeter measures the current flowing at the electrodes and the Voltmeter measures the potential difference response through two potential electrodes (M and N electrodes) with the configuration shown in Figure 1. In this configuration, there are two physical parameters measured by the system, the current value ( $I$ ), and the potential difference ( $V$ ). Referring to Ohm's law, the resistance value ( $R$ ) will be obtained with the following formula:

$$R = \frac{V}{I} \quad (1)$$

The resistance from (1) represents the resistance of material/rock in the earth's layer which is limited in measurement according to Figure 1. Resistance is directly proportional to resistivity, so knowing the resistance value will give an idea of the magnitude of the resistivity value.

Electrical energy applied to the earth can be either a current source or a voltage source. The development of current source systems has been carried out by [4] and [7]. Whereas [5] and [6] developed a voltage source system. Research of [7] only focuses on developing the electrical source (constant current source), while [4]-[6] develop a complete system of DC resistivity measurement. Amperemeter is in the form of a current sensor and Voltmeter uses voltage sensors in the form of ADC (Analog to Digital Converter). In these studies, the Voltmeter uses ADC with a 10-bit resolution, which is an integrated ADC with a microcontroller. Reference [4] explained that the change in each ADC bit is worth about 4.8 mV (or written 4.8 millivolts) with a 5 V reference voltage, so the maximum potential difference value that can be measured is 5 V as well.

Looking back at Figure 1, two possibilities will occur in the configuration assembly:

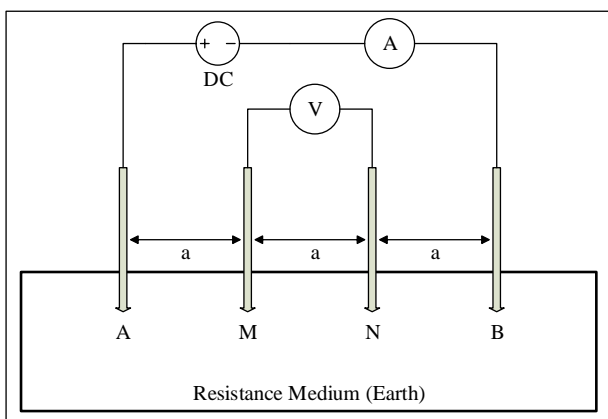

Figure 1. Example of current-potential configuration (modified from [1]-[4])

1. Short-circuit between current and potential electrodes. This will cause the Voltmeter to measure the potential difference of more than 5 volts and will cause the Voltmeter and its microcontroller to be damaged. Even a similar device that has been circulating on the market, the output voltage can reach 500 V [8].
2. The position of the electrodes of M and N are switched. The position of the exchanged potential electrodes (with a fixed position of current electrodes) will cause the negative reading of the potential difference.

Thus the system needs an auto-range Voltmeter, which is a Voltmeter that can measure potential difference values with a wide measurement range, order mV up to hundreds of volts, and can also measure the potential difference that is a negative value (reversed polarity). This research aims to build a prototype Voltmeter using ADS1115 (namely ADC with 16-bit resolution) and Arduino Uno, which can be applied in DC resistivity measurement.

## II. RESEARCH METHOD

This research consists of two steps design methods which are hardware design and Arduino Uno programming.

### A. Hardware

The ADS1115 component in method [9] can measure battery voltages up to 20 V using a voltage divider circuit. The circuit becomes the internal resistance of the Voltmeter. According to [10], a Voltmeter must have a very large internal resistance if it is used to measure the potential difference of a material resistance in an electrical circuit as in Figure 2.

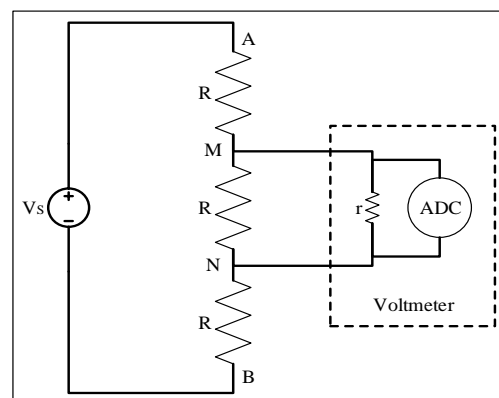

Figure 2. The equivalent electrical circuit for the configuration example in Figure 1 ( $R$  is material resistance)

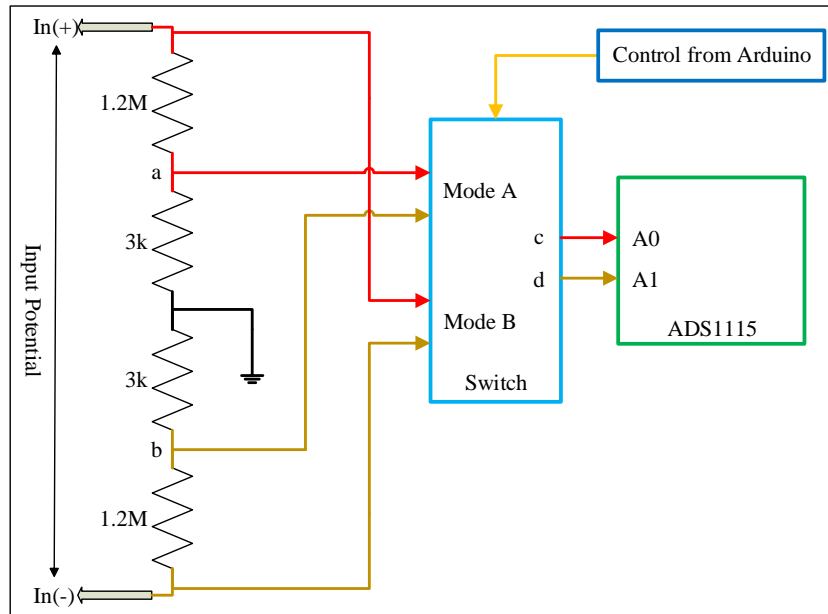

Figure 3. Auto-range and reversed polarity schematic

Based on Ohm's law, the potential difference at MN points is

$$V_{MN} = i_{MN}R \quad (2)$$

where  $V_{MN}$  and  $i_{MN}$  are the potential difference at the MN points and the current flowing at that point. Before installing the Voltmeter in the circuit of Figure 2, the current flowing at the MN points is equal to the total current flowing in the circuit as follows

$$\begin{aligned} i_{total} &= \frac{V_S}{3R} \\ i_{MN} &= \frac{V_S}{3R} \end{aligned} \quad (3)$$

Thus the relationship between (2) and (3) is

$$V_{MN} = \frac{V_S}{3} \quad (4)$$

where  $V_S$  and  $i_{total}$  are the voltage source and the total current flowing in the circuit. Then after installing the Voltmeter (with its inner resistance  $r$ ) in the circuit of Figure 2, the current flowing at that point is the difference in total current with the current flowing at the Voltmeter is

$$i_{total} = \frac{V_S(R+r)}{R(2R+3r)} \quad (5)$$

and

$$i_{MN} = i_{total} - i_{voltmeter} \quad (6)$$

Based on Kirchhoff's Voltage Law (KVL),

$$V_{Voltmeter} = V_{MN} \quad (7)$$

with  $V_{Voltmeter}$  and  $i_{voltmeter}$  are the potential difference and the current flowing at the Voltmeter. Thus (6) can be written as follows

$$i_{MN} = \frac{V_S(R+r)}{R(2R+3r)} - \frac{V_{MN}}{r} \quad (8)$$

There is a relationship between (2) and (8), so it is obtained the following equation

$$i_{MN} = \frac{r}{R(2R+3r)} V_S \quad (9)$$

The measured value of the Voltmeter in (2) must be close to the calculated value (before installing the Voltmeter). If given a limit that the approaching value which measured by the Voltmeter is 90% of the calculated value, the potential difference value at the MN points based on (4) becomes

$$V_{MN} = \left(\frac{V_S}{3}\right) 90\% = 0.3V_S \quad (10)$$

Then (10) is substituted in (2), the following equation is obtained

$$i_{MN} = \frac{0.3V_S}{R} \quad (11)$$

Then (11) is substituted in (9), so that it is obtained the following equation

$$r = 6R \quad (12)$$

From the derivation result of (12) and refer to Figure 2, the minimum value of internal resistance ( $r$ ) of a Voltmeter is 6 times greater than the material resistance that will be measured by its potential difference value. According to the example of the resistivity value of [1], there is a material/rock with a resistivity value of 10,000  $\Omega\text{m}$ . Based on Ohm's law, the relationship of resistivity ( $\rho$ ) and resistance is as follows

$$\rho = \left(\frac{A}{L}\right) R \quad (13)$$

with  $A$  and  $L$  are the cross-sectional area and length of material. If the dimensions of the material are one square meter and one meter long; and referring to (13), the material resistance shall be  $10,000 \Omega$  (or  $10 \text{ K}\Omega$  can be written). Regarding (12), the minimum value of internal resistance in a Voltmeter of  $60,000 \Omega$  (or  $60 \text{ K}\Omega$  can be written) is required. In method [9], the Voltmeter design cannot be used to measure the potential difference values of a large material resistance in an electrical circuit.

The use of the ADS1115 component as a Voltmeter is also found in method [11], the ADC can measure the battery voltage using differential measurement to measure negative voltage if reversed polarity. Therefore, to get an auto-range measurement of potential difference up to hundreds of volts and can also be reversed polarity, it is necessary to modify the methods [9] and [11] as shown in Figure 3.

The Voltmeter design in this study uses an inner resistance of around  $2.4 \text{ M}\Omega$ . This value is obtained from the sum of all resistor components between the input potential (see Figure 3). The use of resistance with this value is intended so that the approaching value can be better in measuring the potential difference of material resistance. For example measuring the potential difference in material resistance of  $10 \text{ K}\Omega$  with the configuration as shown in Figure 2 (in the above explanation that appropriate to (12) with the Voltmeter internal resistance of 6 times greater than the value of material resistance, a potential difference measurement approaching of 90% is obtained). So by looking at (3), the current flowing through the material resistance ( $R$ ) is equal to

$$i_{MN} = \frac{V_S}{3} 10^{-4} \quad (14)$$

Then the calculation of the current flowing at the material resistance according (9), the material resistance measured by the Voltmeter which has an inner resistance ( $r$ ) of  $2.4 \text{ M}\Omega$  is

$$i_{MN} = \frac{V_S}{3} 10^{-4} (99.72\%) \quad (15)$$

Thus, by substituting calculation (15) in (2), the potential difference value in the material resistance is

$$V_{MN} = \frac{V_S}{3} (99.72\%) \quad (16)$$

Judging from the result of (16), the potential difference value measured by the Voltmeter is 99.72% from the results of calculations in (4).

The Switch function in Figure 3 as an auto-range measurement. The reference voltage used by the ADC is 5 volts. The reference voltage is uncertain at 5 V, usually around 4.9 V. So in Mode A, the

maximum input potential is set at 4 V (the value is chosen to make it easier to do calculations), so that in this mode the measurement range is below 4 V. Whereas in Mode B, the input potential enters the voltage divider circuit. By giving a potential difference limit at a-b points ( $V_{ab}$ ) of 4 V, the maximum potential input value ( $V_i$ ) is

$$V_i = V_{ab} \frac{1.2M+1.2M+3k+3k}{3k+3k} = 1,600 \text{ V} \quad (17)$$

Thus, the measurement range is above or equal to 4 V to a maximum of 1,600 V.

Also, this design needs to consider the power dissipation of the use of resistor components. Using Ohm's law formula, the maximum current ( $i_{max}$ ) passing through the resistor component is equal to

$$i_{max} = \frac{1,600}{2.4M} = 6.67 \times 10^{-4} \text{ A} \quad (18)$$

Then the power dissipation ( $P$ ) on the resistor component ( $R$ ) is

$$\begin{aligned} P &= (i_{max}^2)R \\ &= (4.44 \times 10^{-7})R \end{aligned} \quad (19)$$

Based on (19), the power dissipation is obtained for a  $1.2 \text{ M}\Omega$  resistor of  $0.5333 \text{ W}$  and a  $3 \text{ K}\Omega$  resistor of  $0.0013 \text{ W}$ . Thus the use of resistor components in Figure 3 must be greater than the calculation of the power dissipation. The resistor component on the market has the lowest dissipation power of  $1/8 \text{ W}$  or  $0.125 \text{ W}$ . Therefore, the resistor component used in the design of Figure 3 must use a  $1.2 \text{ M}\Omega$  resistor with a minimum power dissipation of  $1 \text{ W}$  and a  $3 \text{ K}\Omega$  resistor with a minimum power of  $1/8 \text{ W}$ .

### B. Arduino Uno Programming

Arduino Uno programming flowchart can be seen in Figure 4. The initialization section in the flowchart explains the initial steps of Arduino running a program. There are four initial steps. First, Arduino Uno regulates communication with the ADC. Arduino Uno can communicate with ADC through I<sup>2</sup>C (Inter-Integrated Circuit) communication by connecting each SCL and SDA pins as shown in Figure 5. According to [12], Arduino Uno needs to access the address of  $0x48$  on ADS1115 so that communication can occur. The following code is exemplified by [12]

```
Adafruit_ADS1115 ads(0x48);
ads.begin();
```

Second, Arduino Uno regulates internal serial communication so that it can display data on the Serial Monitor. The following code is exemplified [9] and [11]

```
Serial.begin(9600);
```

Third, Arduino Uno sets the variables declaration that will be used in the program. The variables are `dAI`, `realValue`, and `multiply`. The `dAI` variable is a variable for storing the result of the conversion of the differential method in the form of 16-bit integers. The choice of data forms on the `dAI` variable accords to the maximum amount of data that can be converted, which also matches the ADC used. The `realValue` variable is a variable to change the value of the `dAI` variable to the actual value in the form of float. The `multiply` variable is a multiplier in the form of a 16-bit integer in the calculation of the `realValue` variable. The following variable declaration codes are

```
int16_t dAI;
uint16_t multiply;
float realValue;
```

Fourth, one digital IO (Input-Output) pin of Arduino Uno is set as output. The function is to control the Switch (see Figure 3 and Figure 5). The pin can be set to low or high states. When the pin is

set to low state, the Switch is inactive and in this condition, the measurement is in Mode B. If the pin is set to high, the Switch becomes active and the measurement is in Mode A. In this study, the digital IO pin uses pin 2. At the initial step, this pin is set to low. The following codes are

```
pinMode(2, OUTPUT);
digitalWrite(2, LOW);
```

The process part of the flow chart is the ADC looping process of converting data. Analog data conversion into digital data in the form of 16-bit integer data, so the total integer data is  $2^{16} = 65,536$  data. Referring to [9] and [11] with the default setting of the internal data gain of ADC, each bit of ADS1115 has a value of 0.1875 mV. This value is far better than the value of each bit in [4]-[6]. The differential measurement using pins A0 and A1 on ADS1115 [11], the following codes are

```
dAI=ads.readADC_Differential_0_1();
realValue=dAI*multiply*0.1875;
```

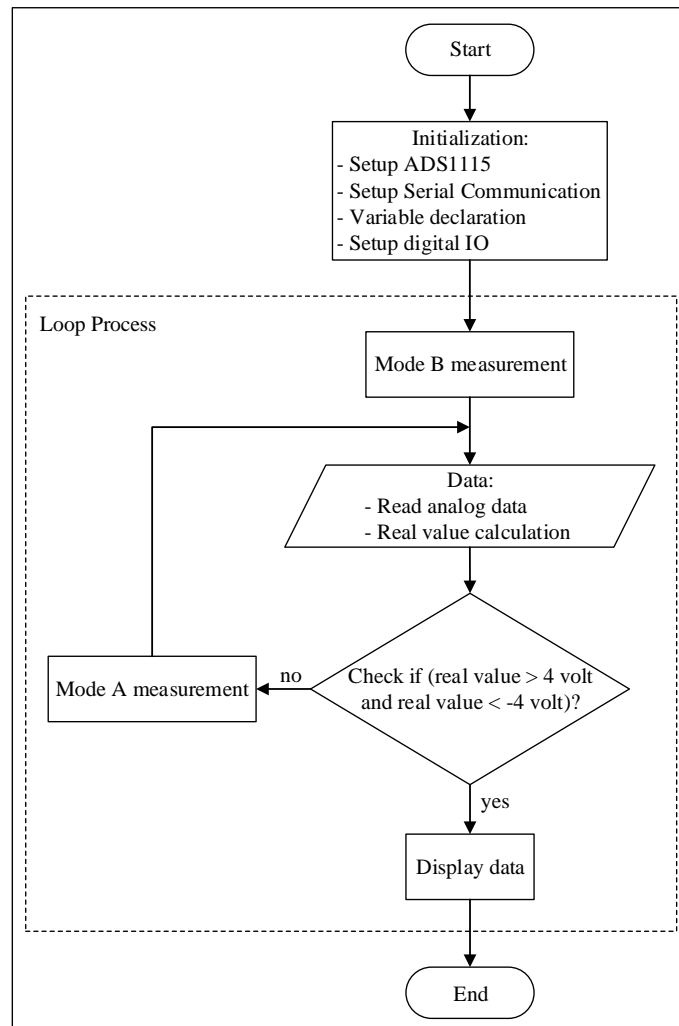

Figure 4. Flowchart of Arduino Uno programming

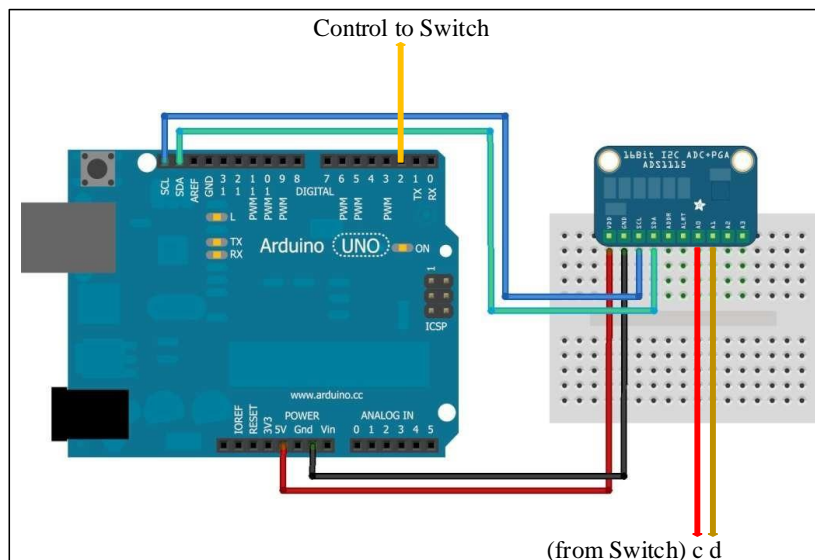

Figure 5. Arduino Uno and ADS1115 assembly (modified from [11] and [13])

The value of the multiply variable adjusts the mode used. In Mode A, the multiply variable has a value of 1 and in Mode B, the multiply has a value of 400 (see the multiplier value in (17)). The first time the ADC converts data, the measurement is in Mode B. Then the mode selection is automatic depending on the input potential value (see Figure 3). For this reason, it needs a conditioning state so that the mode selection can be achieved, which is at a value of 4 V. The calculated value on the realValue variable has a unit of mV, then the conditioning state value becomes 4,000 mV. This design can allow reversed polarity, so there is an additional conditioning state value of -4,000 mV. The following is the conditioning state code for auto-range to occur,

```

if(realValue < -4000.00 and
   realValue > 4000.00)
{
  multiply = 400;          //Mode B
  digitalWrite(2, LOW); //Switch off
}
else
{
  multiply = 1;           //Mode A
  digitalWrite(2, HIGH); //Switch on
}

```

Then the realValue value is displayed on the Serial Monitor. The value is displayed continuously with an interval of one second.

### III. RESULTS AND DISCUSSION

Figure 6 is a prototype system. The system testing is carried out by measuring the potential difference value on material resistances in the form

of resistor components ( $R$ ) (tolerance of 5%) that assembled according to Figure 2. The system testing is divided into two parts, testing on large resistances and small resistances. Testing on large resistances is carried out by providing the value variations of the voltage source ( $V_S$ ) from 1.5 to 60 V on the  $R$  component with values of 10 K $\Omega$  and 100 K $\Omega$ . Whereas testing on the small resistances is carried out by giving a  $V_S$  of 3 V to the  $R$  component with values of 15  $\Omega$ , 100  $\Omega$ , and 1,000  $\Omega$ .

The measurement results in the circuit are compared with the measurement results of a voltmeter with UT61B type in the same circuit. UT61B is an auto-range multimeter that can measure the potential difference from the order of mV up to 1,000 V with internal resistance between 3 M $\Omega$  - 10 M $\Omega$  [14].

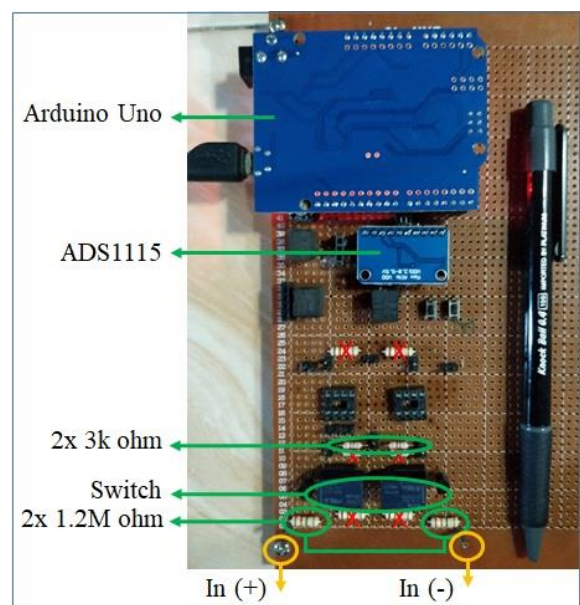

Figure 6. Voltmeter prototype

In the measurement table, there are several symbols used, namely  $V_1$ ,  $V_2$ , and  $V_3$ .  $V_1$  is the potential difference value in the unit of volt calculated based on (4).  $V_2$  is a potential difference value in the unit of volt based on measurement data using a UT61B Voltmeter. The measurement data of potential differences in units of mV is carried out by a prototype system with the symbol of  $V_3$ . Then there is the term *Error* in the unit of percentage, which shows the different measurements made by the system and the UT61B Voltmeter with the following equation

$$Error = \left| \frac{V_3 - V_2 (\text{in mV})}{V_2 (\text{in mV})} \right| \times 100\% \quad (20)$$

**A. Testing on Large R**

Table 1, Table 2, Table 3, and Table 4 show that measurements on the system are unstable. Each adjustment of the voltage source that applied to the circuit, the measurement error rate shows a greater pattern even though there are some data with smaller error rates compared to data before and after the adjustment of the voltage source occurs. This likely happened because there was random noise in the system.

**Table 1. Potential difference measurement in normal position with 10 KΩ**

$V_S$ (volt)	$V_1$ (volt)	$V_2$ (volt)	$V_3$ (millivolt)	<i>Error</i> (%)
1.50	0.50	0.51	402.75	21.03
2.10	0.70	0.71	562.13	20.83
2.70	0.90	0.91	770.81	15.30
3.00	1.00	1.01	942.38	6.70
6.00	2.00	2.02	1,854.94	8.17
12.00	4.00	4.02	3,737.44	7.03
18.00	6.00	5.93	5,484.75	7.51
24.00	8.00	7.98	7,647.75	4.16
30.00	10.00	9.97	9,810.75	1.60
60.00	20.00	19.95	19,776.00	0.87

**Table 2. Potential difference measurement in reversed polarity with 10 KΩ**

$V_S$ (volt)	$V_1$ (volt)	$V_2$ (volt)	$V_3$ (millivolt)	<i>Error</i> (%)
1.50	0.50	-0.51	-410.81	19.45
2.10	0.70	-0.71	-609.19	14.20
2.70	0.90	-0.91	-772.50	15.11
3.00	1.00	-1.01	-903.00	10.59
6.00	2.00	-2.02	-1,857.38	8.05
12.00	4.00	-4.02	-3,756.56	6.55
18.00	6.00	-5.98	-5,871.00	1.82
24.00	8.00	-7.98	-7,416.00	7.07
30.00	10.00	-9.98	-9,888.00	0.92
60.00	20.00	-19.95	-19,698.75	1.26

**B. Testing on Small R**

Testing using a 3 V voltage source is carried out so that the potential difference value based on calculations and measurements is equal to 1 V. This is because looking at the actual raw measurement data in the field from [3], the potential difference data has an average of about 1 V with an average resistance value obtained around 100 Ω. Measurements in Tables 5 and Table 6 show stable data even though the value approach (or level of confidence) is around 97% of the UT61B data results.

Measurement data in Tables 5 and Table 6 show measurement data with a better value approach compared to measurement data in Tables 1 - Table 4 on the use of the same voltage source. The use of component *R* has a tolerance of 5%, so this will give the effect that the value approach is not appropriate if the *R* values in Table 1 – Table 6 are substituted in (9) and (2), which should produce a confidence level of around 99%.

**Table 3. Potential difference measurement in normal position with 100 KΩ**

$V_S$ (volt)	$V_1$ (volt)	$V_2$ (volt)	$V_3$ (millivolt)	<i>Error</i> (%)
1.50	0.50	0.50	357.75	28.45
2.10	0.70	0.70	487.31	30.38
2.70	0.90	0.90	642.75	28.58
3.00	1.00	1.00	650.25	34.98
6.00	2.00	1.98	1,430.06	27.77
12.00	4.00	3.97	3,282.19	17.33
18.00	6.00	5.88	5,407.50	8.04
24.00	8.00	7.84	7,647.75	2.45
30.00	10.00	9.80	8,729.25	10.93
60.00	20.00	19.59	17,844.75	8.91

**Table 4. Potential difference measurement in reversed polarity with 100 KΩ**

$V_S$ (volt)	$V_1$ (volt)	$V_2$ (volt)	$V_3$ (millivolt)	<i>Error</i> (%)
1.50	0.50	-0.50	-276.19	44.76
2.10	0.70	-0.70	-444.56	36.49
2.70	0.90	-0.90	-559.88	37.79
3.00	1.00	-1.00	-647.44	35.26
6.00	2.00	-1.98	-1,423.13	28.12
12.00	4.00	-3.95	-3,129.94	20.76
18.00	6.00	-5.88	-5,716.50	2.78
24.00	8.00	-7.83	-7,416.00	5.29
30.00	10.00	-9.79	-8,883.75	9.26
60.00	20.00	-19.59	-17,999.25	8.12

**Table 5. Potential difference measurement in normal position with a voltage source of 3 V**

Resistor (ohm)	$V_1$ (volt)	$V_2$ (volt)	$V_3$ (millivolt)	Error (%)
15	1.00	1.01	987.75	2.20
100	1.00	1.02	996.75	2.28
1,000	1.00	1.03	1006.88	2.24

**Table 5. Potential difference measurement in reversed polarity with a voltage source of 3 V**

Resistor (ohm)	$V_1$ (volt)	$V_2$ (volt)	$V_3$ (millivolt)	Error (%)
15	1.00	-1.01	-973.31	3.63
100	1.00	-1.02	-989.06	3.03
1,000	1.00	-1.03	-1002.75	2.65

The Voltmeter in the systems of [4]-[7] didn't take into account the potential difference measurements when reversed polarity, so this prototype system can replace them. This system is very good at replacing the Voltmeter at [4] and [5] because of the potential difference measurements is up to tens of volts. Whereas the Voltmeter in [6] and [7] took the measurements in a range of under tens of mV, so this system hasn't been tested the measurements in the unit range due to limited testing facilities.

#### IV. CONCLUSION

Based on the system testing with several conditions, the system built using ADS1115 and Arduino Uno components can be used as an auto-range Voltmeter and measure the potential difference value in reversed polarity, so the system can be applied for DC resistivity measurement. Based on the measurement data, the Voltmeter is good for measuring potential difference value in low material resistances below 10 KΩ with a confidence level of 97%. Whereas in large material resistance is not good if the measurements are made above 10 KΩ. For further development, it is necessary to reduce noise in the system and need a voltage source with a range of below hundreds of mV for testing the potential difference measurement in the unit range of mV because there is a possibility when measuring the actual DC resistivity, the potential difference value will be in that unit range.

#### REFERENCES

[1] R. H. Manrulu, A. Nurfalaq, and I. D. Hamid, "Pendugaan Sebaran Air Tanah Menggunakan

Metode Geolistrik Resistivitas Konfigurasi Wenner dan Schlumberger Di Kampus 2 Universitas Cokroaminoto Palopo," *Jurnal Fisika Flux*, vol. 15, no. 1, pp. 6-12, Feb. 2018.

[2] F. D. Sastrawan and J. A. Latifan, "Estimasi Kedalaman Akuifer Dangkal Daerah TPA Manggar dengan Menggunakan Metode Geolistrik Konfigurasi Wenner", *Jurnal Sains Terapan*, vol. 5, no. 2, pp. 131-136, Oct. 2019.

[3] Hakim and R. H. Manrulu, "Aplikasi Konfigurasi Wenner Dalam Menganalisis Jenis Material Bawah Permukaan", *Jurnal Ilmiah Pendidikan Fisika Al-BiRuNi*, vol. 05, no. 1, pp. 95-103, Apr. 2016.

[4] B. Indarto, G. R. F. Sudenasahaq, D. B. Rachmad, M. H. Basri, and H. Sunarno, "Rancang Bangun Sistem Pengukuran Resistivitas Geolistrik dengan menggunakan Sumber Arus Konstan", *Jurnal Fisika Dan Aplikasinya*, vol. 12, no. 2, pp. 83-89, Jun. 2016.

[5] Maison, K. N. Sawitri, Samsidar, L. Handayani, R. Purbakawaca, and J. Nurjaman, "Design of digital resistivity-meter for subsurface exploration", in *IOP Conf. Series: Journal of Physics: Sriwijaya Int. Conf. on Basic and Applied Science*, 2019, pp. 1-8.

[6] D. Fatahillah, Darsono, and Nuryani, "Low-cost multi electrode resistivity meter based on microcontroller for electrical resistivity tomography purpose", in *IOP Conf. Series: Journal of Physics: 9th Int. Conf. on Physics and Its Applications (ICOPIA)*, 2019, pp. 1-6.

[7] I. C. Setiadi, "Desain Sumber Arus untuk *Electrical Impedance Tomography* (EIT)", *Jurnal Arus Elektro Indonesia*, vol. 1, no. 3, pp. 27-33, Dec. 2015.

[8] Scintrex Automated Resistivity Imaging System (SARIS) Operation Manual, rev. 2, Scintrex Ltd., Concord, Ontario, Canada, 2013, pp. 5-1.

[9] (2020) Electronoobs. [Online]. Available: [http://www.electroobs.com/eng\\_arduino\\_tut84.php](http://www.electroobs.com/eng_arduino_tut84.php)

[10] S. R. Manurung and M. Sinambela "Perangkat Pembelajaran IPA Berbentuk LKS Berbasis Laboratorium", *Jurnal Inovasi Pembelajaran Fisika*, vol. 6, no. 1, pp. 80-87, Feb. 2018.

[11] (2020) Henrysbench website [Online]. Available: <http://henrysbench.capnfatz.com/henrysbench/arduino-voltage-measurements/arduino-ads1115-differential-voltmeter-tutorial/>

[12] (2020) Henrysbench website. [Online]. Available: <http://henrysbench.capnfatz.com/henrysbench/arduino-voltage-measurements/arduino-ads1115-module-getting-started-tutorial/>

[13] (2019) Bill Earl. [Online]. Available: <https://cdn-learn.adafruit.com/downloads/pdf/adafruit-4-channel-adc-breakouts.pdf?timestamp=1591600159>

[14] Model UT61A/61B/61C/61D/61E: Operating Manual, rev. 9, UNI-Trend Technology (China) Co., Ltd., Dongguan, Guangdong, China, 2018, pp. 44.