

Simulated data of urea of haemodialysis patient using one-compartment model

¹Nabilah Solehah Ahmad Tamrin, ¹Noorddin Ibrahim

¹Department of Defence Science, National Defence University of Malaysia, Kem Sungai Besi, 57000 Kuala Lumpur, Malaysia.

Corresponding Author: nabilahsolehah@gmail.com

Abstract. End stage kidney disease (ESKD) is a disease where both kidneys are no longer functioning properly and patients require renal replacement therapy (RRT) such as haemodialysis to prolong their life. The numbers of modality for haemodialysis had increased, as the numbers of new patient of ESKD increased. In Malaysia, the numbers of new patient had increased three-fold for the past 10 years, from year 2002 to year 2012. In this paper, demographic data, clinical data and input and output of dialysis for the selected patients are presented. The post-dialysis urea concentrations for each patient with different weight for one compartment model were simulated using MATLAB software. The simulated values of post-dialysis urea concentration were then compared with the clinical values of post-dialysis urea concentration for different weight. The simulated values of post-dialysis urea concentration underestimated the clinical value of post-dialysis urea concentration for patient with weight less than 70kg but overestimated to patient with weight greater than 70kg. The ratio of simulated values and clinical values of post-dialysis urea concentration were found to increase with the weight of patient.

Key words:simulation, urea concentration, haemodialysis, one compartment model, urea kinetic modelling.

Introduction

The incidence and prevalence of dialysis patient is increasing throughout the world (Shaheen& Al-Khader 2005;Shaza et al. 2005). In 2012, National Renal Registry (NRR) reported that the prevalence of end stage kidney disease (ESKD) had increased three-fold from 9,107 at the end of 2002 to 25,688 at the end of 2011. The new cases had risen from 2,375 to at least 5,201 per year between year 2002 and 2011. The incidence per million population (pmp) increased from 96 in 2002 to 181pmp in 2011. Currently, there are more than 639 haemodialysis centres and 7,088 haemodialysis machines provided for dialysis patients in Malaysia. Most of these patients are on haemodialysis treatment, rather than peritoneal dialysis (Lim et al. 2003; Lim et al. 2012).

End stage kidney disease is a disease where both kidneys lost their ability to function normally, which makes renal replacement therapy (RRT) a necessity for survival (Hassanien et al. 2012). It is associated with high retention of metabolic waste products such as urea and creatinine in the body fluid (Walker et al. 1975). A patient is classified as ESKD when the glomerular filtration rate (GFR) is less than 15ml/min/1.73m² (Levy et al.2009). The removal of waste products from the body in ESKD is achieved only with Renal Replacement Therapy (RRT). RRT consists of two treatments: dialysis and renal transplantation. Dialysis comprises of two modalities: haemodialysis (HD) and peritoneal dialysis (PD). HD removes the toxins through an artificial semipermeable membrane (dialyser) while PD removes the wastes from circulated blood in the capillaries that supply the semipermeable membrane

(peritoneum) and requires a catheter inserted into the peritoneal cavity (Daugirdas et al. 2007; Levy et al. 2009).

Concentration of urea and creatinine decreased during dialysis treatment and increased, between dialyses. By removing these wastes, extra salts and fluid, it helps to control blood pressure and keep proper balance of chemicals such as potassium and sodium in the body. Most patients visit the haemodialysis centre for 3 to 5 hours treatment, typically 4 hours for two to three times a week (Ing et al. 2000; Waniewski 2006).

This paper presents the comparison of the simulated value of post-dialysis urea concentration with the clinical value of patients for different body weight based on one-compartment model.

Materials and Methods

A retrospective study of haemodialysis treated at haemodialysis unit in Hospital Sultanah Aminah (HSA), Johor, Malaysia over a 5 years period (2007-2011) was undertaken with approval from Medical Research Ethics Committee (MREC), National Institutional of Health (NIH) and director of HSA. 32 stable uremic patients aged between 20 and 80 years old, undergone dialysis for more than 5 years were selected as the subjects of study. Forms were drawn up to gather the patients' demographic data such as age, gender and race and patients' clinical data. Besides, dialysis input and outcomes for four hours treatment were also recorded. Collected data were entered into Microsoft Excel datasheet, analysed and simulated using MATLAB software.

From the data obtained, post-dialysis urea concentration for one compartment model as in Figure 1 was simulated to compare the values between the clinical data and simulated values. Equation 1 and equation 2 were used to calculate the volume of body fluid and the value of post-dialysis urea concentration ([Sanfelippo et al. 1978](#); [Lee & Chang 1989](#)). Residual kidney clearance (K_r) was negligible during the simulation due to its small value compared to dialyser clearance (K_d).

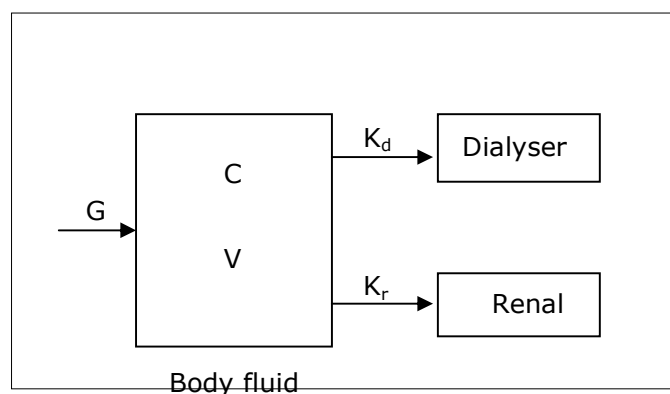

Figure 1. Schematic diagram for one-compartment model.

$$V (l) = \frac{40}{70} \times \text{body weight (kg)} \quad (1)$$

$$C(t) = \frac{G}{(K_d + K_r)} + \left(C(0) - \frac{G}{(K_d + K_r)} \right) e^{-\frac{(K_d + K_r)t}{V}} \quad (2)$$

where C(t) is the post-dialysis urea concentration, C(0) is the pre-dialysis urea concentration, K_d is the dialyser clearance, K_r is the residual renal clearance, G is the urea generation rate, V is the volume distribution and t is time.

Results and Discussion

Among 32 HD patients, there were 12 male and 20 female. The ethnic distributions were 59.4% Malay and 40.6% Chinese and Indian. The mean age for HD patient was found to be 52± 13years old with a median of 53. The number of cases was highest in the age group 40-64 years old where twenty-one (65.6%) were in that age range, consistent with the NRR data ([Lim et al. 2012](#)). Table 1 shows the demographic data for the patients under study.

Clinical data consists of patients' weight and concentration of urea and electrolytes, before and after the dialysis treatment. Mean pre-dialysis weight for the HD patient was 57.92kg while mean post-dialysis weight was 56.02kg. The average percentage reduction in patients' weight was 3.28%.

Table 1. Demographic data of 32 haemodialysis patients.

Demographic Variable	Patientsn=32
Mean age, years	51.78±12.96
Young (19-39)	3 (9.4%)
Middle (40-64)	21 (65.6%)
Old (≥65)	8 (25.0%)
Gender	
Male	37.5%
Female	62.5%
Race	
Malay	19 (59.4%)
Chinese	9 (28.1%)
Indian	4 (12.5%)

Mean pre-dialysis urea concentration was 18.31 ± 4.30 mmol/l and mean post-dialysis urea concentration was 4.32 ± 1.66 mmol/l. The average pre-dialysis urea concentration exceeded the normal range at almost 10.00 mmol/l. Normal range for urea concentration was between 1.7 mmol/l and 8.3 mmol/l. Average value of urea reduction ratio (URR) for HD patient was 76.60%. It achieved the minimum target of URR recommended by European Best Practice Guidelines for patients on thrice-weekly HD which was >65%. Average concentrations of creatinine, before and after the dialysis treatment were $73.78 \mu\text{mol/l}$ and $23.57 \mu\text{mol/l}$, respectively. Creatinine is a type of waste produced from the activity of muscle. The percentage reduction in creatinine concentration in a dialysis treatment was 68.61%.

Sodium and potassium are two important electrolytes in maintaining the acid-base balance. Both minerals are transported across the membrane by active transport mechanism. The average concentration of sodium before the dialysis treatment was 134.83 mmol/l with standard deviation of 2.11 while the average concentration of sodium after the dialysis treatment was 134.75 ± 1.75 mmol/l. As for potassium, the mean pre-dialysis concentration and post-dialysis concentration were 4.31 and 3.01 mmol/l, respectively. The percentage reductions for both minerals were 0.04% for sodium and 29.80% for potassium. The other data were shown in Table 2.

Before dialysis treatment, few parameters were set such as blood flow rate, dialysate flow rate and dialyser clearance (K_d) was measured. The residual renal function was negligible (K_r). The blood flow rate was 312.62 ± 5.05 ml/min, dialysate flow 500.83 ± 4.71 ml/min and the average mean dialyser clearance for all patients was 218.74 ± 4.81 ml/min with median of 225.08.

Outcomes from the dialysis treatment were time-averaged concentration (TAC), urea or solute generation (G), adequacy of the dialysis treatment (Kt/V) and normalised protein catabolic rate (PCRn). The average value of TAC was 25.44 mg/dl with median of 26.23. Mean generation of urea in the liver was 5.05 ± 1.56 mg/min. The average adequacy value was 1.78/dialysis. According to National Kidney Foundation (2006), adequate dialysis is defined as the amount of dialysis yielding satisfactory clinical results. The recommended target Kt/V for HD was ≥ 1.2 . The results showed that Kt/V achieved the target. Mean and standard deviation of normalised protein catabolic rate (PCRn) was 1.03 ± 0.20 g/kg/. Normalised protein catabolic rate indicates the diet intake of a patient. A target of 1.0-1.2 g/kg/day recommended by America and Europe guidelines.

Table 2. Mean±SD of patients' clinical data.

Clinical data	Median	Mean±SD
Weight (kg)		
Pre-dialysis	56.92	57.92±9.94
Post-dialysis	54.76	56.02±9.66
Urea concentration(mmol/l)		
Pre-dialysis	17.12	18.31±4.30
Post-dialysis	3.76	4.32±1.66
Creatinine concentration (µmol/l)		
Pre-dialysis	60.07	73.78±17.20
Post-dialysis	21.59	23.57±8.25
Sodium concentration (mmol/l)		
Pre-dialysis	135.11	134.83±2.11
Post-dialysis	135.18	134.75±1.75
Potassium concentration (mmol/l)		
Pre-dialysis	4.37	4.31±0.44
Post-dialysis	3.03	3.01±0.21
Uric acid (µmol/l)	383.92	391.40±56.29
Total protein (g/l)	76.15	75.72±4.44
Albumin (g/l)	39.64	39.38±2.49
Calcium (mmol/l)	2.28	2.27±0.20
Phosphate (mmol/l)	1.65	1.81±1.06
Magnesium (mmol/l)	1.18	1.18±0.08

Table 3. Dialysis input and outcomes

Dialysis variables	Median	Mean	SD
Input			
Blood flow (ml/min)	303.69	312.62	25.05
Dialysate flow (ml/min)	500.00	500.83	4.71
Outcomes			
Time-averaged concentration (mg/dl)	26.23	25.44	5.92
Solute generation (mg/dl)	4.77	5.05	1.56
Kt/V(/dialysis)	1.74	1.78	0.25
Protein catabolic rate (PCRn) (g/kg/day)	0.99	1.03	0.20

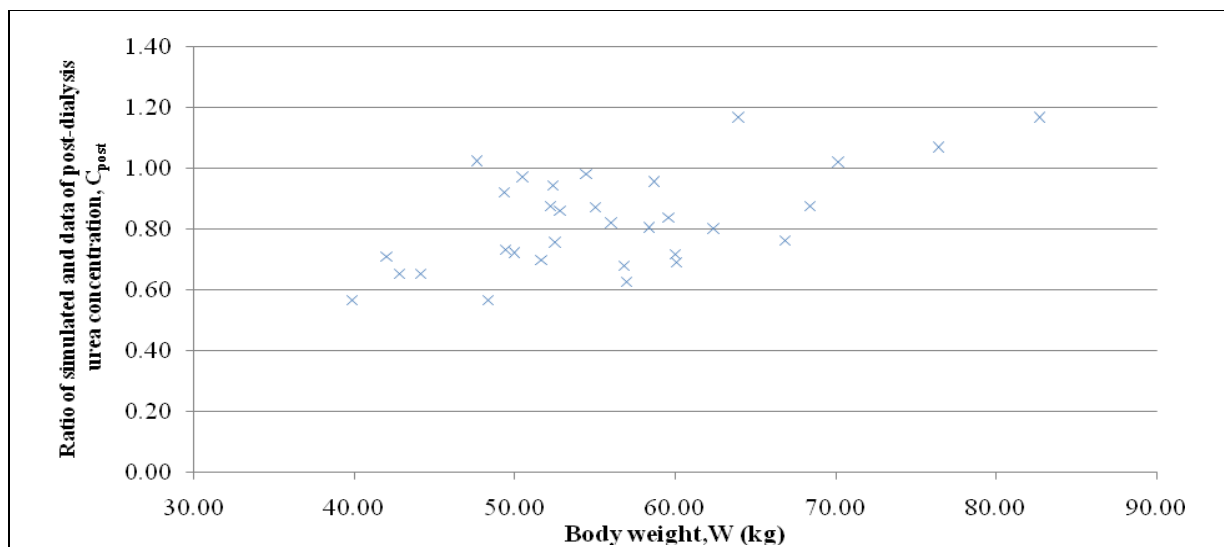

Figure 2. Ratio of simulated post-dialysis urea concentration to data of post-dialysis urea concentration for different body weight.

Based on one-compartment model, we found that post-dialysis urea concentration increased with patient's weight. Figure 2 shows the relationship between the ratios of post-dialysis urea concentrations with patients' weight for one compartment model. From that figure, we can see that the ratio of simulated value of post-dialysis urea concentration with clinical data for patient with weight below than 70kg were underestimated, while for patient of more than 70kg were overestimated. This shows that one compartment model cannot be used to predict the percentage of urea after the dialysis treatment. Our study has several limitations. Some data were not available particularly for patients transferred from other

centres. Data were only available for resources utilised within the hospital regardless of what may have been consumed in other health care centres. However, this will not significantly change the final results.

Conclusions

In conclusion, the ratio of simulated and data post-urea concentration increase with the weight of patient.

Acknowledgements

The authors acknowledged the financial support from government in term of scholarship. The authors are grateful to National Health Institution (NIH) and Unit Haemodialysis, Hospital Sultanah Aminah for giving us the permission to collect the data.

References

- Daugirdas J.T., Blake P.G., Ing T.S. 2007. Handbook of Dialysis, 4e (Vol. 236), Lippincott Williams & Wilkins.
- Hassanien A.A., Al-Shaikh F., Vamos E.P., Yadegarfar G., Majeed A. 2012. Epidemiology of End-Stage Renal Disease in the Countries of the Gulf Cooperation Council: A Systematic Review, *JRSM Short Rep*, 3:38.
- Ing T.S., et al. 2000. Observations on Urea Kinetic Modeling and Adequacy of Hemodialysis, *Hong Kong Journal of Nephrology*, 2:3-12.
- Lee C.J., Chang Y.L. 1989. A New Therapeutic Parameter and Computer Control to Approach Optimal Haemodialysis, *Computer Methods and Programs in Biomedicine*, 30:33-42.
- Levy J., Brown E., Daley C., Lawrence A. 2009. Oxford Handbook of Dialysis, Oxford University Press, USA.
- Lim T.O., Lim Y.N., Lee D.G. 2003. Tenth Report of the Malaysian Dialysis and Transplant Registry, Technical.
- Lim Y.N., Ong L.M., Goh B.L. 2012. Nineteenth Report of Malaysia Dialysis and Transplant Registry 2011, Technical.
- National Kidney Foundation 2006. KDOQI Clinical Practice Guidelines and Clinical Practice Recommendations for 2006 Updates: Hemodialysis Adequacy, Peritoneal Dialysis Adequacy and Vascular Access, *American Journal of Kidney Diseases*, 48:S1-S322.
- Sanfelippo M.L., Walker W.E., Hall D.A., Swenson, R.S. 1978. Clinical Application of a Single Compartment Model to Urea and Creatinine Kinetics in Dialysis Therapy, *Computer Programs in Biomedicine*, 8:44-50.
- Shaheen F.A., Al-Khader A.A. 2005. Epidemiology and Causes of End Stage Renal Disease (EsrD), *Saudi Journal of Kidney Diseases and Transplantation*, 16:277-281.
- Shaza A.M., Rozina G., Izham M.I., Azhar, S.S. 2005. Dialysis for End Stage Renal Disease: A Descriptive Study in Penang Hospital, *Medical Journal of Malaysia*, 60:320-327.
- Walker W.E., Hall D.A., Sanfelippo M.L., Swenson R.S. 1975. Application of a Programmable Pocket Calculator to a Single Compartment Mathematical Model of Solute Kinetics, *Computer Programs in Biomedicine*, 5:99-104.
- Waniewski J. 2006. Mathematical Modeling of Fluid and Solute Transport in Hemodialysis and Peritoneal Dialysis, *Journal of Membrane Science*, 274:24-37.