

IoT Based Wind / Solar Hybrid Inverter

Ajeeth Kumar S., Shabarish G., Kishore Kannan A.

Department of EEE, Department of Mechatronics Engineering, Aarupadai Veedu Institute of Technology, India

Article Info

Article history:

Received Jun 21, 2016

Revised Aug 14, 2016

Accepted Aug 22, 2016

Keyword:

IoT

Photovoltaic

Wind turbine

Wind/solar hybrid inverter

ABSTRACT

Paper deals with power control of a wind and solar hybrid generation system for connection operation with electric distribution system. Power control strategy is to extract the maximum energy available from varying condition of wind speed and solar irradiance while maintaining power quality at a safety level. In order to verify the maximum power variable speed control is come for wind turbine and maximum power is applied for PV system. inverter transfers the energy from the wind turbine and PV array into the grid by keeping common dc voltage constant. To ensure safety these inverters automatically shut down in the event of High/Low AC-voltage; High/Low frequency; IoT is a key feature in which safety measurement is current and voltage. The results show the control performance and behavior of the wind/PV system solar and wind are major possible ways were energy level are stored in battery, we implement to ensure that power transmission ways in hybrid pv/wind power are stored properly in batteries. Our aim is to monitor the current and voltage by means of IoT. the wave distribution of voltage and current is checked rapidly by using IoT. non regular checking of voltage and current leads to total damage. And so we ensure that damage are monitored over IoT, variable power raise and drop are checked over by IoT. PV and wind power

Copyright © 2016 Institute of Advanced Engineering and Science.
All rights reserved.

Corresponding Author:

Ajeeth Kumar S,

UG scholar, Department of EEE, Department of Mechatronics Engineering,

Aarupadai Veedu Institute of Technology,

Chennai, Tamilnadu, India.

1. INTRODUCTION

Wind turbine and photovoltaic generation TECHNICS have brought opportunities of wind and solar resources for electric power generation. They have random behaviors. solar radiation and wind speed, have strong profiles Wind/solar complementary power supply system power supply which makes good use of wind and solar energy. In this system can not only provide a bargain of low cost and high dependability for some region where power transmission is not convenient such as frontier defenses and sentry, relay stations of communication, a farming or pasturing area and so on, but also inaugurate a new area of IoT monitoring which resolve the crisis of energy sources and environment .variable energy level is all the system or wind system individually, for the restriction of time and region. So, a system that is based on renewable resources on voltage and current but at the same time reliable is necessary and wind/solar hybrid system [1-5].

2. BLOCK DIAGRAM

The Studied Hybrid System Configuration is shown in Figure 1.

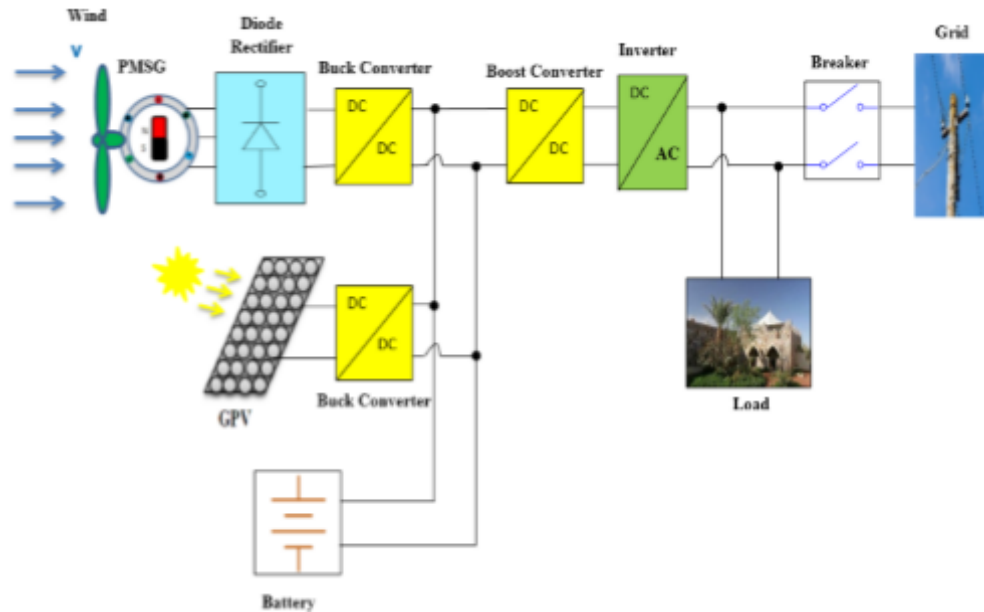

Figure 1. The Studied Hybrid System Configuration

3. MODELING OF POWER ON PV/WIND

3.1. DC/DC Boost Converter

In this model, boost converter had been controlled to yield the constant output DC voltage level, V_0 by varying the duty ratio, in response to variations V_i .

$$V_o = \frac{1}{1-\alpha} V_i \quad (1)$$

$$I_o = (1-\alpha) I_i \quad (2)$$

3.2. DC/DC Buck Converter

The average output voltage of the buck converter is given by:

$$V_o = \alpha V_i \quad (3)$$

Assuming converter losses, the average output current is of the buck converter is given by

$$I_o = \frac{I_i}{\alpha} \quad (4)$$

3.3. Inverter Modeling

The output voltage of the inverter, V_{OP} , is the voltage between V_A and V_B , where V_A and V_B are the potentials at the points A and B with respect to the neutral potential ($V_N=0$). The voltage vector $[V_A \ V_B]^T$ can be expressed as:

$$\begin{bmatrix} V_A \\ V_B \end{bmatrix} = \frac{1}{2} V_{DC} \begin{bmatrix} 1 & -1 \\ -1 & 1 \end{bmatrix} \begin{bmatrix} a \\ b \end{bmatrix} \quad (5)$$

3.4. LC Filter

A system with forced commutation like *MLI* or other control techniques of voltage source inverter generates chopping harmonics. In order to eliminate these harmonics the insertion of a filter between the converter and the load, in the majority of the cases is a low passes band filter. This makes it possible to carry out the objective. Generally, LC Filter can be modeled using the equivalent circuit shown in Figure 2.

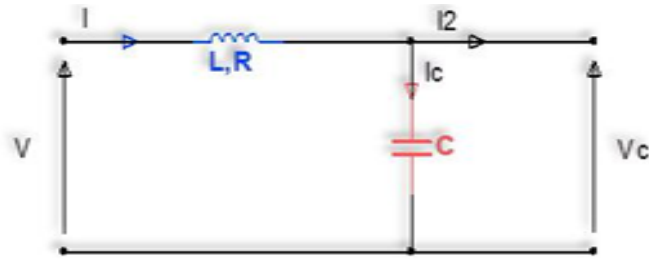

Figure 2. Equivalent Circuit of LC Filter

3.5. Phase Locked Loop (PLL)

The PLL can track the instantaneous network fundamental voltage phase and find its frequency. Other methods were developed but the majority of them are used only if the voltage signal is purely sinusoidal. The Phase Locked Loop (PLL) technique used to extract the direct fundamental component voltage phase in the low voltage electrical supply networks. General structure of a single phase PLL shown in Figure 3.

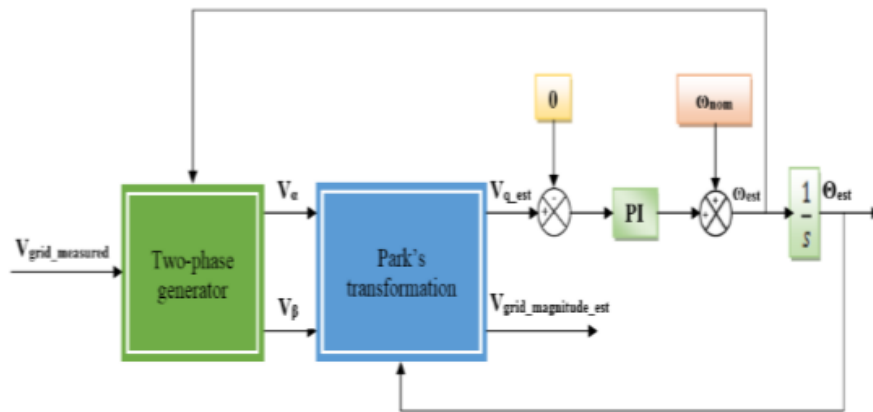

Figure 3. General Structure of a Single Phase PLL

4. PROPOSED CONTROL STRATEGY

Figure 4 shows the Wind control and the GPV control is shown in Figure 5.

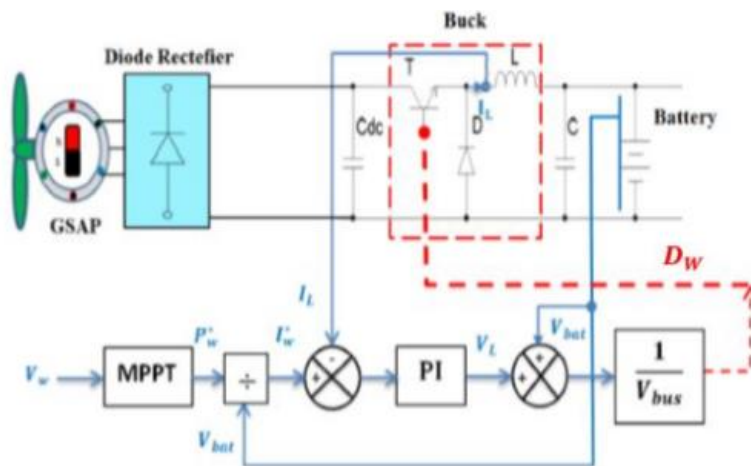

Figure 4. Wind control

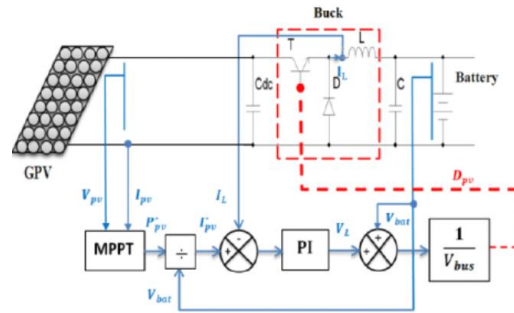

Figure 5. GPV Control

4.1. Boost Converter

A boost converter (step-up converter) is a DC to DC power converter that steps up voltage (while stepping down current) from its input (supply) to its output (load). It is a class of switched-mode power supply (SMPS) containing at least two semiconductors (a diode and a transistor) and at least one energy storage element: a capacitor, inductor, or the two in combination. To reduce voltage ripple, filters made of capacitors (sometimes in combination with inductors) are normally added to such a converter's output (load-side filter) and input (supply-side filter).

4.2. Buck Converter

A buck converter step-down converter is a DC-to-DC power converter which steps down voltage (while stepping up current) from its input supply to its output load. It is a class of switched-mode power supply (SMPS) typically containing at least two semiconductors (a diode and a transistor, although modern buck converters frequently replace the diode with a second transistor used for synchronous rectification) and at least one energy storage element, a capacitor, inductor, or the two in combination. To reduce voltage ripple, filters made of capacitors (sometimes in combination with inductors) are normally added to such a converter's output (load-side filter) and input (supply-side filter).

5. CONCLUSION

Solar power is well known to be an expensive solution to remote electrification. This cost can be reduced by adding wind turbine generators to reduce the reliance on PV. In this paper, we have focused on the study of photovoltaic wind production of electrical energy optimization as well as its transfer to the mono-phase electrical network supply through an inverter with minimum possible losses by using IoT and output by web page. The adopted approach was to improve the chain various parts point by point. a PV/wind system protection device is implemented i.e. This system is able to react to overvoltage, under voltages and frequency variations. It was subjected to an overvoltage, an under voltage and frequency variation. The system showed good results in each cited case. The small price difference between the classic solution and the island grid solution is justified by the flexibility and extendibility offered by the SMA system, in particular the addition of additional generation equipment at a later date. The type of connection of the different components to the system is just as important. The AC coupling with inverter allows we to connect nearly any type of electricity generator and any type of consumer to our system. This makes our system easily extendable on the consumer side as well as on the generator side.

REFERENCES

- [1] A. Mirecki, "Etude comparative de chaînes de conversion d'énergie dédiées à une éolienne de petite puissance" Thèse préparée au Laboratoire d' Electrotechnique et d'Electronique Industrielle de l'ENSEEIH Unité Mixte de Recherche CNRS N° 5828, N° d'ordre : 2213 Année 2005.
- [2] R. Melício, V. M. F. Mendes, J. P. S. Catalão, "Comparative study of power converter topologies and control strategies for the harmonic performance of variable-speed wind turbine generator systems," *Energy*, vol. 36, 2011.
- [3] F. Valenciaga and P. F. Puleston, "Supervisor Control for a Stand-Alone Hybrid Generation System Using Wind and Photovoltaic Energy" *IEEE Transactions On Energy Conversion*, vol. 20, no. 2, Jun 2005.
- [4] Z. Lubsony, *Wind Turbine Operation in Electric Power Systems*, Springer-Verlag, Germany, 2003.
- [5] A. Hoque, et K. A. Wahid, "New mathematical model of a photovoltaic generator (PVG)" *Journal of Electrical Engineering The Institute*.