

Performance Comparison of Fuzzy Logic and Proportional-integral for an Electronic Load Controller

M. Irfan, Machmud Effendy, Nur Alif, Lailis S, Ilham Pakaya, Amrul Faruq

Department of Electrical Engineering, Faculty of Engineering, University of Muhammadiyah Malang (UMM), Indonesia

Article Info

Article history:

Received Mar 17, 2017

Revised Jul 22, 2017

Accepted Aug 3, 2017

Keyword:

Electronic load control

Fuzzy logic

Micro hydro power plant

Proportional integral

ABSTRACT

Generally, Electronic Load Control (ELC) used in micro hydro power plant (MHPP) to controls the voltage between consumer load and a dummy load, still detects one parameter voltage or frequency generator only. Whereas in reality, any changes in the load on consumers, generator voltage and frequency also changed. When the consumer load down the electric current will be supplied to the dummy load, amounting to decrease in consumer load. When there is a transfer load, there will be distortion voltage and frequency, thus a special methods to reduce distortions by speeding up the process of transferring the electric load is needed. The proposed of this study is using fuzzy logic algorithm. To realize such a system, a comparison tool model of load control digital electronic fuzzy logic controller (FLC) and Proportional Integrator (PI) is required. This modeling using matlab program to simulate, the simulation result shows that the ELC based on fuzzy logic controller is better than conventional PI control, it seen from fast response to steady state condition.

Copyright © 2017 Institute of Advanced Engineering and Science.
All rights reserved.

Corresponding Author:

M. Irfan,

Department of Electrical Engineering, Faculty of Engineering,

University of Muhammadiyah Malang,

246 Raya Tlogomas Road, 65144 Malang, Indonesia.

Email: irfan_tsd@yahoo.com / mirfantsd@gmail.com

1. INTRODUCTION

Microhydro power plant is one of the renewable energy sources that has not been widely used in Indonesia. Based on data from the ESDM department, indonesia has a hydropower potential of 75 000 MW and currently only 13.9% that potential untapped [1], [2]. Therefore it should be increased use of the MHPP in the area that has the potential to build a microhydro, so that the electrical energy needs do not depend on the state electricity company.

The use of technology of application of power electronics devices is increasing lately [3]. Some applications that use these devices [4], for example: power conversion, motor speed control, control the efficiency of lighting and air conditioning, interface from the solar panels and many others. Recent studies about power energy has been conducted by [5]. Control of DFIG Stator Voltage on Autonomous Micro Hydro has been presented by [6]. In terms of the power conversion, power electronics devices used in the MHPP as a control voltage and frequency. The controller is called with electronic load control (ELC). The way it works is to transfer the surplus current from the main system to the dummy load.

At the moment the consumer electrical load decreased, then the electric current will be supplied to dummy load. When there is a transfer load, there is distortion voltage and frequency, so we need special methods to reduce distortion by accelerate the transfer of electrical load using specific control algorithms. To design the control requirement, based on the classical control theory and modern control theory. According to Aziz Ahmed [7] the use of classical control, usually using control PID, which require linear mathematical models. Even though PID control has a weakness in the system of nonlinear model. For

example in power electronics devices are DC-DC Converter, which has a switch with 3 conditions in one cycle of the switching frequency. To overcome the drawbacks of PID, as presented by Dragan M [8] non-linear models of electronic devices, can be transformed into state-space models using averaging method. However, method obtained can only be used to model small signals.

Modern control theory, built based on feedback control, self-tuning control, and adaptive control model [9], the controller also requires a mathematical model that is very sensitive to variations in the value of the parameter. In certain applications, the use of fuzzy logic control can solve several problems [10]. As studied by [11] et al, successfully applied Fuzzy Logic Controller (FLC) as an intelligence controller and optimized for non-linear model. Furthermore a comparison studied was also done with genetic algorithm technique [12]. The advantages of fuzzy logic control than conventional PID control is does not require a mathematical model that accurately, can work with the uncertain input value, can handle non-linear systems.

This study discussed the fuzzy logic control capabilities in power electronics devices, namely electronic load control (ELC). The simulation results will be shown as a result of fuzzy logic control capabilities in the application of power electronics circuits. The results of fuzzy logic control will be compared with conventional PI control.

2. RESEARCH METHOD

In designing this system, consists of several models, among other models of generator used is an induction generator, electric load models with maximum power of 3.5 kW, and a capacitor model as excitation by 4 kVar. Models created and simulated using matlab program. In the design, MHPP operated stand alone. Here is model of the MHPP equipped with ELC control based on fuzzy logic.

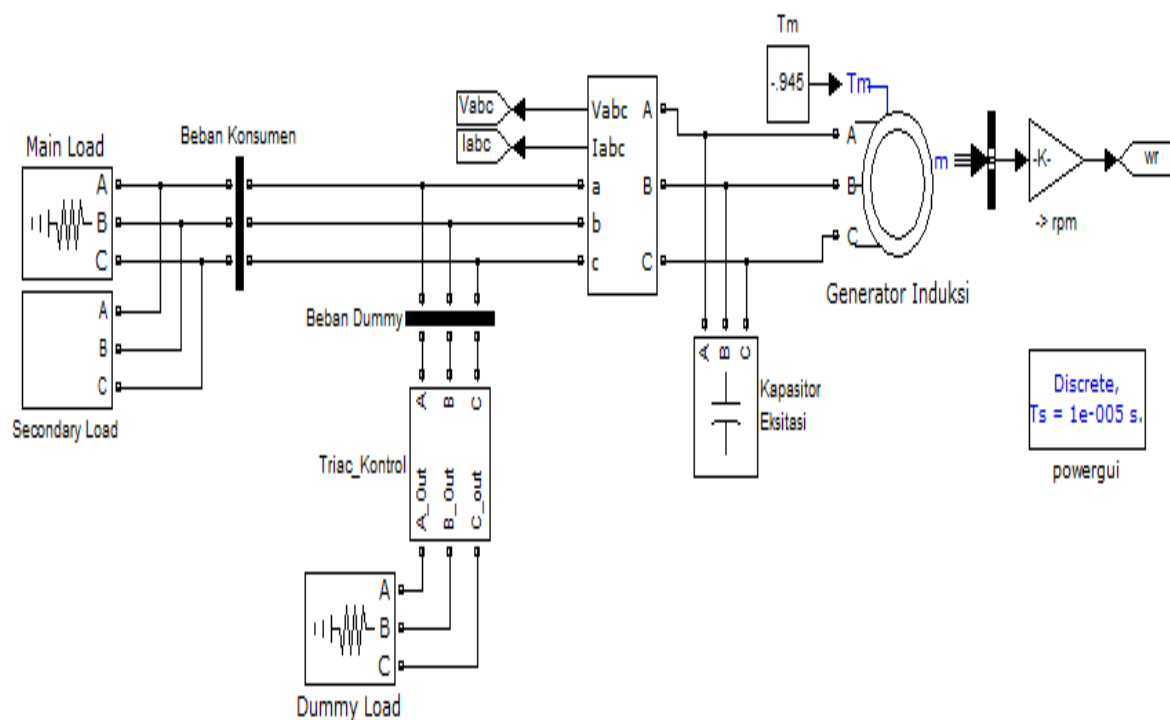

Figure 1. Model of Microhydro Power Plant based FLC

From Figure 1. Shows the MHPP system equipped with ELC. The system consists of several parts; induction generator model and excitation system; main load model and dummy load; electronic switch model and fuzzy logic control model. Generator is an important part of the system MHPP. In this paper, using a 3-phase induction generator with the parameters shown in Table 1.

Table 1. Values of parameters induction generator

No	Parameters	Value
1	Nominal power	4 000 (VA)
2	Voltage ph-ph	400 (Vrms)
3	Frequency	50 Hz
4	Stator Resistance(Rs)	0.03513 pu
5	Stator Inductance(Ls)	0.04586 pu
6	Rotor Resistance(Rr)	0.03488 pu
7	Rotor Inductance(Lr)	0.04586 pu
8	Inertia	0.0404 H(s)
9	Friction factor	0.01841 F(pu)
10	Pole pairs	2 p

Induction generator needs power reactive for generate a voltage.Reactive power supply comes from the component capacitor with a capacitance of 100 microfarads. Capacitors are installed in parallel with an induction generator and associated with the composition Y (Wye). Here is the Figure 2 model of excitation system in the form of capacitor components.

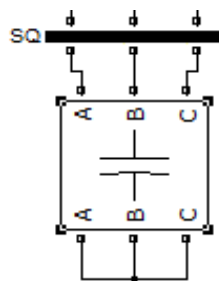

Figure 2. Excitation System Model.

Modeling the load in this system, using components of the load resistor. The load of one another, are arranged in parallel. On the other loads, paired a switch. This switch mounting purposes is to test changes in load power usage. The switch works is based on a predetermined time. The following Figure 3. shows a model of the load MHPP.

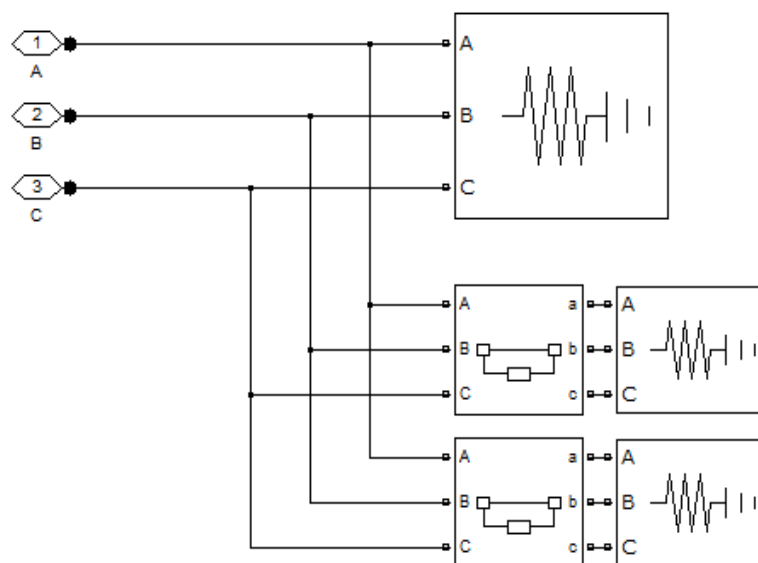

Figure 3. Top Load Model

The objective of this electronic switch is a to shift current that is not used by the load on consumers. component electronic switch that used is a thyristor that connected in parallel to form a component TRIAC. Installation of the switch is connected in parallel with the generator. The amount of current that is diverted depends on the size of the control signal given to the gate TRIAC. The following Figure 4, shows the configuration of the electronic switches in each phase.

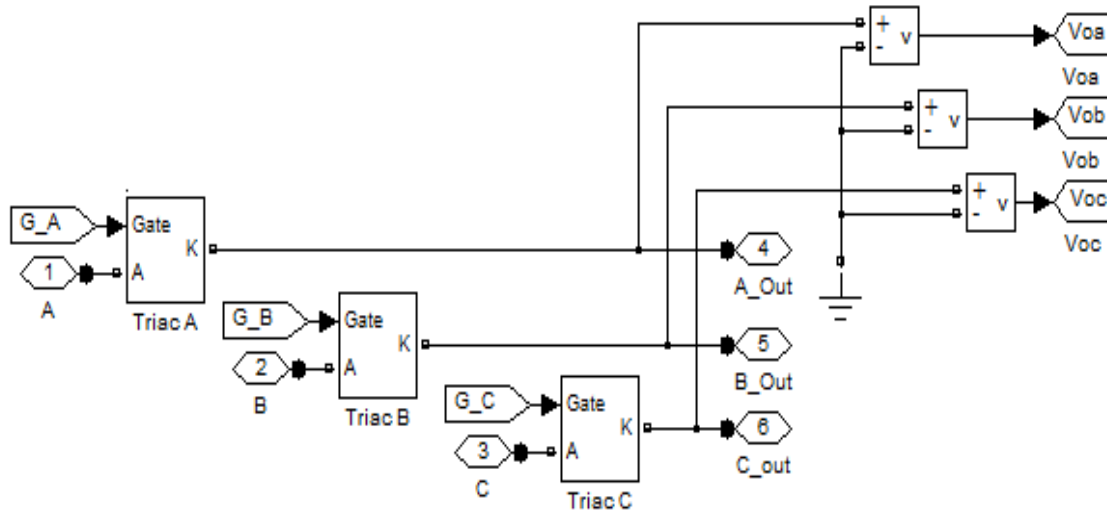

Figure 4. Electronic Switches Model

To control the amount of flow that entering to the transfer of the dummy load, then it takes a controller, The controller in this paper uses fuzzy logic control. Fuzzy logic control generates a reference signal for the opening of the gate at the TRIAC. Here is a figure block diagram of the fuzzy controller design.

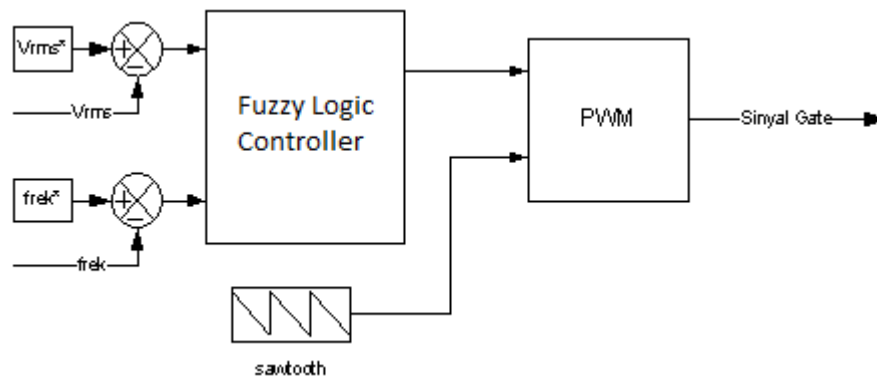

Figure 5. Fuzzy Logic Control System Model

From the Figure 5, controller fuzzy logic is given an input from the difference (error) values voltage and frequency. Voltage error value is obtained by calculating the difference between the reference voltage with the measurable voltage or actual. The value of voltage that used is the value of rmsvoltage. Frequency error value is obtained by calculating the difference between the reference frequency with the measurable frequency. Two defects will be managed by the fuzzy logic controller to generate the reference value duty cycle. Rated duty cycle will be compared to the carrier signal in the form of a triangular signal. The results of the comparison two signals, producing a signal in the form of pulses (PWM). Furthermore, this signal will be connected to the gate of the electronic switch TRIAC component.

Part of the fuzzy controller input, comprises 4 parts, namely the error voltage on phase A, phase B, phase C and error frequency value. Membership function of each part input, using triangle function that consists of 5 grades of membership, big negative, negatif medium (NM), negatif small (NS), zero (Z), positif small (PS), positif medium (PM), positif big (PB). The value of each input will be evaluated by a fuzzy rule to produce output decision. The next step is to get the value of the crisp from every evaluation results. This step is called defuzzyfication. In this paper, defuzzyfication method used is the center of gravity (COG). In Figure 6, shows the configuration design input and output fuzzy controller used in the control ELC.

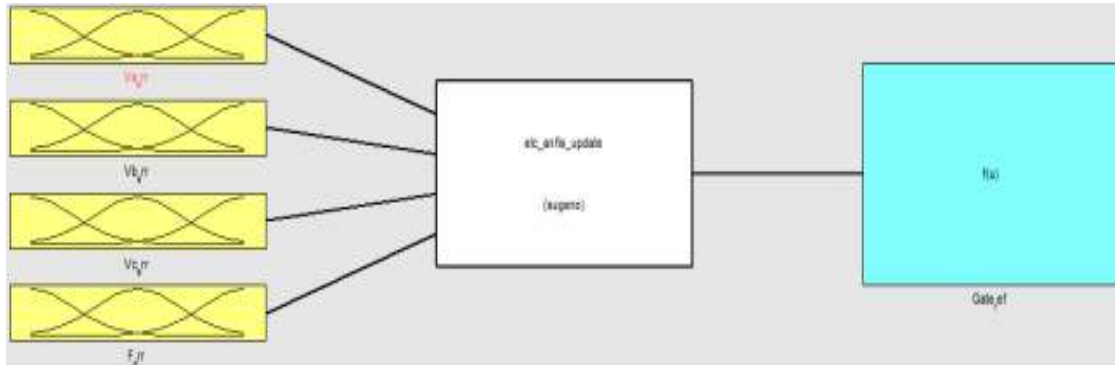

Figure 6. Design of Membership Fuzzy at ELC

3. RESULTS AND ANALYSIS

From planning system described before, then the following steps are the results of testing from models of planned system. The system was tested by changing the load power usage. The results shown in the image of voltage, duty cycle value and the current supplied to the dummy load. Because the system is considered balanced, so the voltage value and current can be represented by a single phase is phase A. Testing changes in power usage by the consumer, it do as much as ten times, with a large power drop of 250 w each time the test. The test results shown in Table 2.

Table 2 Result Testing Output Fuzzy Logic

P_load (W)	Error Freq. (Hz)	Vrms phase A (Volt)	Duty Cycle	P_dummy (W)
3500	0	0.3	-	-
3250	0.54	-8.32	0.66	250.5
3000	1.09	-15.09	0.58	495.5
2750	1.58	-22.97	0.52	751.5
2500	2.04	-42.30	0.48	1002
2250	2.49	-46.73	0.43	1250
2000	2.88	-73.14	0.38	1496
1750	3.17	-77.16	0.34	1752
1500	3.52	-97.59	0.28	1999
1250	3.95	-150.90	0.22	2250
1000	4.25	-168.10	0.001	2499

From Table 2 indicated any change in the use of power load, occurs also changes in a frequency variable and voltage. This change resulted in an error value for each variable. Value errors that occur in the process by fuzzy logic control. Fuzzy logic control generates a reference value duty cycle. Furthermore, the value of the given duty cycle will determine the current flowing to the load pseudo. Great value on the load current pseudo, proportional to the value of the power absorbed. Can be seen from the table, when the load power usage by consumers, as big as 2250 W. power absorbed by dummy load as big as 1250 W. In this case, fuzzy logic control can work effectively in determining the value of the current flowing to the dummy load. So that, the generator does not feel the change in the use of power load significantly, which can lead to changes in voltage and frequency are not that permitted. Performance wave of voltage and current test results change is shown in Figure 7 and 8 following. In Figure 7, the current testing load power consumption of 1500 W and in Figure 8, the current testing load power consumption of 3 000 W.

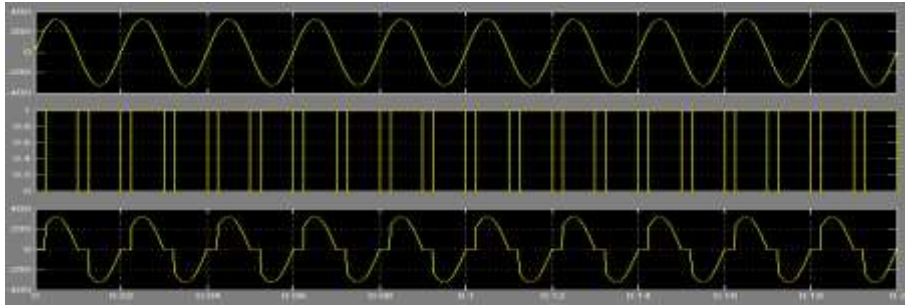

Figure 7. The main load power to 1500 W.

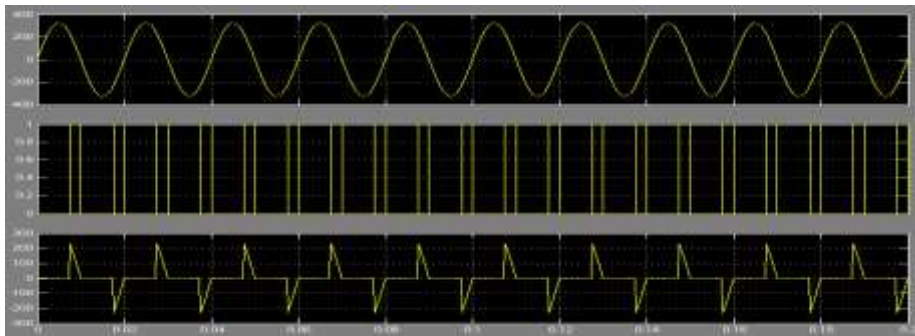

Figure 8. The main load to 3000 W.

From the 2 pictures above, the voltage value did not change significantly. Rated duty cycle greatly affect the value of the current, the greater the duty cycle value, then the value of the current flowing to the load is more greater. The following Figure 9 are shown the results of testing of changes in load power usage by using PI control and fuzzy logic control. Comparisons were made by looking at the value of the rms voltage and frequency. In the case to reach the steady state value of two variables, PI control is slower to respond to changes in voltage and frequency compared with fuzzy logic control. So it can be said that the performance fuzzy logic controller in power electronics applications that ELC, decent and has a good performance.

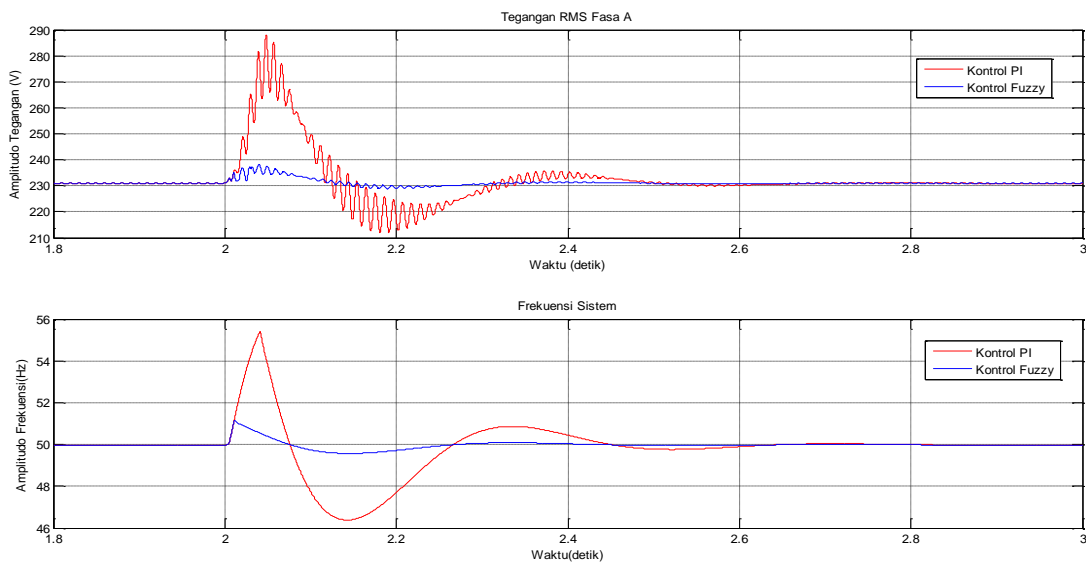

Figure 9. Comparison of response fuzzy logic control and PID

4. CONCLUSION

From the simulation of testing the performance of fuzzy logic controller on electronics circuit that ELC, can be take several conclusion is:

- a. The simulation results show that the model generator, the generator capable generate electrical power of 3 500 W and the main load also is able to absorbed the output power generator with phase voltage is 230 V.
- b. The simulation results that the electronic switch, TRIAC as a main component is able to distribute the electrical current into the dummy load accordance with value of duty cycle issued by the fuzzy logic controller.
- c. The overall result ELC base fuzzy logic controller, show better when compared with PI control, showing in quick responses the steady state conditions.

ACKNOWLEDGEMENTS

The authors wishes to express their gratitude and appreciation to the University of Muhammadiyah Malang for providing the facilities and supported for this work.

REFERENCES

- [1] ESDM, "Renewable Energy Development and Energy Conservation," in *Energy and Human Resources Development*, 2010.
- [2] A. Hasan, "Electronic Control for Microhydro Power Plant," *Power Electron. J.*, 2010.
- [3] H. Glaoui, H. Abdelkader, I. Messaoudi, and H. Saab, "Modeling of Wind Energy on Isolated Area," *Int. J. Power Electron. Drive Syst.*, vol. 4, no. 2, pp. 274–280, 2014.
- [4] M. Haddin, Soebagio, A. Soeprijanto, and M. H. Purnomo, "Modeling And Control Of Excitation And Governor Based On Particle Swarm Optimization For Micro Hydro," *TELKOMNIKA*, vol. 11, no. 2, pp. 297–304, 2013.
- [5] G. S. Rao and K. H. Reddy, "A Review on Design and Development of high Reliable Hybrid Energy Systems with Droop Control Techniques," *Int. J. Power Electron. Drive Syst.*, vol. 7, no. 3, p. 974, 2016.
- [6] F. Yusivar, N. A. Wicaksono, A. Subiantoro, and R. Gunawan, "Control of DFIG Stator Voltage on Autonomous Micro Hydro," *Int. J. Power Electron. Drive Syst.*, vol. 7, no. 2, pp. 498–508, 2016.
- [7] A. Mangal, A. Ahmed, D. Chaudhary, and M. Chauhan, "Automatic Generation Control Using SMES Anubha," *Int. J. Eng. Res. Manag. Technol.*, vol. 2, no. 3, pp. 175–186, 2015.
- [8] D. Maksimovic, A. M. Stankovic, V. J. Thottuvelil, and G. C. Verghese, "Modeling and Simulation of Power Electronic Converters," in *Proceedings of the IEEE*, 2001, vol. 89, no. 6.
- [9] K. A. Nigim, "Voltage controlled stand-alone microhydro induction generator system," *Int. J. Glob. Energy Issues*, vol. 24, pp. 100–111, 2005.
- [10] E. Mishra and S. Tiwari, "Fuzzy Logic Control based Electronic Load Controller for Self Excited Induction Generator," in *2016 International Conference on Electrical Power and Energy System (ICEPES)*, 2016, pp. 169–174.
- [11] A. Faruq, S. Shah, B. Abdullah, and M. F. N. Shah, "Optimization of an Intelligent Controller for an Unmanned Underwater Vehicle," *Telkonnika*, vol. 9, no. 2, pp. 245–256, 2011.
- [12] A. Faruq, S. S. Abdullah, M. Fauzi NS, "Optimization of depth control for Unmanned Underwater Vehicle using surrogate modeling technique," *2011 Fourth Int. Conf. Model. Simul. Appl. Optim.*, pp. 1–7, 2011.

BIBLIOGRAPHY OF AUTHORS



Muhammad Irfan was born in Mojokerto, Indonesia in 1966. He graduated with Bachelor of Informatics Engineering from Sepuluh Nopember Technological Institute (ITS), Surabaya. His Master was also from the same institute gradated on 2000. Currently he is a senior lecturer in Electrical Engineering Department University of Muhammadiyah Malang (UMM) and active members of Research and Development Institute of UMM. His area of interest is Electrical Power Engineering, Power Electronics & Drive, Digital Signal Processing and Energy Efficiency.



Machmud Effendy was born in Malang, Indonesia in 1974. He graduated with Bachelor of Electrical Engineering from University of Muhammadiyah Malang (UMM). He did a Master degree from University of Gadjah Mada (UGM) Yogyakarta, Indonesia in the field of Micro hydro power plant. Currently his activity as a Lecturer in Electrical Engineering Department, UMM. Micro hydro power plant, sustainable energy is the interested research for him.



Nur Alif Mardiyah passed her Bachelor and Master degree in Electrical Engineering area from University of Brawijaya and University of Indonesia respectively. Currently she as senior lecturer in EE Dept of UMM. Electronic and Digital Signal Processing are her interested things of research activities for her.



Lailis Syafaah has passed her Bachelor and Master degree in Electrical Engineering from Sepuluh Nopember Technological Institute (ITS). She has successfully done her Doctoral program for Medical Electronic from University of Brawijaya. Currently she as senior lecturer in EE Dept UMM and actively doing research for Electrical Engineering, Sustainable Energy and Medical Electronic.