

The FHA Analysis of Dual-Bridge LLC Type Resonant Converter

Arnold Fredderics*, K.Vinoth Kumar*, A.Shankar*, Jeya Selvan Renius*, Raja Guru*
Sree Lakshmi Nair*, K.Viswanathan**

* Department of Electrical and Electronics Engineering, School of Electrical Sciences,
Karunya Institute of Technology & Sciences University, Coimbatore – 641114, Tamilnadu, India

** Department of Electrical and Computer Engineering, School of Engineering,
Adama Science and Technology University, Ethiopia

Article Info

Article history:

Received Jul 27, 2014

Revised Sep 13, 2014

Accepted Oct 5, 2014

Keyword:

Dc-dc converter

Resonant converter

Zero voltage switching

ABSTRACT

The dual bridge resonant converter is designed in this paper. In this converter the LLC type resonance configuration is proposed. This types is compared with the other configurations and its benefits are narrated in this paper. The steady-state analysis of the LLC configuration is done using fundamental harmonics approximation method and the values for the components of resonance configuration is found and used for simulation. The simulation results shows that the converter is able to achieve the zero voltage switching for the wide load range and attains a good efficiency.

*Copyright © 2014 Institute of Advanced Engineering and Science.
All rights reserved.*

Corresponding Author:

Arnold Fredderics A,
Department of Electrical and Electronics Engineering,
School of Electrical Sciences, Karunya University,
Coimbatore – 641114, Tamilnadu, India.
Email: arnoldfredderics@gmail.com

1. INTRODUCTION

Nowadays, the renewable energy generation plays a vital part in power generation. Many new techniques are evolving to get better output efficiency from the renewable energy system. As the renewable energy is fluctuating it cannot produce the expected output. So, the power converters play a major role in renewable energy power generation system [1], [4]. In the hybrid renewable energy generation system that use wind, solar, tidal and that are coupled with dc, is common to use bi-directional dc-dc converter to interface dc bus with battery storage stack. In dual active bridge converter, the zero voltage switching control can be achieved easily [2], but to achieve it for a wide load range the voltage gain of that converter should be maintained to unity. So the resonance version of that converter is used to achieve a ZVS for a wide load range [3]. The voltage and current of the dual bridge resonant converter are nearly sinusoidal, so that the lower order harmonics and the filter size is small. There are mainly two types of resonance converter, one is series resonance and another one is parallel resonance circuit. Each configuration has its limitations that are discussed in this paper further, so the hybrid –resonant converter topology is proposed which is a one of the types of voltage – source series resonant converters .The benefits of using the hybrid topology is narrated in the later sections of this paper. Among the hybrid topology the LLC type dual- bridge resonant converter is proposed and its zvs operation for a wide load range is verified using simulation results. The values for the resonance components are found using the FHA design and implemented in the simulation. The block diagram of the operation performed by the proposed method is shown below.



Figure 1. Block diagram of the proposed topology

The square wave generator has two switches that converts the dc input to a ac output. The ac output is in the shape of square wave. This square wave is given to the resonant circuit, and given to rectifier circuit. There are conventional methods in resonant converters, they are discussed and their limitations are shown. Their limitations are rectified using this proposed topology. The proposed topology is a type of load resonant converter, and it is named as hybrid resonant converter. As the name denotes, the proposed topology has the combination of both series and parallel resonant converter. This hybrid resonant converter has two major topologies, one of that is LCC resonant converter and another one is LLC resonant converter. Among the two topologies, our proposed method comes under the LLC type resonance converter. Hence, in this paper we relate the limitations of various conventional resonant converters between the proposed topology. And the proposed converter satisfies the condition of achieving ZVS for the whole load range, are found using simulation results. The resonant component values are analyzed using FHA method and applied for simulation, to reduce the voltage stress.

2. CONVENTIONAL CONVERTERS

There are many resonant-converter topologies, and they all operate in essentially the same way. A square pulse of voltage or current generated by the power switches is applied to a resonant circuit. Energy circulates in the resonant circuit, and some or all of it is then tapped off to supply the output. Among resonant converters, two basic types are the series resonant converter (SRC), shown in Figure 2(a), and the parallel resonant converter (PRC), shown in Figure 2(b). Both of these converters regulate their output voltage by changing the frequency of the driving voltage such that the impedance of the resonant circuit changes.

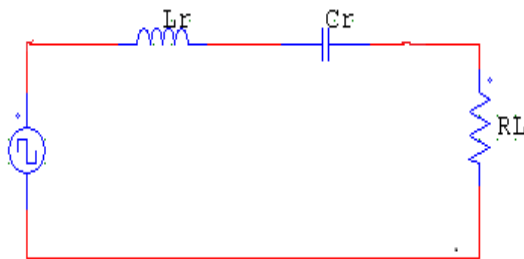

Figure 2(a). Series resonant converter

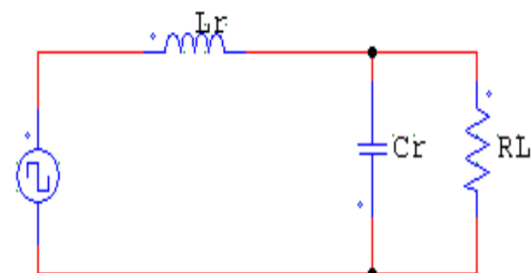

Figure 2(b). Circuit diagram of parallel resonant converter

2.1. Series Resonant Converter

The series resonant converter has the inductor and capacitor arranged in series to the load. This dual-bridge series resonant converter has inherent limitation of ZVS operation for variation in load and input/output voltages. In reported works, LLC-type resonant tank has been proved useful for extend ZVS range for conventional fixed-frequency resonant converter with small component stress [5].

The input voltage is split between this impedance and the load. Since the SRC works as a voltage divider between the input and the load, the DC gain of an SRC is always lower than 1. Under light-load conditions, the impedance of the load is very large compared to the impedance of the resonant circuit; so it becomes difficult to regulate the output, since this requires the frequency to approach infinity as the load approaches zero. Even at nominal loads, wide frequency variation is required to regulate the output when there is a large input-voltage range.

2.2. Parallel Resonant Converter

The parallel resonant converter has the inductor and capacitor arranged in parallel to the load. The circuit diagram of the parallel resonant converter is shown below. The load is connected in parallel with the resonant circuit, inevitably requiring large amounts of circulating current. This makes it difficult to apply parallel resonant topologies in applications with high power density or large load variations.

The inductor is denoted as L_r and the capacitor is denoted as C_r . The load is denoted as R_L .

3. EXISTING TOPOLOGY

To overcome the limitations of the conventional converters, the existing topology is designed with the combination of both series and parallel converter combinations. In this it has two divisions, one is LCC resonant converter and another one is the LLC resonant converter topology. The brief description of these converters is as follows.

3.1. LCC Resonant Converter

To solve these limitations, a converter combining the series and parallel configurations, called a series-parallel resonant converter (SPRC) has been proposed. One version of this structure use one inductor and two capacitors, or an LCC configuration, as shown in Figure 3(a). Although this combination overcomes the drawbacks of a simple series resonant converter or parallel resonant converter by embedding more resonant frequencies, it requires two independent physical capacitors that are both large and expensive because of the high AC currents. So the physical capacitors are the limitations of these LCC type resonant converters.

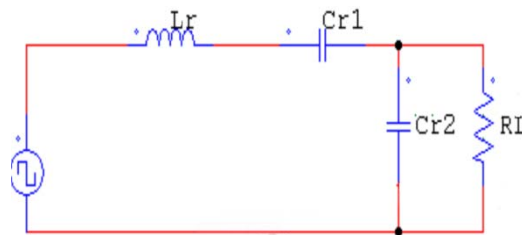

Figure 3(a). LLC type resonant converter

In this the capacitors are connected in parallel, with the inductor in series, C_{r1} and C_{r2} are the capacitors, L_r is the inductor.

3.2. LLC Resonant Converter

To get similar characteristics without changing the physical component count, the SPRC can be altered to use two inductors and one capacitor, forming an LLC resonant converter Figure 3(b). An advantage of the LLC over the LCC topology is that the two physical inductors can often be integrated into one physical component, including both the series resonant inductance, L_r , and the transformer's magnetizing inductance, L_m . The LLC resonant converter has many additional benefits over conventional resonant converters. For example, it can regulate the output over wide line and load variations with a relatively small variation of switching frequency, while maintaining excellent efficiency. It can also achieve zero voltage switching (ZVS) over the entire operating range.

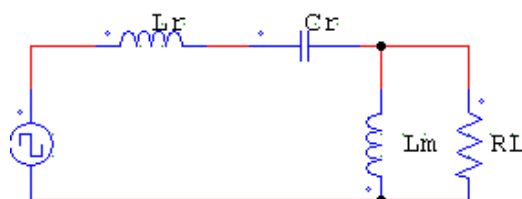

Figure 3(b). LLC type resonant converter

Using the LLC resonant configuration in an isolated half-bridge topology will be described next, followed by the modifications in it for the new proposed topology.

3.3. Hybrid Resonant Converter

This resonant converter circuits comes under load resonant converters. In this converter circuits the power flow to the load is controlled by the resonant tank impedance which in turn is controlled by the switching frequency in comparison to the resonant frequency of the tank. This hybrid resonant converter is a voltage- source series resonant converter. The Figure 3(c) shows the circuit of hybrid resonant converter topology.

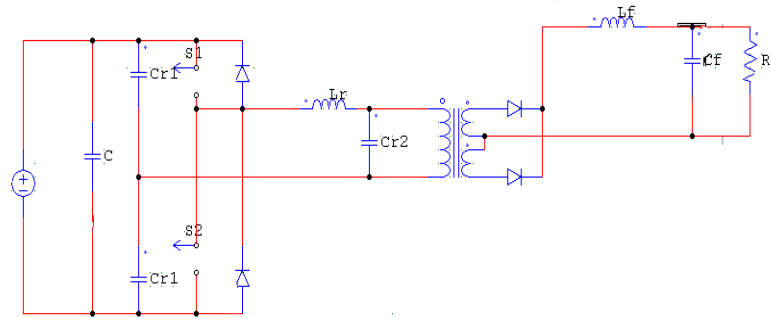

Figure 3(c). Circuit diagram of hybrid resonant converter topology

4. PROPOSED TOPOLOGY

The modifications done in the hybrid resonant converter topology gives us the new converter topology in which the zero voltage switching can be achieved throughout the load range. That in turn reduces the voltage stress across the switches. From the existing topology the switches are replaced with power MOSFET on the primary side and on the secondary side the diodes are replaced with power MOSFET. The converter configuration in Figure 4(a) has three main parts:

a) Power switches S1 and S2, which are usually MOSFETs, are configured to form a square wave generator. This generator produces a unipolar square-wave voltage, V_{sq} , by driving switches S1 and S2, with alternating 50% duty cycles for each switch. A small dead time is needed between the consecutive transitions, both to prevent the possibility of cross conduction and to allow time for ZVS to be achieved.

b) The resonant circuit, also called a resonant network, consists of the resonant capacitance, C_r , and two inductances—the series resonant inductance, L_r , and the transformer magnetizing inductance, L_m . The transformer turns ratio is n . The resonant network circulates the electric current and, as a result, the energy is circulated and delivered to the load through the transformer. The transformer's primary winding receives a bipolar square-wave voltage. This voltage is transferred to the secondary side, with the transformer providing both electrical isolation and the turns ratio to deliver the required voltage level to the output.

c) The secondary side has the replacement of diodes with the power MOSFETs; this makes the rectifiers to perform synchronous rectification to reduce conduction losses, especially beneficial in low-voltage and high current applications.

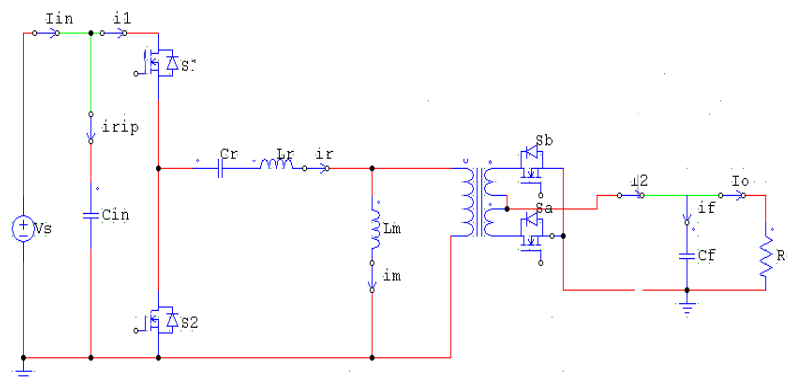

Figure 4(a). Circuit diagram of the proposed converter

4.1. Basic Procedure for FHA analysis

The LLC converter is operated in the vicinity of series resonance. This means that the main composite of circulating current in the resonant network is at or close to the series resonant frequency. This provides a hint that the circulating current consists mainly of a single frequency and is a pure sinusoidal current. Although this assumption is not completely accurate, it is close-especially when the square Wave's switching cycle corresponds to the series resonant frequency. If the square wave is different from the series resonance, then in reality more frequency components are included; but an approximation using the single fundamental harmonic of the square wave can be made while ignoring all higher order harmonics and setting possible accuracy issues aside for the moment. This is the so-called first harmonic approximation (FHA) method, now widely used for resonant-converter design. This method produces acceptable design results as long as the converter operates at or close to the series resonance. The FHA method can be used to develop the gain, or the input-to-output voltage-transfer function. The first steps in this process are as follows:

- Represent the primary-input unipolar square wave voltage and current with their fundamental components, ignoring all higher-order harmonics.
- Ignore the effect from the output capacitor and the transformer's secondary-side leakage inductance.
- Refer the obtained secondary-side variables to the primary side.
- Represent the referred secondary voltage, which is the bipolar square-wave voltage (V_{so}), and the referred secondary current with only their fundamental components, again ignoring all higher-order harmonics.

With these steps accomplished, a circuit model of the LLC resonant half-bridge converter can be obtained. In the circuit model, both input voltage and output voltage are in sinusoidal form with the same single frequency-i.e., the fundamental component of the square wave voltage, generated by the switching operation of S1 and S2. This model is called the resonant converter's FHA circuit model. Assumptions for the analysis are, all inductors, capacitors, diodes, switches, the HF transformer are assumed to be ideal.

To facilitate the calculation, all quantities would be normalized by the following base values.

$$V_B = V_s/2; Z_B = \sqrt{(L_r/C_r)}; I_B = V_B/Z_B;$$

The normalized switching frequency is:

$$F = \omega_s/\omega_r; \quad \omega_s = 2\pi f_s; \quad \omega_r = 2\pi f_r.$$

The normalized reactance of the resonant tank:

$$XL_{r,pu} = F; \quad XC_{r,pu} = 1/F; \quad XL_{m,pu} = F/L_n;$$

The series parallel inductance ratio is $L_n = L_r/L_m$.

The normalized fundamental primary output voltage:

$$vr_{1,pu}(t) = \sqrt{2} Vr_{1,pu} \sin \omega_s t$$

$$Vr_{1,pu} = \sqrt{8/\pi}, \text{ is the normalize rms voltage.}$$

$$vr_{1,pu}(t) = \frac{4}{\pi} \sin \omega_s t.$$

The normalized fundamental component of voltage across the high-frequency transformer is,

$$vt_{1,pu}(t) = \sqrt{2} (Vt_{1,pu} \sin \omega_{st} - \phi) = \frac{4M}{\pi} \sin \omega_{st} - \phi, \phi \text{ is the controlled phase shift.}$$

$$Vt_{1,pu} = \sqrt{8M/\pi}, \text{ fundamental rms component is the normalized.}$$

M, is the normalized converter voltage gain,

$$M = \frac{V'_0}{V_B}; \quad n_t = V'_0/V_0 = 2n_t V_0/V_s$$

$$\text{The quality factor is } Q = \frac{Z_B}{\frac{8n^2 R_0}{\pi^2}} = \pi^2 Z_B P_0 / 8n^2 V_0^2$$

It forms the basis for the analysis and finally the values for the components are found and applied for this proposed topology and it is checked using PSIM simulation. The results shows that the resonance components' value makes the converter topology to achieve 80% of efficiency. This analysis can be done for different converter topologies [6], [7].

5. SIMULATION CIRCUIT

The simulation is done using the values obtained by the FHA analysis. The simulation tool used is PSIM. The simulation circuit and the waveforms of the gating signals, voltage across the capacitor, output voltage, ZVS across the switch are also shown in Figure 5 (a)-(f). The input voltage is 200V; the expected output voltage is nearly 48V. The voltage across the capacitors should be 200V. The transformers turn ratio is kept at 25:12:12. The resistor is connected on the primary side in series with the source, to reduce the current; this is done during the simulation. The value of the capacitance can be varied to get different outputs. The leakage inductance of the transformer plays a major role. So, to get a smooth output the value of the leakage inductance can be changed.

ZVS operation can be confirmed by checking the phase angles of i_r and i_t with respect to v_r and v_t , respectively. For same output power, the output current i_2 shows less negative percentage at 40 V output than 48 V output. The above mentioned v_r and v_t are the voltages of primary and secondary sides respectively.

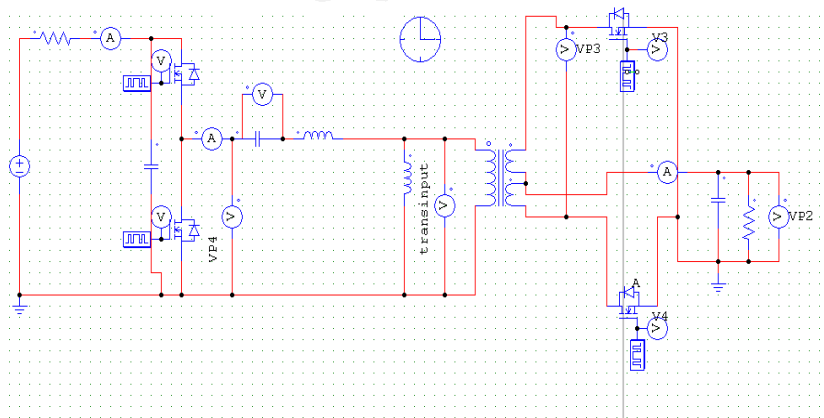

Figure 5(a). Simulation circuit of proposed converter

The waveforms for the gating signals of the switches on the primary side S1 and S2 are shown in Figure 5(b).

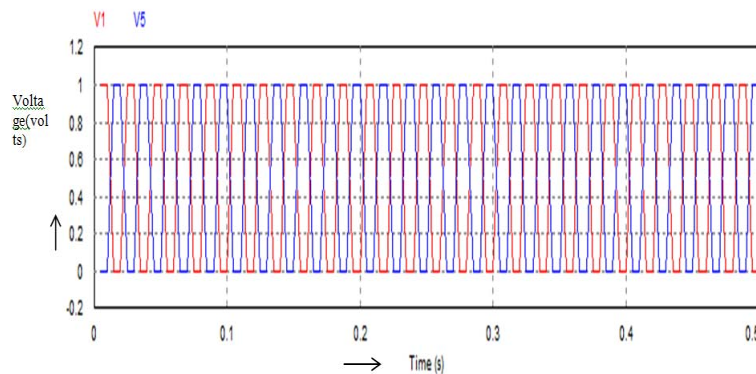

Figure 5(b). The waveforms of gate signals of switch S1 and S2

The waveforms of the gating signals of the switches on the secondary side is shown in the Figure 5(c).

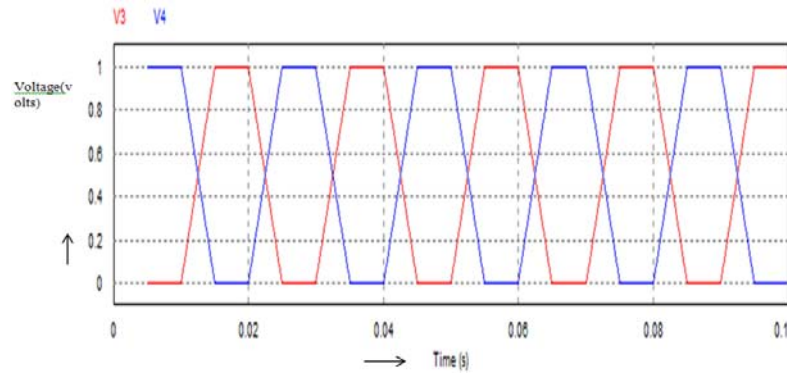

Figure 5(c). The waveforms of the gating signals for the secondary side switches

The capacitor (C_r) in the resonance block should have the voltage of 200V, and its simulation waveform is shown in the Figure 5(d).

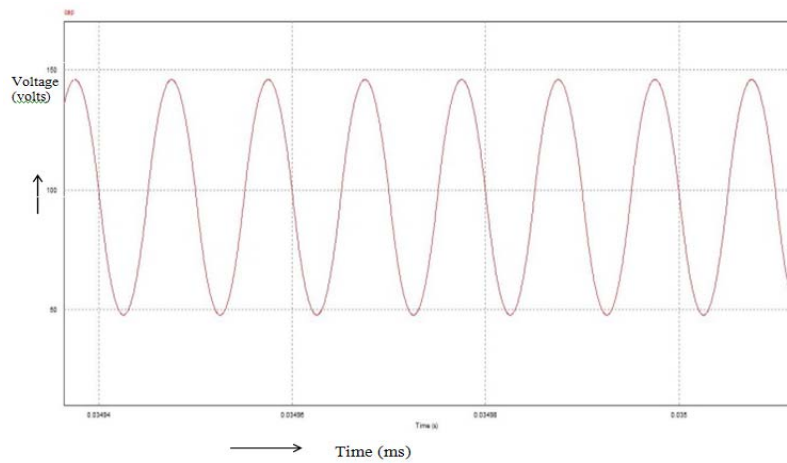

Figure 5(d). The waveform for the capacitor voltage (V_{cr})

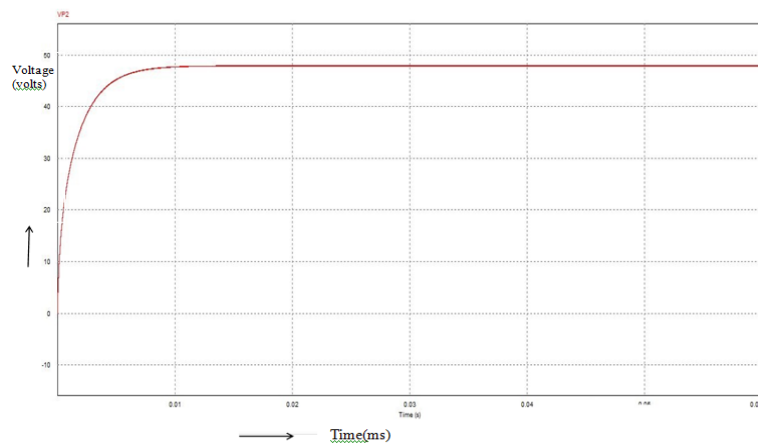

Figure 5(e). The wave form of output voltage of proposed converter

The output from the secondary side is measured in Vp2 of the simulation diagram, and the expected result should be 48V. The waveform for the output voltage is shown in the Figure 5(e). The FHA analysis is done to find the values of the components that can be applied to the proposed converter topology, so that the ZVS is achieved for the whole load range, if it is attained, the output voltage should be around 48V, even though there is variation in switches and load. The values that are obtained from the analysis and applied in the simulation are Lr: 165.39 μ H; Cr: 25mF; Lm: 159.3 μ H.

6. CONCLUSION

The LLC type dual-bridge resonant converter is analyzed with various other conventional topologies and the basic analysis procedure is done using FHA analysis. And the results are used for simulation and verified. The results of the simulation show that this proposed topology, maintains zero voltage switching for various switches for all the load range, without any voltage stress for the switches. The converter maintains the efficiency of 80%, for whole load range. The future work is based on the gating schemes for the switches that can reduce the amount of circulating current, and to increase the overall efficiency of the converter.

REFERENCES

- [1] JT Bialasiewicz. Renewable energy systems with photovoltaic power generator: Operation and modeling. *IEEE Transactions on Industrial Electronics*. 2008; 55(7): 2752–2758.
- [2] RW De Doncker, DM Divan, MH Kheraluwala. A three-phase soft-switched high power density DC/DC converter for high power applications. *IEEE Transactions on Industrial Applications*. 1991; 27(1): 63–73.
- [3] XD Li, AKS Bhat. Analysis and design of high-frequency isolated dual-bridge series resonant dc/dc converter. *IEEE Transactions on Power Electronics*. 2010; 21(2): 850–862.
- [4] JM Carrasco et al. Power electronics systems for the grid integration of renewable energy sources: A survey. *IEEE Transactions on Industrial Electronics*. 2006; 53(4): 1002–1016.
- [5] AKS Bhat. *Analysis and design of a fixed-frequency LCL-type series resonant converter with capacitive output filter*. IEEE Proceedings Circuits Devices System. 1997; 144(2): 97–103.
- [6] I Batarseh. Resonant converter topologies with three and four energy storage elements. *IEEE Transactions on Power Electronics*. 1994; 9(1): 64–73.
- [7] AKS Bhat, SB Dewan. A generalized approach for the steady state analysis of resonant inverters. *IEEE Transactions on Industrial Applications*. 1989; 25(2): 326–338.
- [8] GG Oggier, M Ordonez, JM Galvez, F Luchino. Fast transient boundary control and steady-state operation of the dual active bridge converter using the natural switching surface. *IEEE Transactions on Power Electronics*. 2014; 29(2): 946–957.
- [9] XD Li, A Rathore. A general study of soft-switching ranges of dual-bridge resonant converters using a modified complex AC analysis approach. *Proceedings IEEE 6th Conference Industrial Electronics Applications*, Beijing, China. 2011: 316–321.

BIOGRAPHIES OF AUTHORS



Mr. A. Arnold Fredericks received his B.Tech. degree in Electrical and Electronics Engineering from Anna University, Tamilnadu, India. Presently he is pursuing M.Tech in Power Electronics and Drives from Karunya University, Coimbatore, Tamil Nadu, India. His present research interests are Power converters, Special machines, Solar Application.



Prof. K. Vinoth Kumar received his B.E. degree in Electrical and Electronics Engineering from Anna University, Chennai, Tamil Nadu, India. He obtained M.Tech in Power Electronics and Drives from VIT University, Vellore, Tamil Nadu, India. Presently he is working as an Assistant Professor in the School of Electrical Science, Karunya Institute of Technology and Sciences (Karunya University), Coimbatore, Tamil Nadu, India. He is pursuing PhD degree in Karunya University, Coimbatore, India. His present research interests are Condition Monitoring of Industrial Drives, Neural Networks and Fuzzy Logic, Special machines, Application of Soft Computing Technique. He has published various papers in international journals and conferences and also published four textbooks. He is a member of IEEE (USA), MISTE and also in International association of Electrical Engineers (IAENG).



Prof. Shankar. A received his B.E. degree in Electrical and Electronics Engineering in DMI college of engineering from Anna University, Chennai, Tamil Nadu, India. He obtained M.Tech in Power systems from kalasalingam university University, madurai, Tamil Nadu, India. Presently he is working as an Assistant Professor in the School of Electrical Science, Karunya Institute of Technology and Sciences (Karunya University), Coimbatore, Tamil Nadu, India. He is pursuing PhD degree in Karunya University, Coimbatore, India. His present research interests are nano structured pv cells, smart grid implementation and reliability analysis in renewable energy generators.



Mr. A. Jeya Selvan Renius received his B.Tech. degree in Electronics and Communication Engineering from Anna University, Tamilnadu, India. Presently he is pursuing M.Tech in Power Electronics and Drives from Karunya University, Coimbatore, Tamil Nadu, India. His present research interests are Power converters and inverters, Special machines, Solar and wind Applications.



Mr. B. Raja Guru received his B.Tech. degree in Electronics and Communication Engineering from Anna University, Tamilnadu, India. Presently he is pursuing M.Tech in Power Electronics and Drives from Karunya University, Coimbatore, Tamil Nadu, India. His present research interests are Resonant converters, Special machines, Solar Application.



Ms. Sreelakshmy Nair received his B.Tech. degree in Electrical and Electronics Engineering from Saintgits college of engineering, Mahatma Gandhi University, Kerala, India. Presently she is pursuing M.Tech in Power Electronics and Drives from Karunya University, Coimbatore, Tamil Nadu, and India. Her present research interests are dc-dc converters and inverters.



Prof. Viswanathan Kreceived his B.E. degree in Electrical and Electronics Engineering in Government College of Technology, Coimbatore, Tamil Nadu, India. He obtained M.E in Power System Engineering from Government College of Technology, Coimbatore, Tamil Nadu, India. Presently he is working as an Assistant Professor in the School of Engineering, Adama Science & Technology University, Adama, Ethiopia. He is pursuing PhD degree in St.Peters University, Chennai, India. His present research interests are Power Systems, Renewable Energy sources and Electrical Machines.