

Destination Image of Tourist: Effect of Travel Motivation and Memorable Tourism Experience

Dani Dagustani¹, Dwi Kartini², Yevis Marty Oesman³, Umi Kaltum⁴

Abstract. *The eco-tourism area of the southern coast of West Java is the focus of research since the area is less well known as a tourist destination. Also, there is a reluctance of tourists to visit again, and tourists find ordinary. The purpose of this study is to examine the influence model of travel motivation and impressive tourism experience towards the destination image. The method used is verification analysis by using Structural Equation Model (SEM). The survey conducted on 302 respondents, i.e., tourists who visited the eco-tourism area of the southern coast of West Java. The results showed the motivation of travel and tourism experience significantly influence the image of tourism destinations. Tourism area managers need to design strategies to improve the image of the region by providing tourist stimulation in the form of exciting information and offers eco-tourism products-themed for tourist with a memorable approach to traveling experiences.*

Keywords: *travel motivation, memorable tourism experience, destination image*

Abstrak. *Kawasan eko wisata pantai selatan Jawa Barat menjadi fokus penelitian, karena kawasan ini kurang dikenal sebagai daerah tujuan wisata rendah. Selain itu terdapat keengganan wisatawan untuk berkunjung kembali dan wisatawan tidak menemukan hal unik. Tujuan penelitian ini menguji model pengaruh motivasi perjalanan wisata dan pengalaman pariwisata mengesankan terhadap Citra destinasi. Metode yang digunakan adalah analisis verifikatif dengan menggunakan Structural Equation Model (SEM). Survey dilakukan terhadap 302 responden yaitu wisatawan yang berkunjung ke kawasan eko wisata pantai selatan Jawa Barat. Hasil penelitian menunjukkan motivasi perjalanan wisata dan pengalaman pariwisata berpengaruh signifikan terhadap Citra destinasi pariwisata. Pengelola kawasan wisata perlu merancang strategi peningkatan citra kawasan dengan memberikan rangsangan wisata berupa informasi yang menarik dan menawarkan produk wisata bertema eko wisata dengan pendekatan pengalaman berwisata yang berkesan.*

Kata kunci: *motivasi perjalanan, pengalaman pariwisata mengesankan, citra destinasi*

How to Cite:

Dagustani, D., Kartini, D., Oesman, Y. M., & Kaltum, U. (2018). Destination Image of Tourist: Effect of Travel Motivation and Memorable Tourism Experience. *Etikonomi: Jurnal Ekonomi*. Vol. 17 (2): 307 – 318. doi: <http://dx.doi.org/10.15408/etk.v17i2.7211>.

Introduction

The contribution of tourism to GDP continues to increase in line with Indonesia's economic growth. Crucial other tourism indicators such as the amount of GDP, the foreign exchange, the visits of foreign tourists and the movement of domestic tourists showed a steadily increasing performance. In 2016, tourism contribution to GDP is about 4.03% or equivalent to IDR 500.19 trillion, and the foreign visitor reached 12.02 million foreign tourists with the acquisition of 13 billion USD foreign exchange. In 2019, it projected that the tourism sector would become the first foreign exchange contributor in Indonesia (Ministry-Of-Tourism, 2016). Given the current objective conditions and future growth projections, the future of the tourism industry has an excellent opportunity, but it all depends on the stakeholders in the tourism industry itself in seizing the world and national tourism market.

West Java province has many potential tourist destinations and tourist attraction. This research is part of the dissertation, and it focused on the eco-tourism area of Apra Beach - Cipatujah on the south coast of West Java province which stated in the Master Plan of Tourism Development of West Java Province in 2015-2025. Then this area is called the eco tourist area of the southern coast of West Java. The level of the visit in this area is relatively little when it compared to the visits of another strategic tourism area in West Java. The visit contribution of eco tourism area on the south coast of West Jawa is only about 8.6% to total tourist visit to West Jawa.

The Causes of low tourist visits include the image of the area that is less good in the point of view of tourists, especially on accessibility to the region, in the form of inadequate road infrastructure and public transportation to the region. The image of the tourism destination itself has two components, namely cognitive which refers to the belief and knowledge of the evaluation result on the attribute of destination and useful in the form of an emotional element which refers to the value attached to the destination related to motivation (Pratminingsih et al., 2014). Another opinion put forward by Zhang et al. (2017) the image of destinations as the core of tourism products related to tourist attractions and tourism facilities that directly relate to the core of tourist needs. The relation of tourism travel motivation and the memorable tourism experience to the image of tourism destinations can explain as follows. A series of destination shape the image of tourism destinations attributes that are influenced by the personal characteristics of the individual or internal factors such as existing motivations, impressions, beliefs, opinions, preference of product, knowledge, which continues to be accumulated from various memorable tourism experiences on the image attributes of tourism destinations (Kim and Chen, 2016).

The main selling point of tourism products is the creation of tourism experience. It is natural that everything the tourists feels in their destinations is an experience (Oh et al., 2007). At the time the consumers are not entirely satisfied with the products, services or brands, they want a mix of experience and something that is very exciting, experience makes a high emotional expression rather than a satisfaction association (Rageh and Melewar, 2013). Theories of memorable tourism experience originate from the influence of memory power when making decisions on tourist destinations, some experts say that the importance of past

memory as a single source of information when tourists will decide to make a return visit to the primary destination (Chandralal et al., 2015; Chandralal and Valenzuela, 2013). Kim et al. (2012) developed an impressive scale of tourism experience measurement (Memorable Tourism Experience). The result of research is seven dimension of forming Memorable Tourism Experience that is hedonism, Novelty, local culture, refreshing, meaningfulness, involvement, and knowledge. In this research included dimension Improvement of social relationships as new dimension appropriate to Indonesian tourists behavior. The relation of Memorable Tourism Experience variables to the re-visit intentions supported by research from Chang et al. (2014) Kim et al. (2010), Tsai (2016), and Zhang et al. (2017).

Ritchie et al. (2011) conducted a study of articles published in significant tourism paper from 2000 to 2010. Out of 2645 articles, only 263 articles focused on the experiential tourism or 9.9% of the total publications. Based on this, there is indeed a need for deepening the tourism marketing research mainly on the tourism experience.

From the previous two concepts of revisit intention and memorable experience during the tour, it is essential for the eco-tourism managers of the southern coast of West Java to know about what encourages tourists to visit a destination because the drive for a vacation arises from the need for something that can fulfill from traveling. The approach to this phenomenon is the travel motivation as it is a fundamental factor in knowing the tourist's behavior.

Chang et al. (2014) argue that the travel motivation interpreted as a force of encouragement that motivates tourists to go sightseeing or revisit the tourist destinations. Another view of the tourism destinations, understanding the motivation of tourists results in the ability to increase the level of pleasure or the sense of tourists enjoyment, so it will be better in maintaining the loyalty of tourists, or behavior to visit again (Pratminingsih et al., 2014). The influence of travel motivation to the destination image supported by previous research such as Chang et al. (2014), Khan et al. (2017), Kim and Chen (2016), Pratminingsih et al. (2014), Prayag and Ryan (2011).

This research becomes a novelty to develop tourism product based on memorable tourism experience that is in line with the characteristics of Indonesian tourists who started the tourists' segmentation based on motivation in order to improve the destination image.

Method

The type of research design used is verification research (causal) in order to test the truth of all hypothesis or relationship which executed through formal and structured data collection. Causality research aims to gain the explanation of causality between several concepts or some variables developed in management (Cooper and Schindler, 2014; Ferdinand, 2014).

The unit of analysis in this study are tourists who visit the eco-tourism area of the southern coast of West Java. The sampling did by selecting the tourism beach used as sampling place by cluster sampling method. The selected beaches are Santolo beach, Sayang Heulang beach, Ranca Buaya beach and Cipatujah beach. The sampling of tourists in each beach is done proportionally with systematic sampling technique. The sample size used refers to

(Sekaran and Bougie, 2016) which explains that in the multivariate studies, the sample size should be ten times greater than the number of parameters measured in the study, so with 24 parameters, 302 will used as samples.

Questionnaires for the survey divided into three variables: 1) The travel motivation (MO) has seven dimensions: MO1, interaction facilities, MO2, Nostalgic and looking for a simpler life, MO3, rest and relaxation, MO4, Achievement, MO5, Breakout from routine, MO6, Self-Evaluation, MO7, Viewing tourist attractions and adventures. 2) Memorable tourism experience (EXP) has nine dimensions of EXP1, Hedonism, EXP2, Novelty, EXP3, Local Culture, EXP4, Refreshment, EXP5, Meaning, EXP6, Involvement, EXP7, Knowledge, EXP8, Bad feelings and EXP9, Improvement of social relationships. 3) Destination image (CD) with eight dimensions CD1, destination environment, CD2, natural attraction, CD3, Opportunities for adventure tourism, CD4, tourism and its support facilities, CD5, Accessibility, CD6, Entertainment and events, CD7, Price and value, CD8, Affective. Dimensional measurement variables refer to previous research by Chi and Qu (2008), Kim (2014, 2017), Kim et al (2012), Lertputtarak (2012), Shi et al (2012), Sthapit and Coudounaris (2018), Yoon and Uysal (2005), Zhang et al (2017), Zhang and Peng (2014).

Data analysis performed using Structural Equation Modeling (SEM) which is a statistical technique used to test a series of relationships between several variables. The structural model of this research can see in Figure 1.

Figure 1. Structural Models of The Influence of Traveling Motivation and Memorable Tourism Experiences Towards Revisit Intention

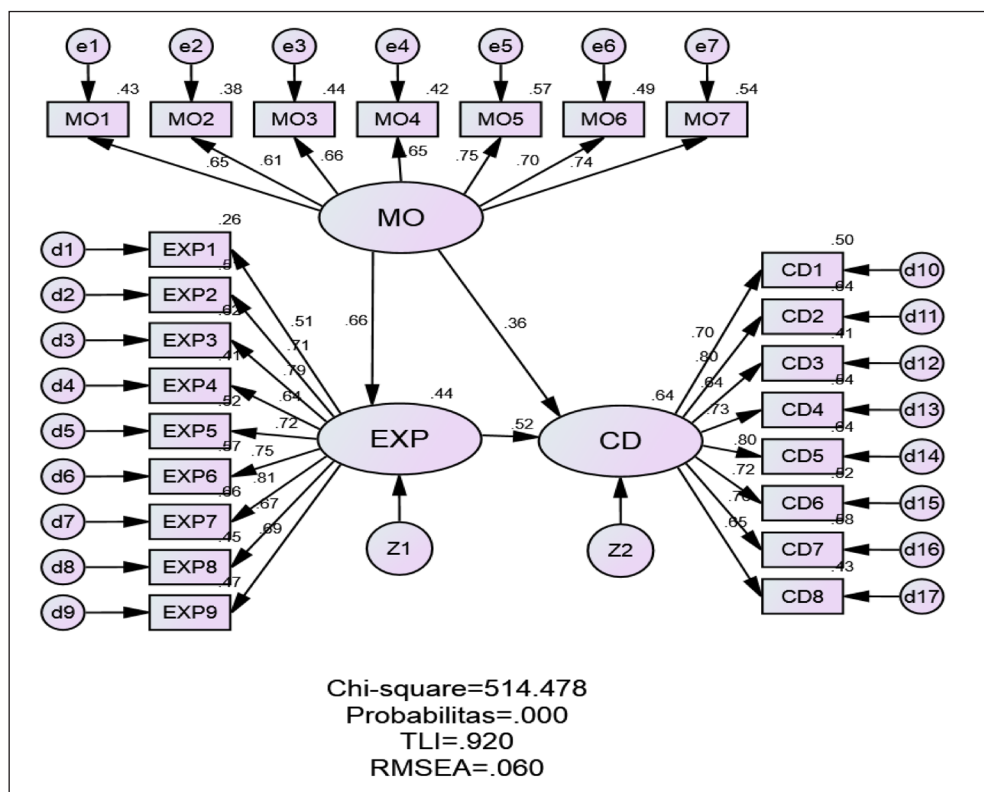

In order to test the statistical hypothesis partially, t-test statistic used, reject hypothesis 0 (H0) if the value of the t-statistic is bigger than 1,96 or if the p-value is smaller than the significance level or α (0,05).

H1 = There is an influence of travel motivation on destination image

H2 = There is an influence of tourism experience on the destination image

H3 = There is an influence of travel motivation on the memorable travel experience

Result and Discussion

The respondent's characteristic data shows that most respondents know the area information through the following media. Internet media 38%, 11% from television, 31% of respondents have visited twice the eco-tourism area, 45% of respondents visited for 3 days, 69% of respondents spend less than 1 million for 1 visit, 62% of respondents are 18 years old up to 25 years old, with 34% students and 25% private employees, Santolo beach is the most favorite beach to visit by tourists. The results of the measurement model for each variable are in Table 1.

Table 1. Factor Loading Result of Travel Motivation

			Factor loading	t _{scale}	R ²	Error Variance	VE	CR
MO.1	<---	X1	0.652	n.a	0.425	0.575	0.466	0.859
MO.2	<---	X1	0.614	9.262	0.377	0.623		
MO.3	<---	X1	0.661	9.854	0.436	0.564		
MO.4	<---	X1	0.651	9.735	0.424	0.576		
MO.5	<---	X1	0.752	10.938	0.565	0.435		
MO.6	<---	X1	0.700	10.340	0.490	0.510		
MO.7	<---	X1	0.737	10.768	0.543	0.457		

Source: Data Processed

Results in Table 1 shows that factor loading from travel motivation variable is above the average value 0,5, which means the value is around 0.8-0.9. The tscore obtained from every variable manifest more than 1.96. That means the manifest variable used is significant to measure travel motivation used. Construct reliability (CR) of travel motivation variable is 0.859. This value show that latent variable formed have relatify high reliability and indicator used on latent variable have a good fit. The result from Variance Extracted (VE) for the latent travel motivation latent variable is 0.466, in marginal potition. MO 5 dimension which is a runaway from routine shows the highest number of factor Loading. Daily routine activities that make people tired due to daily trips to a jammed office, air pollution, noise, and pressure at work to reach the target, will affect individual's physical and mental health, and in the end, will reduce productivity. This condition will produce another need, that can fill through traveling, this resulting in travel motivation within individuals. The validity of this dimension

in line with the previous research done by McCabe (2014), Pratminingsih et al. (2014). Furthermore, it becomes the duty of the tourist area managers and tourism businessman in the area to provide tourism products that can meet the needs which arise from the travel motivatio of the individual.

The results in Table 2 shows that the factor loading of the memorable travel experience variable is proper, which is above the critical value of 0.5, and within ranges from 0.5 to 0.8. The tscore value obtained for each dimension is more than 1.96, this means that the dimensions used are significant in measuring the variable of memorable travel experience. Value of Construct Reliability (CR) of memorable travel experience variable is above 0.7 which is 0.955. This value shows the latent variables formed have a relatively high degree of reliability, and the indicators used in the latent variables have good validity. Results of Variance Extracted (VE) calculations for latent memorable tourism experience variable is 0.50.

Table 2. Factor Loading Results of Memorable Travel Experience

			Factor loading	t _{score}	R ²	Error Variance	VE	CR
EXP.1	<---	X2	0.508	n.a	0.258	0.742	0.50	0.897
EXP.2	<---	X2	0.713	8.439	0.508	0.492		
EXP.3	<---	X2	0.786	8.843	0.618	0.382		
EXP.4	<---	X2	0.640	7.97	0.410	0.590		
EXP.5	<---	X2	0.719	8.472	0.516	0.484		
EXP.6	<---	X2	0.754	8.675	0.569	0.431		
EXP.7	<---	X2	0.810	8.962	0.656	0.344		
EXP.8	<---	X2	0.671	8.179	0.451	0.549		
EXP.9	<---	X2	0.685	8.267	0.469	0.531		

Source: Data Processed

The new dimension used in this study, EXP9 shows the value of factor loading is 0.685 including a valid and reliable dimension for measuring memorable tourism experience variable. The real form of increasing social relationship is a strong, happy sensation that comes when the individual enjoyed the beauty of nature at eco-tourism area in the south coast of West Java together with spouse, family or friends. The consequences from this are increased relationship quality toward better relationship due to traveling together with a couple, family, and friends have appropriately perceived and managed to become a new scale or new dimension (novelty) in this research, to create a memorable travel experience. So this dimension can be used to measure the memorable tourism experience variable on resembling or similar tourist characters in other tourism areas.

Highest factor loading value shown on knowledge dimension, respondent says that having a new knowledge from historical heritage from the area, which is a port built in Dutch colonial times and a few ancient relics site from Padjadjaran kingdoms era. The knowledge

dimension that valid to measure a memorable travel experience is in line with previous research by Kim and Chen (2016), Kim (2014, 2017), Kim et al. (2012).

The result in Table 3 shows that factor loading from the dimension in destination image variable is good, which is above the average loading factor 0.5 ranges between 0.6 to 0.9. The t_{scale} value obtained from every manifest variable is more than 1.96 this means that indicator that used is significant to measure destination image variable used. Construct Reliability (CR) re-visit intention variable is above 0.7, which is 0.900. This value shows that the formed latent variable have the relatively high level of reliability and indicator used in latent variable have good validity. The result of Variance Extracted (VE) for latent variable, re-visit intention is 0.532. The biggest value of factor loading is on the CD2 dimension, which is the natural attraction. Respondents argue that in the region has beautiful scenery, more exotic beach, and cooler beach air, as well as beautiful scenery, can also be obtained during the way to the location of the tourism area. The dimension that has the least factor loading is the CD3 dimension that is the opportunity to do the adventure tour, and the respondent thinks the facility for doing adventure tour is considered less, rarely encountered by adventure tour operator, even the existing operators have bad management. The valid dimension in this research is in line with Chi and Qu (2008), Tosun et al. (2015) research.

Table 3. Factor Loading Result of Destination Image

			Factor loading	t_{scale}	R^2	Error Variance	VE	CR
CD.1	<---	Y	0.705		0.496	0.504	0.532	0.900
CD.2	<---	Y	0.801	13.088	0.642	0.358		
CD.3	<---	Y	0.644	10.586	0.414	0.586		
CD.4	<---	Y	0.734	12.033	0.539	0.461		
CD.5	<---	Y	0.801	13.082	0.641	0.359		
CD.6	<---	Y	0.718	11.774	0.515	0.485		
CD.7	<---	Y	0.761	12.455	0.579	0.421		
CD.8	<---	Y	0.654	10.747	0.427	0.573		

Source: Data Processed

In the level of full model phase, structural equation (Structural Equation Modelling (SEM)) is applied just like the structural model in Figure. 1. The result of the goodness of fit model explained in Table 4.

From χ^2 value indicator compared to df, resulting in a marginal value, though the CMIN/df result is 1,523 smaller than 2, which means that the model can be accepted. RMSEA value (Root Mean Square Error of Approximation) for the model in this research is 0,06. The RMSEA value shows the goodness of fit that can expect when the model estimated within the population. RMSEA value is smaller than 0.08 shows that the model is fit with data (based on how many degrees of freedom within the model). The result of Baseline

Comparison and Parsimony-Adjusted shows Fit and marginal, and all of the results shows that the estimated model is fit with structural model data. This result also means that the model proposed in this research can do for the tourist population in eco-tourism area of west java south coast.

Table 4. The Result of Structural Model Goodness of Fit

<i>Goodness of Fit Index</i>	<i>Cut of Value</i>	<i>Result of data analysis</i>	<i>Model evaluation</i>
Chi-Square (df= 249)	286.8078	514.478	marginal
Probability	0.05	0.003	marginal
CMIN/DF	1.523	2.000	Fit
RMSEA	< 0.08	0.060	Fit
<i>Baseline Comparisons</i>			
<i>Normed Fit Index (NFI)</i>	0.900	0.870	Marginal
Comparative Fit Index (CFI)	0.900	0.928	Fit
IFI	0.900	0.929	Fit
TLI	0.900	0.920	Fit
<i>Parsimony-Adjusted Measures</i>			
PNFI	0.900	0.785	Marginal
PCFI	0.900	0.837	Marginal

Source: Data Processed

The result of hypothesis testing are travel motivation is affecting the destination image (H), and memorable travel experience is affecting destination image (H2). Travel motivation towards memorable travel experience is a generalization form of the whole model based on Table 5.

Table 5. Coefficient Patch and Result of Hypothesis Testing

Hypothesis	Coefficient path	t_{scale}	p	R²	t critical F_{table}	Decision
Travel destination toward destination image (H1)	0.356	4.949	0.000	12.7%	1.96	<i>Supported</i>
Memorable travel experience toward destination image (H2)	0.518	5.939	0.000	26.8%	1.96	<i>Supported</i>
Travel motivation toward memorable travel experience (H3)	0,664	6.863	0.000	44.1%	1.96	<i>Supported</i>

Source: Data Processed

Based on the result of the calculation in Table 5 on hypothesis 1, the traveling motivation has a significant effect to the destination image, the traveling motivation as the driving factor

of internal power can drive the individual tourists to behave or act in meeting the gap of needs that can fulfill from traveling. The first step that an individual is motivated to do is to seek the latest information about the choice of destination that is imaged or perceived by that individual can meet his or her needs. Sources of information can come from many sources and various media, and destination information that best matches the internal drive of the individual concerned has the highest possibility to be chosen. According to the survey results the strongest impulse arises or is caused by the dimensions of freelance and away from the daily routine activities. The implications that arise for the management of tourist areas that create tourism products that can meet these motivations and communicate well means that tourism products are perceived in the same image by consumers as a product needed. It is in line with the research Pratminingsih et al. (2014), Yoon and Uysal (2005).

Hypothesis 2, memorable travel experience is influencing image destination significantly. Memorable travel experience is influencing destination image directly tourism by 26.8%. This result also means unforgettable experiences or tourism experiences, both positive (negative) and negative (bad), will be stored in the memory of the individual subjective evaluation of the overall tourism experience that had done. Experience in the form of individual tourists encounter with tourist areas that involve the senses, emotions and physical, play an essential role as part of personal factors in shaping the image of the destination, or can be said the image will be more easily formed from the experience compared to motivation without encountered with the tourist area. The higher the degree of discrepancy between the experience of tourism program consumption offered and the expectation of the tourists, the stronger negative image will form and it can be applied otherwise it is in line with the research of Beerli and Martín (2004), Kim and Chen (2016), and Kim (2014, 2017). According to survey results, the impressive dimension of tourism experience powerfully shaped by the dimension of knowledge. It can say the influence of tourism experience variable is impressive enough. It is expected to be a substantial concern of tourism business actors and tourism area managers to package experience-based quality program with an emphasis on programs that invite tourist involvement in enhancing knowledge sourced from the natural, cultural and historical potential of the region. It expected that the program could firmly embed in the minds of tourists who manifested in the positive image of eco-tourism area of the southern coast of West Java.

In hypothesis 3 the traveling motivation has a significant effect on the memorable tourism experience. The effect of traveling motivation to memorable tourism experience of 44.1% is the most significant influence in this research model. The most powerful dimensions of traveling motivation are the desire to break out from the daily routine activities to referral area managers and tourism business actors in making strategies and programs for tourism product creation based on the memorable tourism experience. In the memorable tourism experience variable, two dimensions are worthy of consideration in packaging tourism products namely the dimension of knowledge and the improvement of social relationships in the form of togetherness. The integration of these three dimensions in one unified strategy and program of tourism product creation is ultimately expected to form a strong positive image for each tourist. This result is in line with the research by Kim and Chen (2016).

Conclusion

Travel motivation and memorable tourism experience significantly influence the destination image partially. The motivation of the tour has a significant effect on the memorable tourism experience, and it also has the most significant influence compared to other variable relations in this research model. Regarding improving the destination image, a memorable tourism experience has a more critical role than the travel motivation. Because in the memorable tourism experience, there must be an encounter between tourist and eco-tourism areas that involve the senses, physical and emotional, so they are easily attached to the memory of individual tourists compared with travel motivation that only forms the destination's image through information in the media. The most significant indicator of travel motivation is an escape from daily activities at home and at work and also in the sightseeing of the tourism destination.

The implication of those conditions is the product development strategy can direct to the most considerable influence of travel motivation indicator with the aim of improving the destination image which in turn will increase the number of visits. Strategy and work program can divide into two stages which are before and during the visit. The program before visiting in the form of information program through internet media, social media, and word of mouth all matters about eco-tourism area of the south coast of West Java which is integrated and well managed. The programs at the time of visit can vary significantly with the principle of tourism products that can overcome the boredom from the tourists' home environment. Tourism products package should base on the strongest dimensions of the memorable tourism experience concept of knowledge in the form of exploration of the nature, culture and history potentials in the tourist areas that have the competitiveness to be offered to the tourists. The eco-tourism area of the south coast of West Java is vast and consists of three districts, so the policy for the region management is to establish a management institution that aims to overcome the management complexity of the eco-tourism area of the southern coast of West Java and improve the coordination effectiveness among the stakeholders.

References

- Beerli, A., & Martín, J. D. (2004). Tourists' Characteristics and The Perceived Image of Tourist Destinations: a Quantitative Analysis—a Case Study of Lanzarote, Spain. *Tourism Management*. Vol. 25(5): 623-636. doi: <https://doi.org/10.1016/j.tourman.2003.06.004>.
- Chandralal, L., Rindfleish, J., & Valenzuela, F. (2015). An Application of Travel Blog Narratives to Explore Memorable Tourism Experiences. *Asia Pacific Journal of Tourism Research*. Vol. 20(6): 680-693. doi: <https://doi.org/10.1080/10941665.2014.925944>.
- Chandralal, L., & Valenzuela, F.-R. (2013). Exploring Memorable Tourism Experiences: Antecedents and Behavioural Outcomes. *Journal of Economics, Business and Management*. Vol. 1(2): 177-181. doi: <https://doi.org/10.7763/JOEBM.2013.V1.38>.
- Chang, L.-L., F. Backman, K., & Chih Huang, Y. (2014). Creative Tourism: a Preliminary Examination of Creative Tourists' Motivation, Experience, Perceived Value, and Revisit

- Intention. *International Journal of Culture, Tourism and Hospitality Research*. Vol. 8(4): 401-419. doi: <https://doi.org/10.1108/IJCTHR-04-2014-0032>.
- Chi, C. G.-Q., & Qu, H. (2008). Examining The Structural Relationships of Destination Image, Tourist Satisfaction and Destination Loyalty: An Integrated Approach. *Tourism management*. Vol. 29(4): 624-636. doi: <https://doi.org/10.1016/j.tourman.2007.06.007>.
- Cooper, D. R., & Schindler, P. S. (2014). *Business Research Method* (12 ed.). New York: Mc Graw-Hill Education.
- Ferdinand, A. (2014). *Structural Equation Modelling in Research Management* (5 ed.). Semarang: BP UNDIP Press.
- Khan, M. J., Chelliah, S., & Ahmed, S. (2017). Factors Influencing Destination Image and Visit Intention Among Young Women Travellers: Role of Travel Motivation, Perceived Risks, and Travel Constraints. *Asia Pacific Journal of Tourism Research*. Vol. 22(11): 1139-1155. doi: <https://doi.org/10.1080/10941665.2017.1374985>.
- Kim, H., & Chen, J. S. (2016). Destination Image Formation Process: A Holistic Model. *Journal of Vacation Marketing*. Vol. 22(2): 154-166. doi: <https://doi.org/10.1177/1356766715591870>.
- Kim, J.-H. (2014). The Antecedents of Memorable Tourism Experiences: The Development of a Scale to Measure The Destination Attributes Associated with Memorable Experiences. *Tourism Management*. Vol. 44: 34-45. doi: <https://doi.org/10.1016/j.tourman.2014.02.007>.
- Kim, J.-H. (2017). The Impact of Memorable Tourism Experiences on Loyalty Behaviors: The Mediating Effects of Destination Image and Satisfaction. *Journal of Travel Research*. Vol. 56(1): 30-40. doi: <https://doi.org/10.1177/0047287517721369>.
- Kim, J.-H., Ritchie, J., & Tung, V. W. S. (2010). The Effect of Memorable Experience on Behavioral Intentions in Tourism: A Structural Equation Modeling Approach. *Tourism Analysis*. Vol. 15(6): 637-648.
- Kim, J.-H., Ritchie, J. B., & McCormick, B. (2012). Development of a Scale to Measure Memorable Tourism Experiences. *Journal of Travel Research*. Vol. 51(1): 12-25. doi: <https://doi.org/10.1177/0047287510385467>.
- Lertputtarak, S. (2012). The Relationship Between Destination Image, Food Image, and Revisiting Pattaya. *Thailand International Journal of Business and Management*. Vol. 7(5): 111-121. available at SSRN: <https://ssrn.com/abstract=2392148>.
- McCabe, S. (2014). *The Routledge Handbook of Tourism Marketing*. London: Routledge.
- Ministry-Of-Tourism. (2016). *Performance Report of Ministry of Tourism*. Retrieved from
- Oh, H., Fiore, A. M., & Jeoung, M. (2007). Measuring Experience Economy Concepts: Tourism Applications. *Journal of Travel Research*. Vol. 46(2): 119-132. doi: <https://doi.org/10.1177/0047287507304039>.
- Pratminingsih, S. A., Rudatin, C. L., & Rimenta, T. (2014). Roles of Motivation and Destination Image in Predicting Tourist Revisit Intention: A Case of Bandung-Indonesia. *International Journal of Innovation, Management and Technology*. Vol. 5(1): 19-24. doi: <https://doi.org/10.7763/IJIMT.2014.V5.479>.

- Prayag, G., & Ryan, C. (2011). The Relationship Between The 'Push'and 'Pull' Factors of a Tourist Destination: The Role of Nationality– an Analytical Qualitative Research Approach. *Current Issues in Tourism*. Vol. 14(2): 121-143. doi: <https://doi.org/10.1080/13683501003623802>.
- Rageh, A., & Melewar, T. (2013). Using Netnography Research Method to Reveal The Underlying Dimensions of The Customer/Tourist Experience. *Qualitative Market Research: An International Journal*. Vol. 16(2): 126-149. doi: <https://doi.org/10.1108/13522751311317558>.
- Ritchie, J. R. B., Wing Sun Tung, V., & JB Ritchie, R. (2011). Tourism Experience Management Research: Emergence, Evolution and Future Directions. *International Journal of Contemporary Hospitality Management*. Vol. 23(4): 419-438. doi: <https://doi.org/10.1108/09596111111129968>.
- Sekaran, U., & Bougie, R. (2016). *Research Methods for Business: A Skill Building Approach*. New York: John Wiley & Sons.
- Shi, L., Cole, S., & Chancellor, H. C. (2012). Understanding Leisure Travel Motivations of Travelers with Acquired Mobility Impairments. *Tourism Management*. Vol. 33(1): 228-231. doi: <https://doi.org/10.1016/j.tourman.2011.02.007>.
- Sthapit, E., & Coudounaris, D. N. (2018). Memorable Tourism Experiences: Antecedents and Outcomes. *Scandinavian Journal of Hospitality and Tourism*. Vol. 18(1): 72-94. doi: <https://doi.org/10.1080/15022250.2017.1287003>.
- Tosun, C., Dedeoğlu, B. B., & Fyall, A. (2015). Destination Service Quality, Affective Image and Revisit Intention: The Moderating Role of Past Experience. *Journal of Destination Marketing and Management*. Vol. 4(4): 222-234. doi: <https://doi.org/10.1016/j.jdmm.2015.08.002>.
- Tsai, C. T. S. (2016). Memorable Tourist Experiences and Place Attachment When Consuming Local Food. *International Journal of Tourism Research*. Vol. 18(6): 536-548. doi: <https://doi.org/10.1002/jtr.2070>.
- Yoon, Y., & Uysal, M. (2005). An Examination of The Effects of Motivation and Satisfaction on Destination Loyalty: a Structural Model. *Tourism Management*. Vol. 26(1): 45-56. doi: <https://doi.org/10.1016/j.tourman.2003.08.016>.
- Zhang, H., Wu, Y., & Buhalis, D. (2017). A Model of Perceived Image, Memorable Tourism Experiences and Revisit Intention. *Journal of Destination Marketing & Management*. Vol. 8: 326-336. doi: <https://doi.org/10.1016/j.jdmm.2017.06.004>.
- Zhang, Y., & Peng, Y. (2014). Understanding Travel Motivations of Chinese Tourists Visiting Cairns, Australia. *Journal of Hospitality and Tourism management*. Vol. 21: 44-53. doi: <https://doi.org/10.1016/j.jhtm.2014.07.001>.