

INFRASTRUKTUR

FINITE ELEMENT ANALYSIS OF REASONABLE FOUNDATION FOR SUPPORTING SILO'S TOWER

Analisis Elemen Hingga Beberapa Tipe Fondasi Untuk Mendukung Perencanaan Tower Silo

Sukiman Nurdin

Jurusan Teknik Sipil Universitas Tadulako-Jalan Soekarno Hatta Km. 8 Palu 94118, Email : sukiman@yahoo.com

ABSTRACT

The limitation of soil data due to poor soil investigation process is a common problem in civil engineering project. The finite element method was used to analyse the compatibility of foundation to support silos in Liverpool Docks. Both shallow foundation and pile foundation were considered. The results of the analyses are presented by comparing analytical and numerical solution. Parametric study was considered for each case. There are different results for two types of shallow foundation that had been considered. Strip foundation seemed more reliable than pad foundation, while Pile foundation considered to be first choice due to the satisfactory condition for all factors.

Key Words: finite element, silo, shallow and pile foundation.

ABSTRAK

Keterbatasan data tanah karena tidak dilakukannya investigasi tanah secara menyeluruh sebelum proses desain dan konstruksi adalah problem yang umum yang terjadi pada proyek-proyek teknik sipil. Metode elemen hingga adalah dipakai untuk menganalisa jenis pondasi yang dapat mendukung dari silos di Pelabuhan liverpol. Pondasi dangkal maupun pondasi tiang keduanya dipertimbangkan untuk digunakan. Analisa tersebut membandingkan metode numerik maupun analitik. Hasil dari analisa tersebut memperlihatkan hasil yang berbeda dari dua tipe pondasi dangkal. Pondasi strip memberikan nilai yang lebih optimal daripada fondasi pad. Sementara pondasi tiang menjadi pilihan pertama karena kelayakan dari semua faktor yang ditinjau.

Kata Kunci : elemen hingga, silo, pondasi tiang dan dangkal

INTRODUCTION

a. Background

Ten tower silos are used to store combined weight of approximately 3000 tonnes of load. Tower silos were erected at quayside of Alexandra docks in Liverpool.

Over the years silo builders have improved the design and construction of the above-ground portion of silos, in contrast, very little has been done to improve the foundation. Towers have generally been erected on foundations constructed by Fugro Limited. Who have the necessary technology for adequate design and constructed. The practice was reasonably successful when silos were developed. As bigger silos were erected, however, and the applied foundation pressures approached the bearing capacity of the soils, many structures settled considerably, some tilted, and some overturned completely. This digest outlines the problem and indicates the need for a soil investigation to determine the allowable bearing capacity and compressibility of the soil and thus enable proper foundation design.

b. The Problem

Many tower silos constructed on clay soils have ring-shaped concrete foundations. To reduce costs, concrete floors are seldom provided. When the silos are developed for any purposes, part of the load is transmitted through the cylindrical walls to the footings and the remainder is carried directly by the soil inside the ring foundation. The underlying clays compress vertically under the weight of the loaded structure in such a way that the applied loads are distributed uniformly to the soil over the whole area enclosed by the circular foundation. This uniform pressure is distributed to the foundation soil in the form of a pressure bulb; its size and shape, determined by elastic theory, are related directly to the diameter of the loaded area as shown in Figure 1. Here, two footings of different size carry the same uniform load, but the pressure bulb under the larger foundation is much larger and deeper. In each case the maximum vertical pressure occurs immediately below the footing and diminishes to 10 per cent of this value at a depth equal to twice the diameter of the foundation. If the applied stresses within the

bulb do not exceed the shear strength of the soil the structure will be stable.

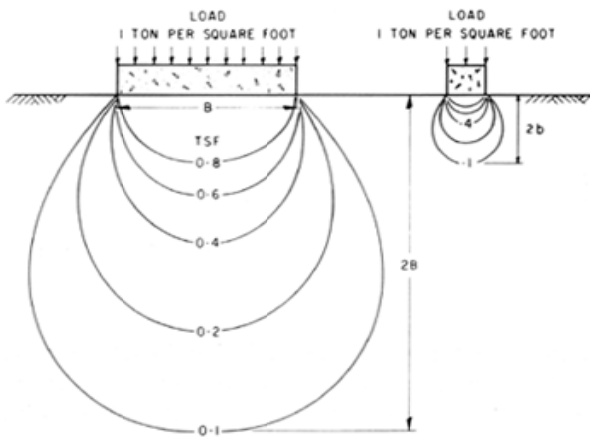

Figure 1. Pressure bulbs under large and small round foundations.

Non-uniform placement of silos during loading has caused many problems. When the load from the weight of the silos and the live load is off centre the pressure bulb will be distorted, as shown in Figure 2(a). Strong winds acting on a tall silo can produce the same effect. The local overstressing of the foundation soil may cause tilting, and unless the problem is remedied it may increase with time until the silo overturns.

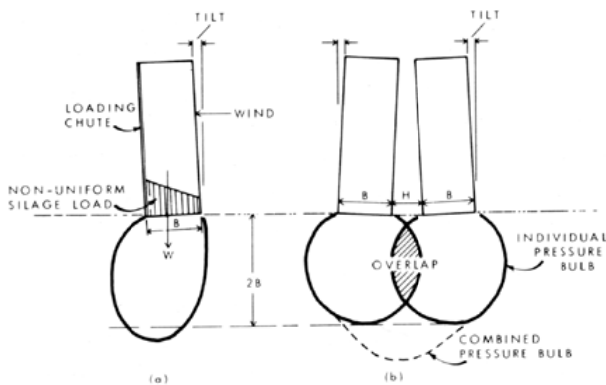

Figure 2. Non-uniform and overlapping pressure bulbs.

Pressure bulbs will overlap, as shown in Figure 2(b), if two or more silos are constructed too close to each other. Because pressures are additive, the resulting pressure bulb will be much larger and will extend to greater depths. The soil in the overlap zone will be subjected to higher stresses and the foundations over this region will settle more, causing the silos to tilt towards each other.

Most foundation failures in clay soils occur when a silo is quickly loaded for the first time. As filling proceeds, the loads are applied to the soil skeleton and to the pore water contained within the voids of the clay. Pressures generated in the pore

water tend to reduce the friction between soil particles and hence decrease the shear strength of the soil. If, at the end of loading, the available shear strength is greater than the applied shear stresses, the structure will be stable. With time the excess pore water pressures will dissipate, the soils will consolidate and gain strength, and the structure will be stable for subsequent loadings.

In silos without floors, silage juices normally seep into the underlying soil. Pore pressures are increased even more, causing a further decrease in the shear strength of the soil. The footings may also become undermined when the liquid flow through the soil under hydraulic pressure. Either or both of these actions can trigger a bearing capacity failure.

c. Site Investigations

Reliable and effective site investigation is widely appreciated in civil engineering and building project, the ground condition is usually given the largest risk element of financial and technical aspect. Almost exclusively, the scope of geotechnical investigation is governed by what is needed to characteristic the subsurface condition appropriately by how much the client and project manager are willing to spend (M.B. Jaksa et al,2005)

Bearing capacity and vertical settlement are directly related to the engineering properties of the soil at a site, so that a soil investigation is required to provide information on soil profile, location of the groundwater table, index properties, shear strength and compressibility.

The site investigation was carried out along Alexandra docks by Fugro Limited. However, the site investigation lacked data to ensure a design of proper foundation to support the silos. Some boreholes were drilled around the site.

d. Technical Aspects of Silo Foundation

Every owner should insist on an adequate foundation for his silo as proposed by Canadian Building Digest (CBD 80, CBD 81). The following points should be considered to ensure a stable structure:

1. Reinforced Footings

A ring foundation is subject to bending stresses from vertical wall loads, soil pressures, and the circumferential loads that exist in the walls at the base of the silo. As concrete has a low tensile strength, the foundation should be reinforced with steel to resist such bending moments and tensile stresses. If the foundation should crack because of insufficient reinforcement, the monolithic behaviour of the ring foundation will be destroyed and its

ability to support the superstructure adequately will be reduced.

2. Concrete Foundation

It is most important to use good quality concrete in a well prepared excavation in which the sides are neatly trimmed and the floor cleaned of all disturbed soil. In granular soils or soils containing boulders, formwork may be necessary. The concrete must be placed with the same care as would be followed in constructing the silo walls. To employ no quality control on either concrete or workmanship is unacceptable!

3. Centring Silo on Footings

Load-bearing walls should be centred on footings whenever possible in order to apply uniform loads to the foundation soil and thus permit full use of its allowable bearing capacity.

Large foundations are required in soft, weak soils to maintain applied pressures within the allowable bearing capacity. Large-diameter ring foundations projecting beyond the silo walls are often used to provide maximum stability against overturning. The interior floor is usually omitted for reasons of economy. The inner diameter of this foundation is normally slightly less than the inner diameter of the silo wall. Because the heavy wall loads applied to the inner edge tend to deform the ring foundation it could easily break into individual sections unless it is properly reinforced. In this case the footing pressures would not be uniform and local overstressing of the underlying soil could occur. With adequate reinforcing, however, and by extending the footing further inside the silo, the contact pressures would be redistributed more uniformly and any tendency of the foundation to deform would be reduced. The additional weight of the silage on the extended footing would be minimal because most of the silage load is transferred to the silo walls through friction.

4. Silo Groups

To avoid any interaction between silos constructed on compressible clays loaded to the allowable bearing capacity it is recommended that the minimum horizontal clearance between them should be not less than the diameter of the ring foundations. If a smaller spacing is desired, the silos should be constructed on piles or on a common mat foundation adequately reinforced to resist the applied bending moments.

5. Silo Load

Large quantities of silo load form when the contents of the silos are stored wet, i.e., when their moisture content is too great. In tower silos

constructed without floors, the liquid can flow under high hydrostatic pressure into the foundation soil and undermine the foundations. They can increase the pore water pressures in saturated clay soils, reducing the shear strength. In addition, chemical reaction with the soil may further decrease soil strength.

An impermeable floor should be installed to prevent any liquids from penetrating the subsoil, and drains should be provided to carry them away and reduce the hydrostatic pressures in the silo. It is important that the drains continue to function for the life of the structure.

e. Bearing Capacity

The ultimate bearing capacity of soils depends on the shear strength (c_u) of the soil, and the depth and shape of foundation.

When a silo overturns the foundation soil rotates along a circular arc (Figure 3). The direction of the applied shear stress along the slip circle changes from 0 to 90 deg from the vertical. In rare cases the shear strength of the soil is isotropic (constant in all directions), but generally it is anisotropic (varies with the direction of applied shear stress). Investigations of marine clays have shown orientation dependent reduction in shear strength of as much as 35 per cent when compared with the strength measured in the vertical direction. It is imperative, therefore, that an adequate factor of safety should be included to allow for strength anisotropy, non-uniform pressures applied to the soil due to eccentric loads and overturning moments from high winds, and to prevent excessive vertical settlements. This factor of safety is applied to the shear strength of the soil. (after *M. Bozozuk*, 1976)

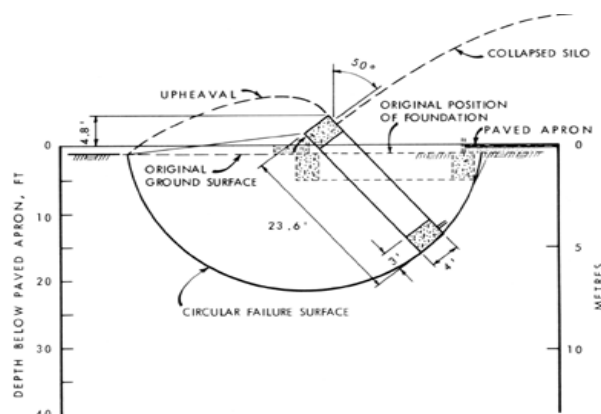

Figure 3. Attitude of a silo foundation after failure.

ANALYTICAL DESIGN

a. Pad Foundation

Table 1. Bearing Capacity of Pad Foundation

Layer	Depth (m)	c _u (kPa)	σ _v (kPa)	q _{ult} (kPa)
1	0.6	60	0.00	386.43
1	2.2	60	46.20	432.63
2	4.65	30	72.87	266.10
3	7.07	35	94.90	320.30
4	11.25	25	137.30	297.90

Settlement

The flexible Settlement Strip Foundation Settlement are:

Table 2. Settlement of Pad Foundation

Depth (m)	ρ _i (mm)	ρ _{c(centre)} (mm)	ρ _{c(corner)} (mm)	ρ _{c(side)} (mm)	ρ _{diff} (mm)	ρ _(total) (mm)
18	23	123.8	52.8	74.3	71	146

Parametric Studies

Table 3. Bearing Capacity with different strength properties of the soil

c _u (kPa)	q _{ult} (kPa)	FoS	Increase in FoS
40	257.62	1.31	-51%
50	322.02	1.64	-20%
60	386.43	1.97	0.0%
70	450.83	2.30	+17.0%
80	515.23	2.63	+34%

b. Strip Foundation

Table 4. Bearing Capacity of Strip Foundation

Layer	Depth (m)	c _u (kPa)	σ _v (kPa)	q _{ult} (kPa)
1	0.6	60	0.00	386.43
2	2.2	60	46.20	432.63
3	4.65	30	72.87	266.10
4	7.07	35	94.90	320.30
5	11.25	25	137.30	297.90

Settlement

Table 5. Settlement of Strip Foundation

Depth (m)	ρ _i (mm)	ρ _{c(centre)} (mm)	ρ _{c(corner)} (mm)	ρ _{c(side)} (mm)	ρ _{diff} (mm)	ρ _(total) (mm)
18m	18.8	118	33	59	85	137

Parametric Studies

Table 6. Bearing Capacity with different strength properties of the soil

No	c _u (kPa)	q _{ult} (kPa)	FoS	Increase in Bearing Capacity
1	40	223.43	2.87	-50%
2	50	279.30	3.59	-20%
3	60	335.14	4.31	0.0%
4	70	391.00	5.03	+17.0%
5	80	446.85	5.76	+34%

b. Pile Foundation

Bearing Capacity

Table 7. Bearing Capacity of Single Pile

Depth (m)	Q _b (kN)	Q _s (kPa)	Q _{ult} (kPa)	q _n (kPa)	FoS
18	108	1221	282	488	2.73

Checking by Eurocode

R_{cd} > q_n = 678.8kN > 488kN, This is satisfactory

Settlement

Table 8. Settlement of Pile Foundation

Depth (m)	ρ _{icentre} (mm)	ρ _{i(corner)} (mm)	ρ _{i(side)} (mm)	P _{averag} (mm)	P _(total) (mm)
18	48	12	43	35	21

Parametric Studies

Table 9. Bearing Capacity with different strength properties of the soil

c _u (kPa)	Q _b (kPa)	Q _s (kPa)	FoS	Change Bearing Capacity
60	81.09	1129.98	2.28	-19.5%
70	94.61	1175.80	2.60	-4.6%
80	108.15	1221.60	2.72	0.0%
90	121.64	1269.95	2.85	+4.8%
100	135.15	1316.53	2.97	+9.5%

NUMERICAL DESIGN

In this chapter the design of types of foundation in the previous chapter will be reviewed and examined using the finite element approach with the help of a computer programme SAFE in OASYS-GEO 17.9. The input and output parameters are the same as the parameters in the analytical design. A study about variation of parameters and convergence study will be produce.

a. Pad Foundation

Table 9. Results of the finite element modelling compared to the analytical solutions

Parameter	Analytical Result	Numerical Result	Difference (%)
FoS	1.97	1.25	57
Settlement	122	44	199

Parametric Study

Bearing Capacity

Table 10. Failure load for runs with different strength properties of the soil

c_u (kPa)	Failure Load (kN/m ²)	FoS	Change in Bearing Capacity
40	204 < q < 206	1.05	-19.1%
50	224 < q < 226	1.15	-8.6%
60	243 < q < 245	1.25	0.0%
70	261 < q < 263	1.34	+7.5%
80	277 < q < 279	1.42	+13.7%

Settlement

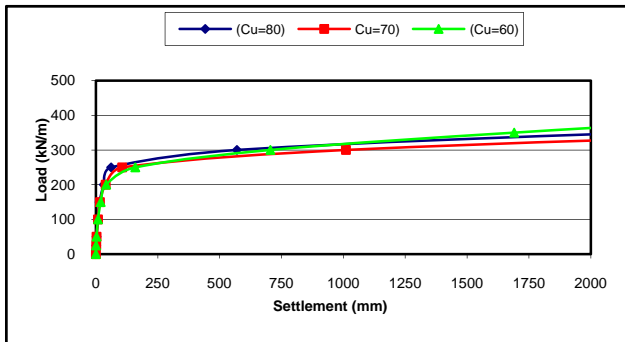

Figure 4. Settlement versus incremental loading for increasing soil strength.

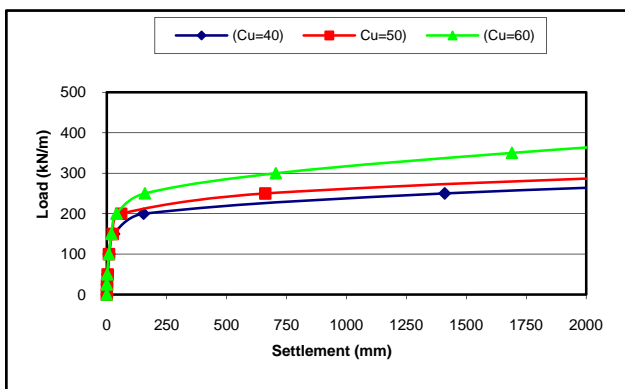

Figure 5. Settlement versus incremental loading for decreasing soil strength.

b. Strip Foundation

Table 11. Results of the finite element modelling compared to the analytical solutions

Parameter	Analytical Result	Numerical Result	Difference (%)
FoS	4.2	2.6	61.5
Settlement	137mm	98mm	40.0

Parametric Study

Bearing Capacity

Table 12. Failure load for runs with different strength properties of the soil

c_u (kPa)	Failure Load (kN/m ²)	FoS	Change In FoS
40	172 < q < 174	2.05	-21.7%
50	186 < q < 188	2.37	-9.5%
60	203 < q < 205	2.62	0.0%
70	222 < q < 224	2.82	+7.8%
80	246 < q < 248	3.03	+15.7

Settlement

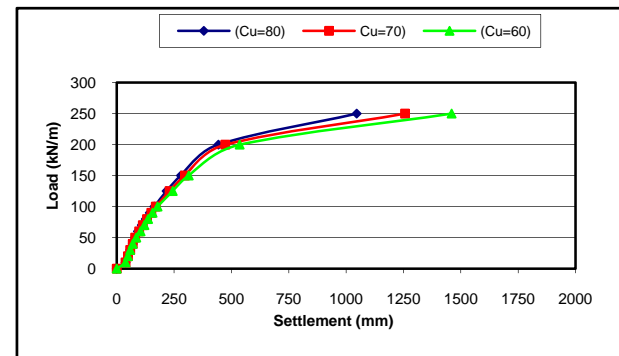

Figure 6. Settlement versus incremental loading for decreasing soil strength.

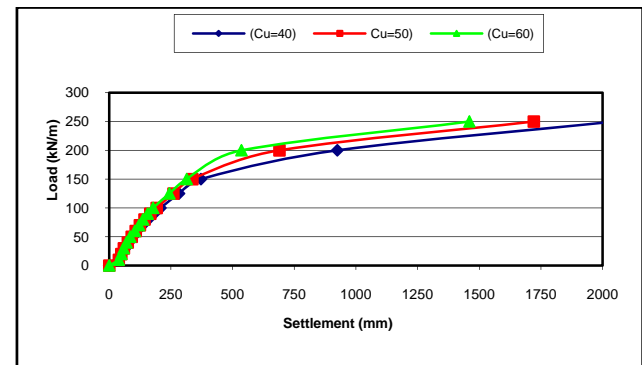

Figure 7. Settlement versus incremental loading for decreasing soil strength.

c. Pile Foundation

Table 13. Results of the finite element modelling compared to the analytical solutions

Parameter	Analytical Result	Numerical Result	Difference (%)
FoS	2.73	1.75	56
Settlement	21mm	19.1mm	10

Parametric Study

Bearing Capacity

Table 14. Failure load for runs with different strength properties of the soil

Cu (kPa)	Failure Load (kN/m ²)	FoS	Change in Bearing Capacity
40	178 < q < 180	1.53	-14.5%
50	191 < q < 193	1.64	-6.6%
60	201 < q < 203	1.75	0.0%
70	208 < q < 210	1.78	+1.8%
80	220 < q < 222	1.89	+8.0%

Settlement

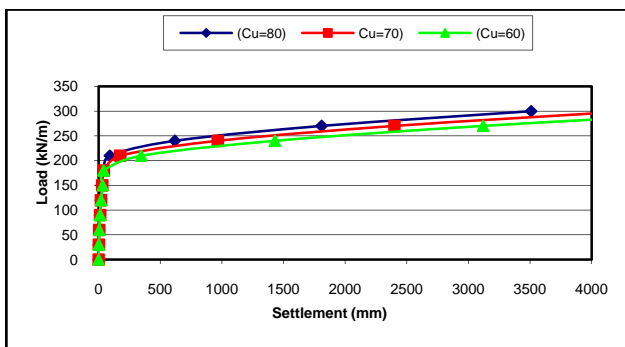

Figure 8. Settlement versus incremental loading for increasing soil strength.

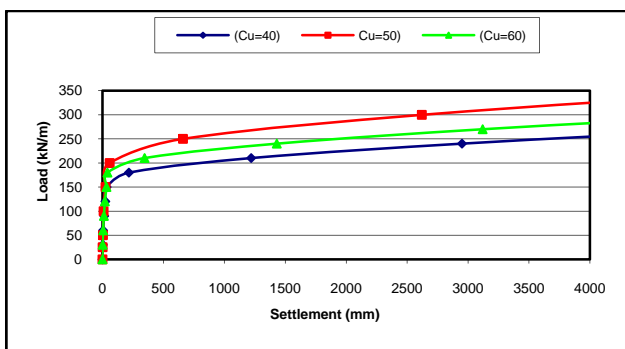

Figure 9. Settlement versus incremental loading for decreasing soil strength.

DISCUSSION

The analytical and numerical design studies were based on the same data input. Nevertheless both of the methods usually produce different results.

a. Pad Foundation

According to the analytical and numerical predictions showed that the pad foundation seems unsatisfactory to support the silos. There are several factors base of those reason. In term of bearing capacity factor produced by analytical method shows that the value of factor safety against bearing failure is 1.92 which is lower than the limit value of failure (2.5). In addition, at the second layer of soils the value of factor of safety decreased to 1.36 which is unsatisfactory. And at the third and fourth layer the value of factor of safety was fluctuated to be 1.63 and 1.52 respectively.

The numerical result analysis appears that the value of factor of safety against bearing failure slightly lower than the analytical method. The factor of safety was produced by numerical analysis of 1.25 that it is lower than the limit value of factor of safety. It can be conclude that numerical method produces lower results than analytical design.

The settlement analysis performed by both methods showed that the settlement seemed a problem in the pad foundation. It can be seen from Table 9 that the analytical and numerical results present the settlement about 122mm and 41mm respectively. Which is the settlement is in critical condition. In addition, the difference settlement provides by analytical method is approximately 71.04 mm, that is can cause the crack on the top of foundation and will impact the stability of the silos. When the parametric study been process to decrease and increase of the strength of the soil, a change of settlement by both study are 17% and 20% respectively, where it seemed not really important effect of the settlements as shown in Table 10 and Figure 4 and 5.

As the low of factor of safety in case of pad foundation design, it seems that some factor could be a problem in the term of the pad foundation been applied. First, plastic deformation might be present due to the inconsistency of the factor of safety in several layers, leading to movement of the foundation greater than settlements; in extreme case failure will occur.

Another problem that could be occur and should be taken under consideration is the non-uniform placement of fill during filling. When the load from the content and the silos is off centre, as

the result, the pressure bulb will be disorder, as shown in figure 2(a). Strong winds acting on tall silo can produce the same effect. The local overstressing of the foundation soil may cause tilting, and unless the problem is remedied it may increase with time until the silo overturns.

If two or more silos are constructed too close to each other, consequently, the pressure bulb will overlap, as shown in figure 2(b). Because of pressure are additive, the resulting pressure bulb will be much larger and will extend to greater depths. In the overlap zone, the soil will be subjected to higher stresses and the foundation in this region will be settling more, causing the silos to tilt toward each other.

The construction cost for the pad foundation will be very expensive, because it is required large amount of concrete and long time construction process. It is also required advance of site investigation to secure of stability of the silos in long-term period. And the space could be a problem for constructing the pad in the site due to the limitation of the area.

b. Strip Foundation

As can be seen from the analytical and numerical predictions, that showed the strip foundation seems feasible to support the silos in term of factor of safety. There are several factors base of those reason. In term of bearing capacity factor produced by analytical method shows that the value of factor safety against bearing failure is 4.2 which is satisfactory. In addition, at the second layer of soils the value of factor of safety decreased to 3.0 which is satisfactory. And at the third and fourth layer the value of factor of safety was consistence decrease in 3.6 and 3.5 respectively. However, the numerical result analysis appears that the value of factor of safety against bearing failure lower than the analytical method. The factor of safety was produced by numerical analysis approximately 2.6 that it is near to the limit value of factor of safety of 2.5. It seems that the numerical method produces lower results than analytical design.

The settlement analysis performed by both methods showed that the settlement is big case that really a problem in term of strip foundation been applied. It can be seen from Table 11 that the analytical and numerical results present the settlement about 137mm and 98mm respectively. Which is the settlement is in critical condition. In other hand, the difference settlement showed by analytical method is very high that it is approximately 85mm, that it is can cause the crack on the top of foundation and will impact the stability

of the structure of the silos. In extreme case can cause the failure of the silos.

As the high of the settlement and the difference settlement predicted in strip foundation design, it can be conclude that the strip foundation unfeasible for the silos. Furthermore, nine silos build in the row requires large of space along the docks, unfortunately, limited space is a problem in the site due to existing structure.

The construction cost for the strip foundation will be very expensive, because it is required large amount of concrete and long time construction process. It is also required advance of site investigation to secure of stability of the silos in long-term period.

c. Pile Foundation

According to the analytical result that pile foundation is feasible for the silos, which the settlement predicted is approximately 21mm that is can be neglected, So that the results obtained prove that the pile foundation is considered to the most feasible choice for support the silos. Furthermore, the numerical predictions showed as same as analytical prediction that the pile foundation seems satisfactory to support the silos. In the other hand, checking by Eurocode that all the conditions had been satisfied for the safety of the structure. That means that the little difference in prediction between numerical and analytical is not really significant that can affect the structure. It could be conclude as satisfactory.

In term of bearing capacity factor produced by analytical method shows that the value of factor safety against bearing failure is 2.73 which is higher than the limit value that have been given (2.5). However, at the pile group analysis, the value of factor of safety is very high approximately 9.6 which it is satisfactory. In other hand, numerical prediction is rather pessimistic where the factor of safety was presented approximately 1.75. The factor that caused the low of factor safety produce by numerical could be the lack of soil information that presented and the conservative assumption that been chosen in order to carry out the design procedure. In addition, the groundwater level was been taken rather conservative, while it has important effect on ultimate bearing capacity of foundation. With the high groundwater levels, the effective stresses in the ground are lower than when the soils immediately below the foundation are dry, and the ultimate bearing capacity is reduced.

The settlement analysis performed by both methods showed that the settlement is not really a problem in the pile foundation. It can be seen from

Table 13 that the analytical and numerical results present the settlement about 21mm and 19.1mm respectively. Which it is can be neglected. The difference about the prediction of the settlement analysis by both methods is approximately 10%.

Many types of pile for support the silos structure are available. Driven and cast in places piles are economical for land structure. But the ground heave and the vibration associated with the installation can cause destabilization of quay wall. Bored and cast in the place are the cheapest types of the pile, which it is possible to be chosen because it will keep the cost of foundation efficiently.

The construction cost for the pile foundation will be cheaper than other types of foundation, because it is not required large amount of concrete and short time construction process.

CONCLUSION

As the result of analytical and numerical design of the foundation for support the silos, there are several point that can be conclude:

The pad foundation proved to be unsuitable from any aspects of foundation design, as can be seen from the results of factor of safety against failure were unsatisfactory predicted both by analytical and numerical methods. Where it could be cause plastic deformation within the soil. Furthermore, it will lead to movement of the foundation greater than settlements; in extreme case failure will occur. Furthermore, the pad foundation will be expensive structure due to required large quantity of concrete and time consuming.

In the terms of factor of safety the strip foundation seemed to be feasible for the silos. Because the high value of factor of safety predicted by analytical methods. However, the settlement is really a critical problem that faced by strip foundation. Both numerical and analytical predicted the critical value of settlement. In addition, the difference settlement showed by analytical method is very high that it can cause the crack on the top of foundation and will impact the silo's structure. As the high of the settlement and the difference settlement predicted in strip foundation design, it can be conclude that the strip foundation is unreliable for the silos. Furthermore, nine silos build in the row requires large of space along the docks, unfortunately, limited space is a problem in the site due to existing structure on the site.

Analytical and numerical results obtained prove that the pile foundation is considered to the most feasible choice for support the silos.

Furthermore, the numerical predictions showed as same as analytical prediction that the pile foundation seems satisfactory to support the silos. In the other hand, checking by Eurocode that all the conditions had been satisfied for the safety of the structure. Bored and cast in the place are the cheapest types of the pile, which it is possible to be chosen because it will keep the cost of foundation efficiently. The construction cost for the pile foundation will be cheaper than other types of foundation, because it is not required large amount of concrete and short time construction process.

REFERENCES

- Angush J. MacDonald, 1975, Wind loading on buildings, published by Applied Science Publisher LTD.
- British Standard: 8004, 1986. Code of practice for foundation. Annual book of British Standard, 1986.
- Burland, J.B, and Wroth, C.P., 1974, Settlement of building and associated damage. Review paper, session V.611-54. Settlement of structures. Pentech press. London
- Eurocode 7: Geotechnical Design Part 1: General Rules (ENV 1997-1)
- H. Unwin & R.A Jessep, Long term pile testing in London clay: a case study. In: Proceedings of the Institute of civil engineering, Geotechnical engineering 157, Issue GE2 (2004), pp. 57-63
- G.E. Barnes, 2000, Soil Mechanics: principle and practice, second edition, published by Palgrave Ltd, 2000.
- M.B Jaksa et all, Towards reliable and effective site investigation, Geotechnique 55, No. 2 (2005), pp. 109-121.
- M.J. Tomlinson, 1995, Foundation design and construction, sixth edition, Published by Longman Scientific & Technical.
- M. Bozozuk, 1976, Tower Silo Foundations, Published by Canadian Building Digest
- OASYS-GEO 17.9 Help Manual, 2002-2005.
- Stewart B, 2004, Lectures Notes in Foundation Engineering, University of Glasgow.
- Van Impe & Haegeman, 1998, Deep Foundation on Bored and Auger Piles. "Large Diameter Bored Piles In Multi-Layered Soils of Bangkok"., Balkena, Rotterdam.