



Commitment of Educators in Islamic Boarding Schools: Study at Islamic Boarding Schools in Cilacap Regency

Fathul Aminudin Aziz
State Institute on Islamic Studies Purwokerto
aminazizcenter@gmail.com

Abstract

Islamic boarding school institution is one of the oldest institutions in Indonesia, but its development is slower when it's compared to other institutions. Researcher felt the need to analyze about the influence of organizational development, leadership and communication toward employee motivation, commitment and the implications for boarding school teachers in Cilacap. To test the model and hypotheses, researcher used analysis of Structural Equation Model (SEM). Further more, to estimate the model, the author used the program Analysis of Moment Structures (AMOS). Based on the research of respondents from Islamic boarding school teachers in Cilacap regency, it could be concluded that (1) organizational development, leadership and organizational communication give positive and significant impact on work motivation, either partially or simultaneously, (2) organizational development, leadership, organizational communication and work motivation give positive and significant impact on the commitment of Islamic boarding school teachers, either partially or simultaneously. Results of this study recommend that the commitment of Islamic boarding school teachers can be improved by motivating teachers in internal dimensions, especially those associated with the indicator in the form of an appreciation of science/diploma.

Keywords: *organizational development, leadership, communication, work motivation, commitment*

A. Introduction

Change is a must, not the least in the world of education. Islamic boarding school as an institution that is identical to the meaning of Indonesia's originality (indigenous), religious and legalistic formally recognized as part of the national education system, directly engaged in developing themselves. Many Islamic boarding schools are no longer oriented to curriculum based on religion (Religion-based curriculum), but also touched the question of curriculum nowadays society (society-based curriculum).

Islamic boarding school education is mainly important to the development of Human Resources in order to have a better life and a human humanizing attitude (humanist). But on the other side, Islamic boarding school teachers have their own problems and they must be continually motivated to be more professional. Along with the models, adopting modern education should be done immediately in order to become "Centre of Muslim Revitalizations" in Indonesia.

Many approaches that must be addressed for the boarding school from managerial, organization, human resources, communication, science and religious knowledge. Empirical rational approach should be done, in an effort to get closer to the traditional Islamic boarding school community, together with rational and empirical approach to be something that should be done immediately. In the end, these efforts will finally enhance the appreciation of the Islamic boarding school community members, especially to the teachers at the Islamic boarding school on scholarship with the more complex domain. It means that it's not only the dogmatic theology, but a religion that supported the narrative which is born of the rational and empirical approach, it's results from the study of science and skills.

Islamic boarding school community effort with the tradition of rational and empirical approach can be done by performing the human resources diversification, managerial, scientific, and educational research territory on the education institution in Islamic boarding school. More explicitly, the existence of education institution which reviews general disciplines (non-religious) as domain final study in Islamic boarding school could be a real strategic option in order to increase the motivation of the teachers that finally will be able to increase the commitment of Islamic boarding school teachers who is still considered having lack motivation.

B. Summary Problems

Based on the above description, it can be summarized as follows:

1. Is there any influence of organizational development to the teachers' motivation of Islamic boarding school?
2. Is there any leadership influence to the teachers' motivation of Islamic boarding school?
3. Is there any influence of communication to the teachers' motivation of Islamic boarding school?
4. Is there any influence of organizational development, leadership and simultaneous communication to the teachers' work motivation of Islamic boarding school?
5. Is there any influence of organizational development to the teachers' commitment of Islamic boarding school?
6. Is there any leadership influence to the teachers' commitment of Islamic boarding school?

7. Is there any influence of the communication to the teachers' commitment of Islamic boarding school?
8. Is there any influence of work motivation to the teachers' commitment of Islamic boarding school?
9. Is there any influence of organizational development, leadership, communication and work motivation simultaneously to the teachers' commitment of Islamic boarding school?

C. Research Purposes

Based on the problem's formulation, the purposes of this study, as follow:

1. To analyze and examine the influence of organizational development to the teachers' motivation of Islamic boarding school in Cilacap Regency, Central Java Province.
2. To analyze and determine the effect of leadership to the teachers' motivation of Islamic boarding school in Cilacap Regency, Central Java Province.
3. To analyze and determine the effect of communication to the teachers' motivation of Islamic boarding school in Cilacap Regency, Central Java Province.
4. To analyze and examine the influence of organizational development, leadership and simultaneous communication to the teachers' motivation in Cilacap Islamic boarding school, Central Java Province.
5. To analyze and examine the influence of organizational development to the teachers' commitment of Islamic boarding school in Cilacap Regency, Central Java Province.
6. To analyze and determine the effect of leadership to the teachers' commitment in Cilacap Islamic boarding school, Central Java Province.
7. To analyze and determine the effect of communication to the teachers' commitment of Islamic boarding school in Cilacap Regency, Central Java Province.
8. To analyze and determine the effect of motivation to the teachers' commitment of Islamic boarding school in Cilacap Regency, Central Java Province.
9. To analyze and examine the influence of organizational development, leadership, communication and work motivation simultaneously to the teachers' commitment of Islamic boarding school in Cilacap Regency, Central Java Province.

D. Methodology

Organization Development (OD) is a scientific instrument to enhance organizational effectiveness and health because it contains a number of elements of OD, which is planned, covering the entire organization, long-term impact, involving top management and the use of various forms of intervention based on behavioral approaches (Siagian, Sondra P., 2004: 3-14).

According to Spillane, James P. (2006:10), the leader is a change agent with activity to affect people over the influence these people to him. Similarly, Stuart, Robbert D. and

Barbara B. Morgan (2002:352), said that the leaders are expected to have the ability to influence, giving instructions and also be able to determine the individual to achieve organizational goals.

Daft, Richard L. (2008:363) gave interpretation to the motivation as internal forces or an external person who arouse enthusiasm and resistance to do a series of specific actions.

Hamalik, Oemar (2007:158) argued that the motivation as energy change in a private person who is characterized by the emergence of feelings and reactions to achieve the goal. While Barelson and Steiner suggested that the motivation is an inside person condition which encourages, evokes, or mobilizing and directing or distributing behavior toward the goal. This includes the entire category, motivational impulses, desires, needs and similar power (Siagian, Sondra. P., 2003:95).

Mathis and Jackson, Angelo (2001:99) argued that organizational commitment is the level of trust and acceptance workforce to organizational goals and have a desire to remain in the organization. Kreitner and Kinicki, Angelo (2003:274) argued that organizational commitment reflects on how an individual identifies himself with the organization and tied to goals.

Dimensions of organizational commitment by Meyer and Allen, as written by Luthans, Sweeney and McFarlin (2002:237) has three main components, namely:

affective commitment, including the emotional connection with the organization and the involvement of employees in the organization; *continuance commitment*, including the things that underlie employee loyalty to the organization; *normative commitment*, the employees feeling of obligation that he has to give to the organization.

While Jaros in Laka-Mathebula (2004:15) distinguish organizational commitment in three dimensions, namely: (1) *affective*, it's the level of psychological attachment of individuals to be employees within the organization, (2) *continuance*, it's the feeling of individuals because of the high risk that will be taken when leaving the organization, (3) *moral*, it's the level where individuals are psychologically tied to the goal of being an employee in an organization through internalization of the goals, values, and mission.

Figure 1. Framework Research Model

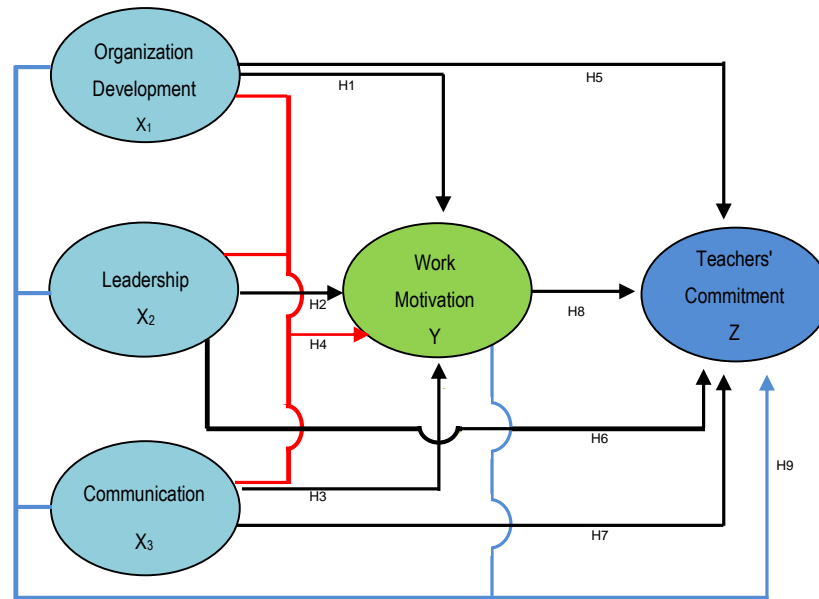

This study was implemented from January 2011 to July 2011 and located throughout the Islamic boarding schools which have formal institutions in the Cilacap regency, Central Java. The research method adopted for the two interests are descriptive and inference. First, *the descriptive research* aimed at obtaining an overview of the characteristics of influence in Arikunto Suharsimi (2010:54) descriptive study conducted by researchers in the hope of results in the form of a description, depiction or description of something. Second, *the inference* would test the truth of a hypothesis through data collection.

Models and hypotheses were tested using analysis of Structural Equation Modeling (SEM). According Waluyo, Minto (2009: 15-25), a complete SEM model basically consists of a Measurement Model and Structural Model. Measurement Model aimed to confirm a dimension or factor based on empirical indicators. While Structural Model is a model through structural relationships among factors that make causality.

Figure 2. Full Structural Equation Model

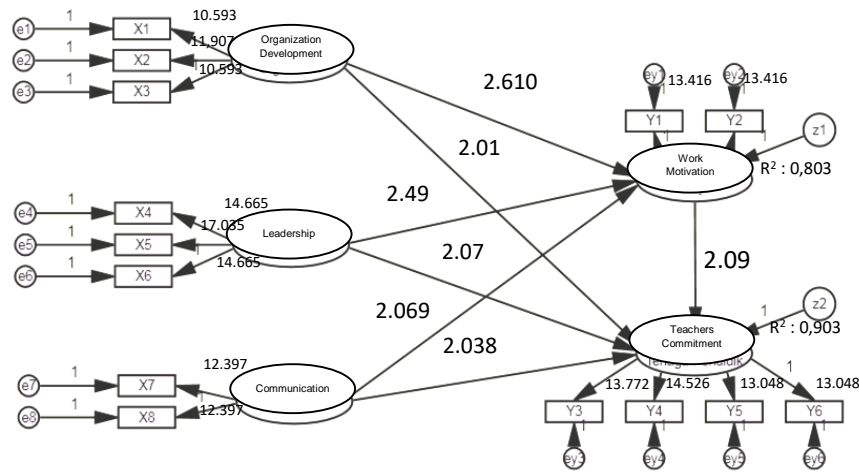

E. Discussion

The result of this research concord with Tiyagi’s opinion in Wibowo (2006) said that organizational development is a planned effort related with the increasing of creativity, skill solving problem, study, and human progress in organization, it’s proven that organizational development give significant influence with work motivation. The value of Critical Ratio (CR) on the influence of organizational development to the work motivation amounted to 2,610. This indicates that CR value > t_{table} (2,610 > 1,960). Thus the hypothesis which indicates organizational development gives significant influence with work motivation is received.

Authentication of organizational development influence with work motivation indicated that the value of highest dimension is human resource amounted to 0,748. Thus the human resources dimension must be maintained, especially indicators that have the highest value that is purpose determination. While managerial and organizational dimensions should be improved in order to maintain the work motivation of teachers in Islamic boarding schools to be always increasing.

Leadership in a broad sense is an activity to influence the behavior of others, or the art of influencing human behavior, both individuals and groups. Leadership should not be limited by the rules, the leadership also does not have to be bound to occur in a certain organization, but leadership can occur anywhere, as long as someone shows his ability to motivate teachers. Leadership gives significant influence on work motivation. Value of Critical Ratio (CR) on leadership influences on work motivation is at 2.496. This indicates that the value of $CR > t_{table}$ (2.496 > 1.960). Thus the hypothesis which indicates leadership significantly influence work motivation is received.

The argumentation of leadership influence on work motivation suggests that the value of the highest dimension is value system which has score 0,833. Thus the value system dimension must be maintained, especially indicators that have the highest value, that is appreciation to the performance of subordinates, while the dimension of behavior and competence should be improved in order to increase motivation of teachers.

Communication gives significant influence on work motivation. Value of Critical Ratio (CR) on communication influences to the work motivation is at 2.069. This indicates that the value of $CR > t_{tabel}$ ($2.069 > 1.960$). Thus the hypothesis which indicates communication significantly influence work motivation is received.

The argumentation of communication influence on work motivation suggests that the value of the highest dimension is the horizontal dimension which has score 0.773. Thus the horizontal dimension must be maintained, especially indicators that have the highest value, that is the available time to communicate, while the vertical dimension must be increased in order to maintain the work motivation of teachers in Islamic boarding schools to be always increasing.

This is in line with the opinion of Robbins (2002) that communication maintain motivation with explanation to the employees on what to do, how well they are doing and what can be done to increase the commitment if it was below standard. Theory of motivation is a concept that is giving an explanation of the person's needs and desires and it's also direct their actions.

Motivation is an activity to give encouragement to someone or yourself to take a desired action. In addition, it also drives people to carry out their activities. If people were motivated to carry out their activities then demonstrated by enthusiastic work activities. This action is because of their sense of belonging is a positive choice to do it. When motivation has been owned by each of teachers then is expected to develop responsibility towards his job, which is also to build willingness to participate in achieving organization goals, it'll finally will create a conducive working environment and can increase the commitment of teachers in teaching.

Organizational development, leadership, and communication simultaneously give significant influence on work motivation. Based on the above results, it appears that the organizational development, leadership, and communication influence the work motivation of the indicated value R square of 0,803. This suggests that organizational development, leadership, and communication simultaneously have a significant contribution to the work motivation.

The argumentation of organizational development, leadership, communication partially or simultaneously influence the work motivation suggests that the most dominant variable is organizational development with the highest value dimension on human resources which has score 0.748. Thus the human resources dimension must be maintained, especially indicators that have the highest value, that is orientation, while the

other dimensions of each variable must be improved either partially or simultaneously in order to maintain the work motivation of teachers in Islamic boarding schools increased.

Organizational development gives significant influences on the teachers' commitment. Value of Critical Ratio (CR) on the influence of organizational development to the teachers' commitment amounted to 2,016. This indicates that the value of $CR > t_{tabel}$ ($2.016 > 1.960$). Thus the hypothesis which indicates organizational development gives significant influence to the teachers' commitment received.

The argumentation of organizational development significantly influence the teachers' commitment suggests that the value of the highest dimension is the human resources which has score 0.748. Thus the human resources dimension must be maintained, especially indicators that have the highest value, that is orientation, while managerial and organizational dimensions should be increased so that the commitment of Islamic boarding school teachers improved.

Leadership gives significant influence on the commitment of teachers. CR values on leadership influence to the teachers' commitments amounted to 2,072. This indicates that the value of $CR > t_{tabel}$ ($2.072 > 1.960$). Thus the hypothesis which indicates leadership influences the teachers' commitment received.

Discussion of leadership influence the teachers' commitment suggests that the value of the highest dimension is the value system which has score 0.833. Thus the value of the system dimensions must be maintained, especially indicators that have the highest value, that is appreciation to the performance of subordinates, while the dimension of behavior and competence should be continuously improved so that teachers' commitment get higher.

Communication between leaders and subordinates cannot be separated from the paternalistic culture that is leaders rarely or never give authority to his subordinates to act independently, to take initiative and make decisions. This is because the communication made by leaders to subordinates is formal where there's a far organizational structure between leaders and subordinates. The consequences of this behavior that subordinates are not used as a source of information, ideas, and suggestions. In the absence of information, ideas, and suggestions from subordinates, a leader will not know the weaknesses and shortcomings so that the leader can be detrimental because of the presence of information, ideas, and suggestions from the subordinates, the leader can plan to further increase his commitment or his subordinates commitment.

With a good leadership, teachers feel trust, admiration, loyalty and respect for leaders and teachers are motivated to do more than expected. Leaders must be able to make teachers more aware of the importance and value of the work and persuade them not to prioritize self-interest for the sake of a larger organization.

Good leadership will develop the skills and confidence to the teachers about responsibility more and more in an organization that gives authority. With this lack of

leadership will be able to increase the commitments that had been made because teachers will give priority to the common good than personal interests.

Communication gives significant influence to the teachers' commitment. Value of Critical Ratio (CR) on communication influences to the teachers' commitment is equal to 2.038. This indicates that the value of $CR > t_{tabel}$ ($2.038 > 1.960$). Thus the hypothesis which indicates the communication influences the teachers' commitment.

Communication influences to the teachers' commitment indicates that the value of the highest dimension is the horizontal dimension which has score 0.773. Thus the horizontal dimension must be maintained, especially indicators that have the highest value, that is available time to communicate, while the vertical dimension must be increased in order to maintain the work motivation of teachers in Islamic boarding school continues to increase.

Work motivation gives significant influence to the teachers' commitment. Value of Critical Ratio (CR) on the influence of motivation to the teachers' commitment is at 2.097. This indicates that the value of $CR > t_{tabel}$ ($2.097 > 1.960$). Thus the hypothesis which indicates motivation significantly influence to the teachers' commitment received.

Work motivation influence to the teachers' commitment indicated that the highest value is the internal dimensions which has score 0.799. Thus the internal dimensions must be maintained, especially indicators that have the highest value, that is scholarship / diploma appreciation, while the external dimensions and indicators should be improved so that so that teachers' commitment get higher.

Organizational development, leadership, communication and work motivation simultaneously give significant influence to the teachers' commitment.

Based on the above results it appears that organizational development, leadership, communication, and motivation influence the teachers' commitment which is indicated the value of R square of 0.903. This suggests that organizational development, leadership, communication, and work motivation simultaneously have a significant contribution to the teachers' commitment.

Organizational development, leadership, communication and work motivation jointly influence the teachers' commitments shows that the most dominant variable is work motivation on the internal dimensions amounted to 0.799. Thus the internal dimensions must be maintained, especially indicators that have the highest value, that is scholarship / diploma appreciation, while the dimensions and other indicators should continue to be developed so that the teachers' commitment in Islamic boarding school in Cilacap District continues to increase.

Commitment of Islamic boarding school teachers built together with the organizational development, the pattern of democratic leadership, good communication, and maintained motivation. Organizational commitment is a psychological construct that is characteristic of relationship organization members with their organization. Teachers

who are committed to the organization will be able to survive as part of an Islamic boarding school than members who do not have a commitment to the Islamic boarding school.

Figure 3. Full Structural Model

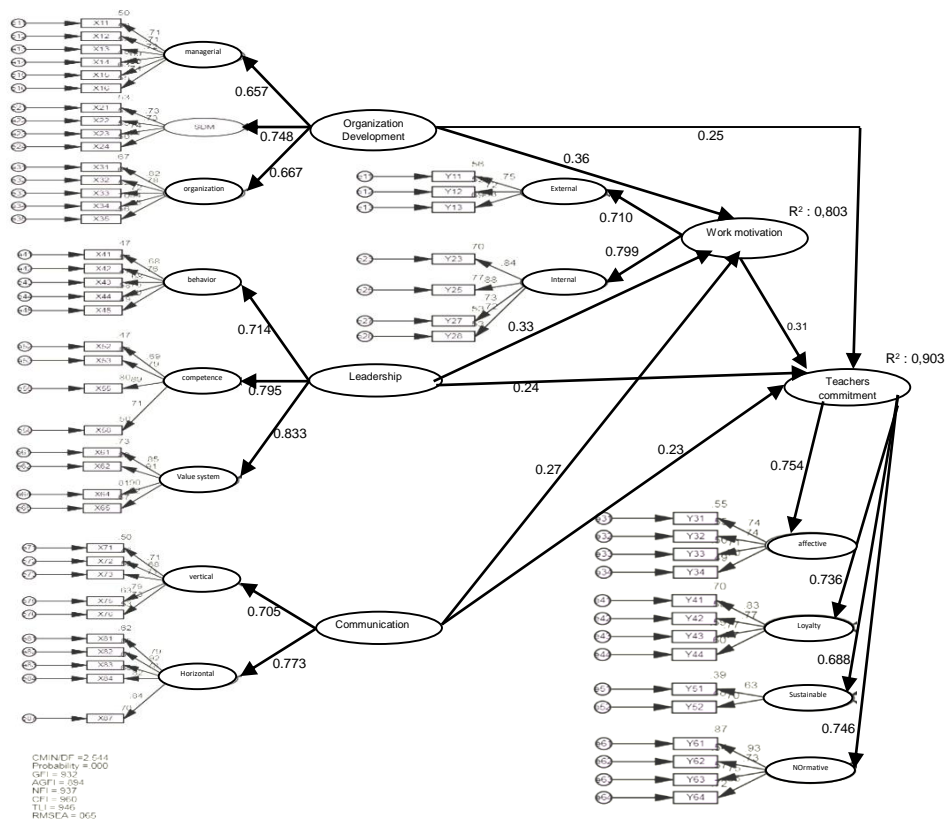

F. Conclusion

Based on the results of the study indicate that organizational development, leadership, and organizational communication affect the teachers' motivation of Islamic boarding school, it's proved by the value of R square of 0,803. This suggests that organizational development, leadership, and communication simultaneously have a significant contribution to the work motivation. Thus the work motivation of teachers in Islamic boarding school can be improved by developing the organization, effective leadership, and improve the quality of communication.

Evidence of organizational development, leadership, communication partially or simultaneously influence the work motivation suggests that the most dominant dimension is the dimension of organizational development with the highest dimension value on human dimensions, that is 0.748. Thus the human dimension must be maintained, especially indicators that have the highest value, namely determination indicator. While other dimensions of each variable must be improved either partially or simultaneously in order to work motivation of teachers in Islamic boarding school increased.

Organizational development, leadership, communication, and motivation affect teachers; it's proven by commitment to the value of R square of 0.903. This suggests that organizational development, leadership, communication, and work motivation simultaneously have a significant contribution to the commitment of teachers. Based on these findings, a commitment means teachers can be improved by developing organizational Islamic boarding school, leadership, organizational communication, and work motivation either partially or simultaneously, with the most dominant variable is work motivation which has highest score in internal dimension of 0,799. Thus the internal dimension must be maintained, especially indicator which has the highest value, that is the indicator of scholarship/diploma appreciation.

G. Recommendation

Results of this study recommend that the commitment of Islamic boarding school teachers can be improved by motivating teachers in internal dimensions, especially those related to the indicators in the form of an appreciation of scholarship/diploma.

In addition, the organizational development of Islamic boarding school in the development of Human Resources (HR) is also a recommendation of this study to intensively continue to be implemented in order to increase the motivation of Islamic boarding school teachers.

As we know that the main source of inspiration forming ideology in Islamic boarding school community is the norm or the doctrine of Islam. Therefore, the cognitive orientation of Islamic boarding school community is of course aligned with the ideals of life which are harmonious to the norm or the doctrine of Islam.

On the other hand, the dynamics of today's social norms or ideals demanding doctrine of Islam which is indicated by a variety of empirical evidence as desired so that its significance can be felt not only at the later end of the day, but also can be felt in real life today.

To that end, in addition to the dogmatic approach, the need for rational and empirical approach in narrating various ideal norms or the doctrine of Islam become an absolute precondition for religious life in today's contemporary era.

In the education world of Islamic boarding school, rational and empirical approach are still a very rare item. Such an approach is more prevalent in the world of general disciplines (non-religious).

In consideration of the urgent need for the use of rational and empirical approach, the Islamic boarding school community efforts to get closer to the tradition of rational and empirical approach are also something that should be done immediately. This effort will enhance the appreciation of Islamic boarding school community member, especially teachers in the Islamic boarding school on the scholarship with a more complex domain, meaning that not only dogmatic theology, but religion which is supported by a narrative

born of rational and empirical approaches that are the result from the study of general disciplines (non-religious), finally increasing recognition of the ability of science will be able to increase the motivation of teachers.

Institutionally, the effort to bring Islamic boarding school community to the tradition of rational and empirical approach can be done by diversifying the areas of education studies at the institution in Islamic boarding school. More explicitly, the existence of institutions that assess general disciplines (non-religious) as a complement domain studies in an Islamic boarding school can be a real choice effort that is very strategic.

In turn, output of educational institution that studies the general disciplines (non-religious) will strengthen the narrative of Islamic norms, and ultimately will strengthen belief about the importance of achieving an organizational goals determined together.

Strong beliefs about the importance of achieving an organizational goals determined together will further strengthen the position of the organizational direction as something that drive mind body motion the entire organization members. A strong belief about the importance of achieving determined organization goals strategically will increase the commitment of all teachers in Islamic boarding school.

Academic advice for the next researchers is to develop further research to expand the study of organizational development, leadership, communication, motivation, and commitment of teachers or other variables with different research objects.

Bibliography

- Arikunto, Suharsimi. 2010. *Prosedur Penelitian Suatu Pendekatan Praktek*. Jakarta: PT Rhineka Cipta.
- Caroselli, Marcelene. 2000. *Leadership Skill for Managers*. New York: McGraw-Hill.
- Daft, Richard L., 2008. *Management-manajemen*. Alih bahasa oleh: Diana Angelica. Jakarta: Salemba Empat.
- Hamalik, Oemar. 2007. *Proses Belajar Mengajar*. Jakarta : PT Bumi Aksara.
- Handoko, T. Hani. 2003. *Manajemen, jilid 2*. Yogyakarta : BPF.
- Kreitner dan Kinicki, Angelo. 2003. *Organizational Behavior*. New York : McGraw-Hill Compaines, Inc.
- Luthans, Fred., Sweeney, dan McFarlin. (2002). *Organizational behavior: Solutions for Management*. New York: McGraw-Hill Company.
- Laka-Mathebula, M.R. (2004). *Modelling the Relationship Between Organizational Commitment Leadership Style, Human Resource management Practices and Organizational Trust*. Faculty of Economic and Management Science: University of Pretoria. hlm. 15

- Mathis dan Jackson, Angelo. 2001. *Perilaku Organisasi*, Buku 1, Edisi Kelima, Jakarta: Salemba Empat.
- Siagian, Sondang. P. 2004, *Pengembangan Sumber Daya Insani*, Jakarta: Gunung Agung.
- Spillane, James P. 2006. *Distributed leadership*, San Francisco: Jossey Bass.
- Stuart, Robert D. and Barbara B. Morgan. 2002. *Library and information centre management*, USA: Library Unlimited.
- Waluyo, Minto. 2009. *Panduan dan Aplikasi Struktural Equation Modelling (untuk Aplikasi Model dalam Penelitian Teknik Industri, Psikologi, Sosial dan Manajemen)*, Jakarta : PT Indeks.