

# Comparison of LFC Optimization on Micro-hydro using PID, CES, and SMES based Firefly Algorithm

Kadaryono

Department of Mechanical Engineering  
University of Darul Ulum  
Jombang, Indonesia  
aninanin110@gmail.com

Rukslin

Department of Electrical Engineering  
University of Darul Ulum  
Jombang, Indonesia  
rukslin@gmail.com

Machrus Ali

Department of Electrical Engineering  
University of Darul Ulum  
Jombang, Indonesia  
machrus7@gmail.com

Askan

Department of Mechanical Engineering  
University of Darul Ulum  
Jombang, Indonesia  
askanzamzam@gmail.com

Asnun Parwanti

Department of Civil Engineering  
University of Darul Ulum  
Jombang, Indonesia  
asnunparwanti@gmail.com

Iwan Cahyono

Department of Civil Engineering  
University of Darul Ulum  
Jombang, Indonesia  
cahyonoiwan15@gmail.com

**Abstract**—Micro-hydro gets potential energy from water flow that has a certain height difference. Potential energy is strongly influenced by high water fall. Potential energy through pipes, incoming turbines converted into kinetic energy. The kinetic energy of the turbine coupled with the generator is converted into electrical energy. Some components used for micro-hydro power generation, among others; intake, settling basin, headrace, penstock, turbine, draft tube, generator, and control panel. Water flows through the pipe into the turbine house so it can rotate the turbine blades. Turbine rotation is used to rotate a generator at the micro hydro generator. The most common problem with micro-hydro generating systems is inconsistent generator rotation caused by changes in connected loads. Load changes can cause system frequency fluctuations and may cause damage to electrical equipment. Artificial Intelligence (AI) is used to obtain the right constants to obtain the best optimization. In this study compare the control method, namely; Proportional Integral Derivatives (PID), Capacitive Energy Storage (CES), and Superconducting Magnetic Energy Storage (SMES). This study also compared the method of artificial intelligence between Particle Swarm Optimization (PSO) method has been studied with the method of Firefly Algorithm (FA). Overall this study compares 11 methods, namely methods; uncontrolled, PID-PSO method, PID-FA method, CES-PSO method, CES-FA method, SMES-PSO method, SMES-FA method, PID-CES-PSO method, PID-CES-FA method, PID-SMES - PSO, and PID-SMES-FA method. The results of the simulation showed that from the 11 methods studied, it was found that the PID-CES-FA method has the smallest undershoot value, ie  $-7.774e-03$  pu, the smallest overshoot value, which is  $4.482e-05$  pu, and the fastest completion time is 7.11 s. These results indicate that the smallest frequency fluctuations are found in the PID-CES-FA controller. Thus it is stated that the PID-CES-FA method is the best method used in the previous method. This research will use other methods to get the best controller.

**Keywords**—CES, Firefly Algorithm, micro-hydro, PID, SMES.

## I. INTRODUCTION

In micro-hydro operation, stability issues are of major concern. In order for the frequency to be always stable, the rotational speed of the generator must be fixed. The rotational speed of the generator can be affected by the size or the amount of the load. The addition of a very large load will reduce the rotating density, otherwise a large load reduction will accelerate the generator spin. So that the

frequency will increase and if passing the standard will harm the consumer electrical equipment.

Therefore, to support this micro-hydro performance, setting or controlling the load frequency is required, to always be in the work area. Micro-hydro control is done automatically by governing the governor. Servo motor as governor set the opening height, so that the incoming water flow can be adjusted with the load. So the system can adjust the load power and can reduce the frequency change[1].

Load Frequency Control (LFC) is designed using a controller; Proportional Integral Derivatives (PID), Capacitive Energy Storage (CES) [2], and Superconducting Magnetic Energy Storage (SMES)[3]. All three controllers are tuned using artificial intelligence, namely the method of Particle Swarm Optimization (PSO) and Firefly Algorithm (FA). Because, Artificial Intelligent (AI) is often used to develop various disciplines such as vehicle steering controllers [4][5], as micro-hydro control [6], and others. In this study used the method Firefly Algorithm (FA) [7]. The FA method is used as tuning PID, CES, and SMES controller. With this comparison obtained the best control method. The best results will be applied at micro-hydro plants in Jombang, East Java, Indonesia. This research involves scientists from various disciplines, namely; mechanical engineering, electrical engineering, and civil engineering.

## II. SYSTEM MODELING

### A. Micro-hydro Power Plant

The micro-hydro power plant on harnessing potential energy from the height difference and the amount of water discharge. The potential energy from the water passes through the pipe and rotates the turbine shaft to generate mechanical energy. This mechanical energy drives the generator and generates electrical energy. Micro hydro power plants must have a water source that always flows throughout the year. The electric power generated by the power generator ( $P_{th}$ ) depends on the value of the water discharge ( $Q$ ) and the waterfall height ( $H$ ). The equation can be formulated as follows::

$$P_{th}[W] = Q[m^3 / s].H[m].k[N / kg] \quad (1)$$

The efficiency ( $\eta_{gen}$ ) of the turbine and generator is determined by each manufacturer with a power factor value

of 0.8 causing the actual electrical value to be lower than the generator power ( $P_{th}$ ).

$$P_{real} [W] = Q[m^3 / s].H[m].k[N / kg].\eta_{turbine}.\eta_{gen} \quad (2)$$

For pumps used as turbines, the efficiency values varied from 0.6 to 0.8, in this study used 0.8. For cross-flow turbines, values varying from 0.5 to 0.7, in this study are used 0.6. While the generator used in the micro-hydro power plant system here is using an induction generator, a servo motor operated as a governor, and some components are modeled on the simulation using the Matlab-Simulink program. The following figure shows the configuration of the designed micro-hydro power plant.

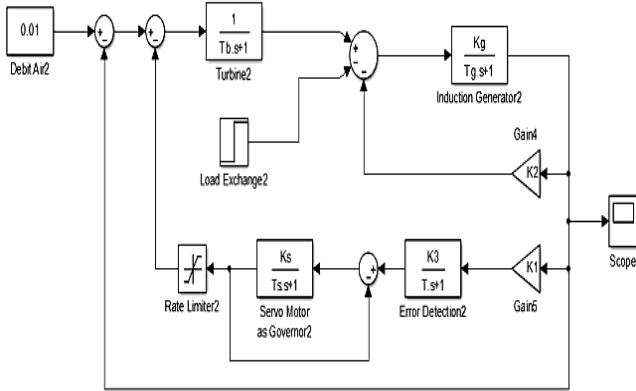

Fig. 1. Block diagram of Micro-hydro System[6]

The signal change ( $\Delta\omega$ ) will be forwarded to the servo motor block functioned as governor. The parameters required for signal strengthening are  $K_s$  and  $T_s$ . The output of the governor is passed to the limiter to limit the signal. Limiter is used to limit the highest and lowest saturation values in order not to exceed the specified value. The limiter output goes to the turbine block. The micro-hydro parameters used in this study can be shown in Table 1..

Table 1. Micro Hydro Parameter [6]

| Parameter | Value   | Item  |
|-----------|---------|---|
| Tb        | 1       | Water turbine time response (s)                   |
| Kg        | 1       | Reinforcement of inductor generator regulator (s) |
| Tg        | 13,333  | Response time on generator induction (s)          |
| K1        | 5       | Error Detection confirmation constant             |
| K2        | 8,52    | Frequency of frequency deviation constant         |
| K3        | 0.004   | Strengthening Error Detection                     |
| T         | 0,02    | Time response Error Detection                     |
| Ts        | 0,1     | The governor's time constant (s)                  |
| Ks        | 2,5     | Strengthening governor                            |
| Sg        | 40      | Micro-hydro power generator rating (kVA)          |
| pf        | 0,8     | Power Factor                                      |
| Vg        | 400/231 | Nominal voltage generator (V)                     |
| $\omega$  | 1500    | Nominal rotational speed (rpm)                    |
| fg        | 50      | The nominal frequency of micro hydro (Hz)         |

**B. Capacitive Energy Storage (CES)[2]**

Capacitive Energy Storage (CES) is a device used to store and release large amounts of electrical power quickly. CES consists of Storage Capacitors (SC) and Power Conversion Systems (PCS). The energy stored by the CES on the capacitor in the form of an electric field, can be shown in Figure 2.

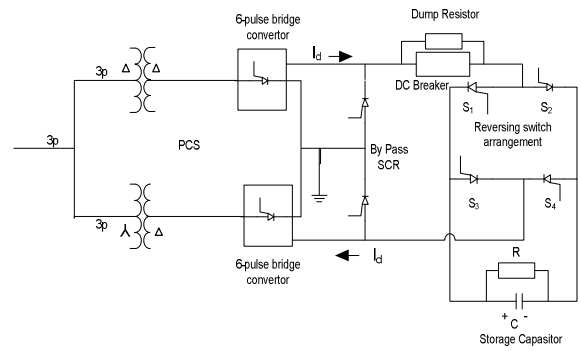

Fig. 2. Capacitive Energy Storage

Storage capacitors consist of discrete capacitors arranged in parallel. Storage capacitors are connected via a 12-pulse Power Conversion System (PCS) to Mesh. The leakage and dielectric energy losses of the bank capacitor at CES are modeled by resistors  $R$  in parallel with the capacitor ( $C$ ). PCS converts to DC and from DC to AC Inverter. Bypass Thyristor serves to provide the current path ( $I_d$ ) when the converter fails. The DC breaker diverts the current ( $I_d$ ) to the resistor point ( $R_d$ ) if the converter fails. The bridge voltage ( $E_d$ ) is shown in equations 3 and 4.

$$E_d = 2E_{d0} \cos \alpha - 2I_d R_D \quad (3)$$

$$E_{d0} = \frac{[E_{dmax}^2 + E_{dmin}^2]^{1/2}}{2} \quad (4)$$

If the system is interrupted, the capacitor voltage becomes too low and the voltage will return to its normal value quickly. The energy will be absorbed by the capacitor and can cause the control to be disconnected. To solve this problem, the lower limit for the capacitor voltage, taken 30% of the rating value ( $E_{d0}$ ). The lower limit of voltage can be seen in equation 5.

$$E_{dmin} = 30 E_{d0} \quad (5)$$

The CES voltage will return to its initial value quickly. After the disturbance occurs, the CES unit must be ready to work for subsequent load changes. The voltage deviation of the capacitor is used as a feedback signal in the CES control loop.

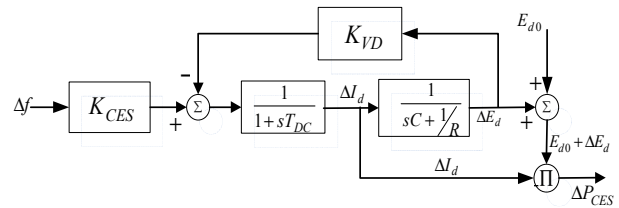

Fig. 3. CES Block diagram

Here's the voltage deviation of the capacitor  $\Delta E_d$ ,

$$\Delta E_d = \left[ \frac{1}{sC + 1/R} \right] \Delta I_d \quad (6)$$

CES output power released to the system during load changes is as follows,

$$\Delta P_{CES} = (E_{d0} + \Delta E_d). \Delta I_d \quad (7)$$

**C. Superconducting Magnetic Energy Storage (SMES)**

SMES stores energy in the magnetic field obtained from Direct Current (DC) into the cryogenic cooled superconducting coil. A SMES connected to a power system, consisting of a cryogenic cooling system, superconducting coil, and Power Conditioning System (PCS) with control and protection functions. PCS is commonly referred to as the power electronics center of the SMES coil. SMES schematic diagram can be seen in figure 4. [3].

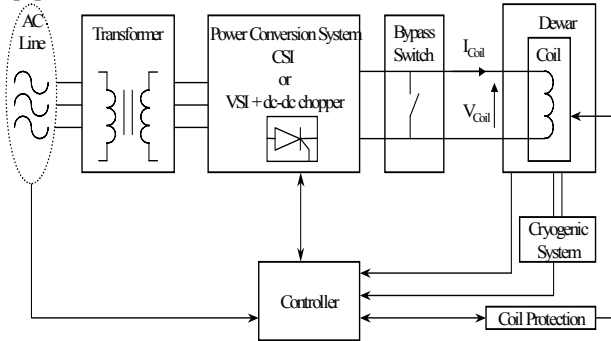

Fig. 4. SMES schematic diagram.

In principle, superconductors have near-zero losses at cold temperatures. The coolant used is Helium liquid which is able to cool to 4 K. PCS is used to transfer energy from the SMES coil to the system. A PCS uses a dc link capacitor to connect a voltage source from the SMES coil to the system. The working principle of SMES is divided into three, namely charging mode, standby mode and discharging mode. The SMES performance setting is performed by adjusting the duty cycle of the converter which in this case uses a Gate Turn Off (GTO) thyristor .

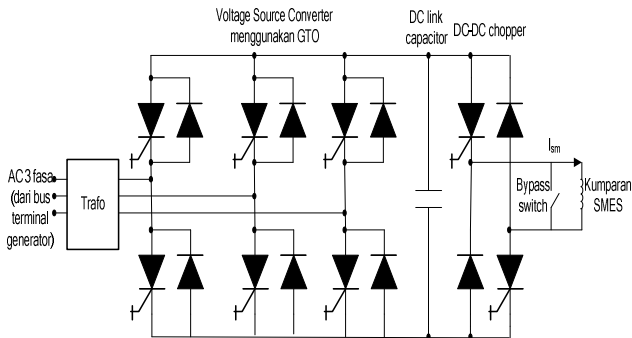

Fig 5. Configure SMES

To effectively control the power balance of the generator, SMES is placed on the bus terminal of the generator. From some SMES equations of reference, a block diagram of the SMES PID controller used is shown in Figure 6.

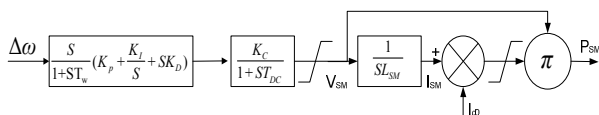

Fig 6. Block diagram PID SMES

In this study, PID-SMES is installed on micro-hydro power system. The PID-SMES installation is on the induced generator bus terminal when there is a burden of changing the load. The SMES parameters can be seen in Table 3.

Table 3. SMES Parameters

| Parameters | Tuning Value |
|------------|--------------|
| Ksmes      | 90           |
| Tdc        | 0.0176       |
| tw         | 7.6616       |
| Kp         | 8            |
| Ki         | 6.8462       |

**D. Firefly Algorithm (FA)[7]**

The method used to optimize the PID parameter is the Firefly Algorithm (FA) method. The algorithm was first discovered by Dr. Xin-She Yang at Cambridge University in 2007. The algorithm diagram of the Firefly Algorithm (FA) method used in this research study can be seen in Figure 3. The objective function used to test the stability of the system is with Integral Time Absolute Error (ITAE)[8][7].

$$ITAE = \int_0^t |\Delta\omega(t)| dt \tag{11}$$

The PID parameters set by FA are Kd, Kp, Ki. The data of the standard FA parameters used are shown in Table 4:

Table 4. FA Parameters

| Parameters          | Value  |
|---------------------|--------|
| Alpha               | 0.25   |
| Beta                | 0.2    |
| Gamma               | 1      |
| Dimensi             | 3      |
| Number of Fireflies | 50     |
| Maximum iteration   | 50     |
| Kp                  | 0 – 50 |
| Ki                  | 0 – 10 |
| Kd                  | 0 – 10 |

**E. Particle Swarm Optimization (PSO).**

This algorithm is inspired by the behavior of swarm in search of food. Particle Swarm Optimization (PSO) is defined as a swarm swarm that can define trajectories by their own best performance and groups. In this paper, swarm partition optimization solves the problem of performance optimization Load frequency control in reducing frequency fluctuations through the description of the algorithm to find the value of the constants PID, CES and SMES.[10][11].

The data of PSO parameters can be seen in Table 5.

TABLE 5. PSO PARAMETERS

| Parameters              | Value  |
|-------------------------|--------|
| Number of Particles     | 30     |
| Maximum iteration       | 50     |
| Number of Variables     | 3      |
| C2 (Social Constant)    | 2      |
| C1 (Cognitive Constant) | 2      |
| W (Momentum Inertia)    | 0.9    |
| Kp                      | 0 – 50 |
| Ki                      | 0 – 10 |
| Kd                      | 0 – 10 |

**III. RESULT OF SIMULATION AND ANALYSIS**

The design of some micro-hydro controllers can be seen in figure 7.

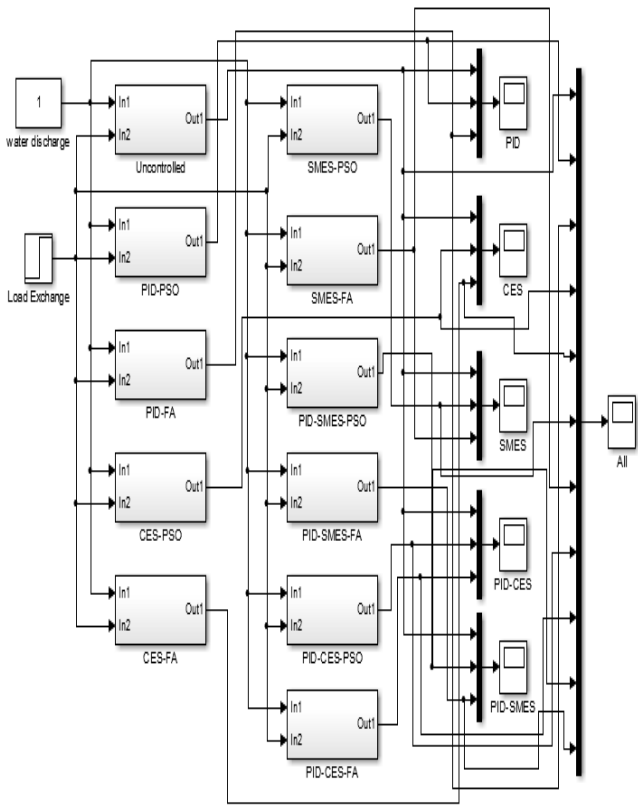

Fig.7. Micro-hydro controller design

Micro-hydro controller constants can be seen in Table 6, table 7, and Table 8;

TABLE 6. OPTIMIZATION RESULTS WITH PID

| Parameter | PSO       | FA        |
|-----------|-----------|-----------|
| Kp        | 16.790915 | 79.627021 |
| Ki        | 1.716562  | 7.161799  |
| Kd        | 0.091662  | 6.024251  |

TABLE 7. PID OPTIMIZATION RESULTS WITH CES

| Parameter | PSO     | FA      |
|-----------|---------|---------|
| Kces      | 69.4785 | 82.1232 |
| Tdc       | 0.01430 | 0.0643  |
| Kp        | 11.7909 | 49.6827 |
| Ki        | 1.7165  | 39.6212 |
| Kd        | 0.09166 | 6.1234  |

TABLE 8. PID OPTIMIZATION RESULTS WITH SMES

| Parameter | PSO     | FA     |
|-----------|---------|--------|
| Ksmes     | 81.302  | 90.634 |
| Tdc       | 0.02136 | 0.0176 |
| Twi       | 7.0321  | 7.6162 |
| Kp        | 7.0864  | 8.8642 |
| Ki        | 2.6744  | 6.8463 |
| Kd        | 0.0083  | 0.1932 |

By using the FA method obtained tuning PID controller with a large constant parameter  $K_p = 79.627021$ ,  $K_i = 7.161799$ , and  $K_d = 6.024251$ . With CES method, there are big constants  $K_{ces} = 82.1232$ ,  $T_{dc} = 0.0643$ ,  $K_p = 49.6827$ ,  $K_i = 39.6212$ , and  $K_d = 6.1234$ . With the method of SMES obtained constant  $K_{smes} = 90.634$ ,  $T_{dc} = 0.0176$ ,  $T_{wi} = 7.6162$ ,  $K_p = 8.8642$ ,  $K_i = 6.8463$ , and  $K_d = 0.1932$ .

Figure 8-13 shows the micro-hydro frequency response for each control design.

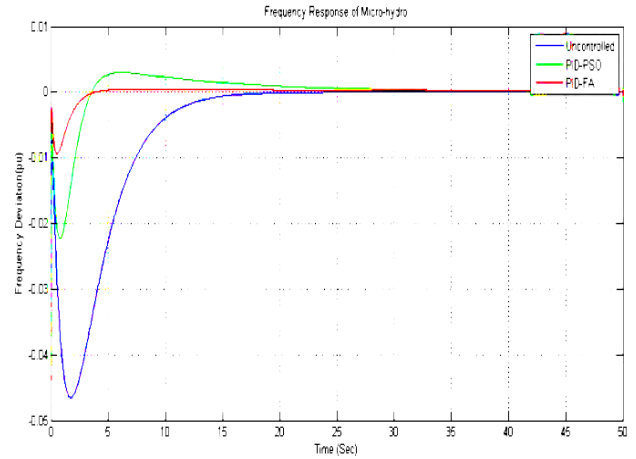

Fig. 8. Micro Hydro Frequency with PID

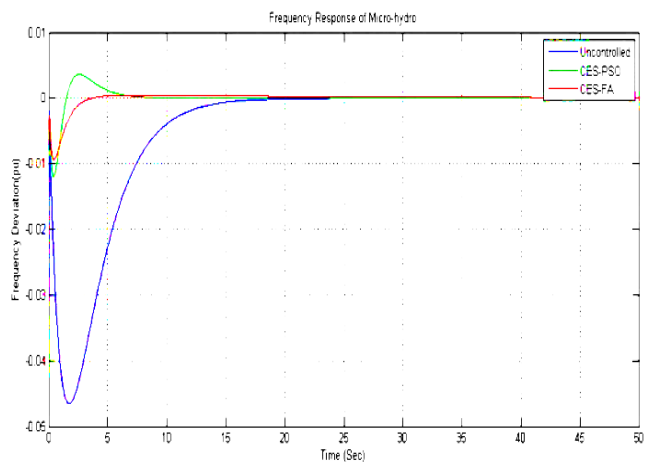

Fig. 9. Micro Hydro Frequency with CES

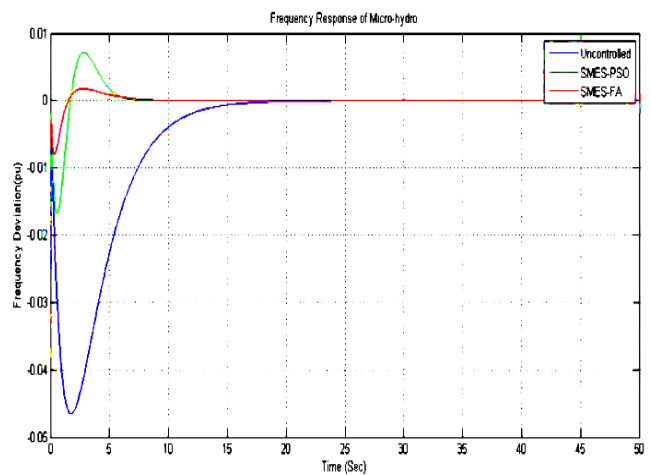

Fig. 10. Micro Hydro Frequency with SMES

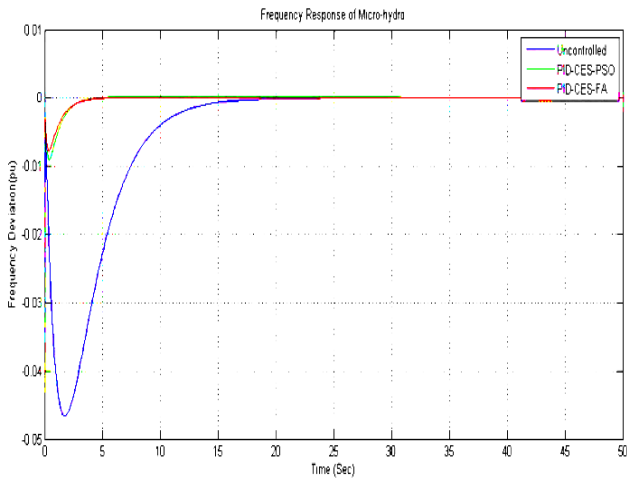

Fig. 11. Micro Hydro Frequency with PID-CES

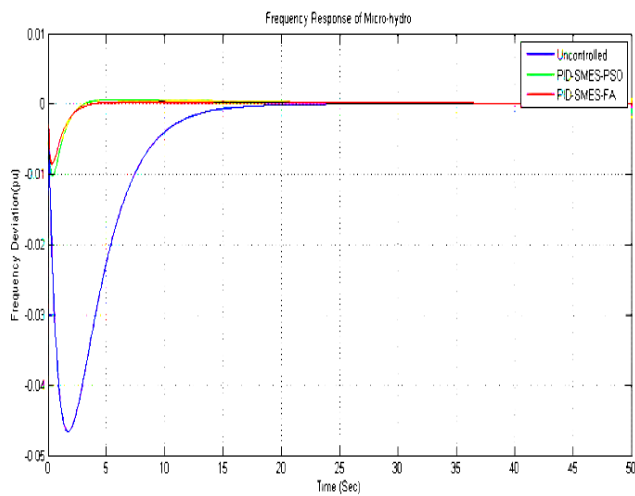

Fig. 12. Micro Hydro Frequency with PID-SMES

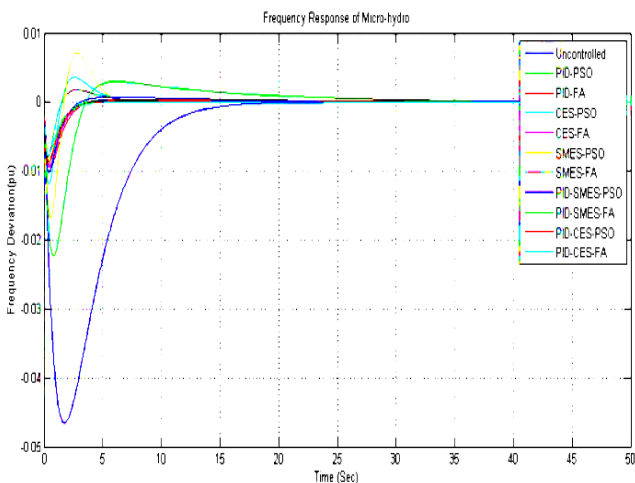

Fig. 13. Plot All Graphic of Control Model

The results of overshoot, undershoot and settling time can be seen in Table 9.

TABLE 9. OVERSHOOT RESULT OF EACH MODEL

| Controller   | Overshoot (pu) | Undershoot (pu) | Settling time (s) |
|--------------|----------------|-----------------|-------------------|
| Uncontrolled | 0.0000         | -4.661e-02      | 25.012            |
| PID-PSO      | 3.945e-04      | -2.242e-02      | 35.653            |
| PID-FA       | 2.985e-03      | -9.448e-03      | 15.653            |
| CES-PSO      | 3.582e-03      | -1.191e-02      | 9.883             |
| CES-FA       | 4.111e-04      | -9.375e-03      | 7.352             |
| SMES-PSO     | 7.154e-03      | -1.701e-02      | 21.342            |
| SMES-FA      | 1.961e-03      | -8.954e-03      | 19.763            |
| PID-CES-PSO  | 1.798e-04      | -9.063e-03      | 7.748             |
| PID-CES-FA   | 4.482e-05      | -7.774e-03      | 7.11              |
| PID-SMES-PSO | 7.000e-03      | -1.011e-02      | 17.863            |
| PID-SMES-FA  | 1.931e-03      | -8.531e-03      | 11.361            |

From Figure 8-13 and Table 9 shows that the overshoot, undershoot, and settling time of the method; uncontrolled (0.00, -4.661e-02, 25.012), PID-PSO method (3.945e-04, -2.242e-02, 35.653), PID-FA method (2.985e-03, -9.448e-03, 15.653), CES-PSO method (3.582e-03, -1.191e-02, 9.883), CES-FA method (4.111e-04, -9.375e-03, 7.352), SMES-PSO method (7.154e-03, -1.701e-02, 21.342), SMES-FA method (1.961e-03, -8.954e-03, 19.763), PID-CES-PSO method (1.798e-04, -9.063e-03, 7.748), PID-CES-FA method (4.482e-05, -7.774e-03, 7.11), PID-SMES – PSO (7.000e-03, -1.011e-02, 17.863), and PID-SMES-FA method (1.931e-03, -8.531e-03, 11.361). The simulation results show that the PID-CES-FA method has the smallest undershoot value, ie -7.774e-03 pu, the smallest overshoot, ie 4.482e-05 pu, and the fastest settling time of 7.11 s. thus it is stated that the PID-CES-FA method is the best method used from the previous method..

#### IV. CONCLUSION

By using Firefly Algorithm (FA) as the method of tuning the Capacitive Energy Storage (CES) controller, the result of tuning of CES parameter for  $K_{ces}$  88,8888,  $T_{dc}$  is 0.0563,  $K_p$  is 63.6297 and  $K_i$  is 43.7886, and  $K_d$  is 9.6385. The simulation results show that the PID-CES-FA method has the smallest undershoot value, ie -7.774e-03 pu, the smallest overshoot, ie 4.482e-05 pu, and the fastest settling time of 7.11 s. thus it is stated that the PID-CES-FA method is the best method used from the previous method.

#### V. REFERENCES

- [1] D. Henderson, "An advanced electronic load governor for control of micro hydroelectric generation," *IEEE Trans. Energy Convers.*, vol. 13, no. 3, pp. 300–304, 1998.
- [2] I. T. Yuniastuti, I. Anshori, and I. Robandi, "Load frequency control (LFC) of micro-hydro power plant with capacitive energy storage (CES) using bat algorithm (BA)," in *Proceedings - 2016 International Seminar on Application of Technology for Information and Communication, ISEMANTIC 2016*, 2017, pp. 147–151.
- [3] M. R. I. Sheikh, S. M. Mueen, R. Takahashi, T. Murata, and J. Tamura, "Minimization of fluctuations of output power and terminal voltage of wind generator by using STATCOM/SMES," in *2009 IEEE Bucharest PowerTech: Innovative Ideas Toward the Electrical Grid of the Future*, 2009.

- [4] M. Ali, F. Hunaini, I. Robandi, and N. Sutantra, "Optimization of active steering control on vehicle with steer by wire system using Imperialist Competitive Algorithm (ICA)," in *2015 3rd IEEE -International Conference on Information and Communication Technology, ICoICT 2015*, 2015, pp. 500–503.
- [5] H. Kusuma, M. Ali, and N. Sutantra, "The comparison of optimization for active steering control on vehicle using PID controller based on artificial intelligence techniques," in *Proceedings - 2016 IEEE- International Seminar on Application of Technology for Information and Communication, ISEMANTIC 2016*, 2017.
- [6] M. Muhlasin, R. Rukslin, A. Raikhani, and M. Ali, "The FA-ANFIS Hybrid Method is used for LFC Optimization in Micro Hydro Power Generation," in *Seminar Nasional Teknik Elektro (FORTEI 2017)*, 2017, pp. 225–229.
- [7] X. S. Yang, "Firefly algorithms for multimodal optimization," in *Lecture Notes in Computer Science (including subseries Lecture Notes in Artificial Intelligence and Lecture Notes in Bioinformatics)*, 2009, vol. 5792 LNCS, pp. 169–178.
- [8] M. Alb, P. Alotto, C. Magele, W. Renhart, K. Preis, and B. Trapp, "Firefly Algorithm for Finding Optimal Shapes of Electromagnetic Devices," *IEEE Trans. Magn.*, vol. 52, no. 3, pp. 1–4, 2016.
- [9] X. S. Yang, "Firefly Algorithm," *Nature-Inspired Metaheuristic Algorithms*, pp. 79–90, 2007.
- [10] T. M. Blackwell, J. Branke, and X. Li, "Particle Swarms for Dynamic Optimization Problems," *Swarm Intell.*, vol. 52, no. 1, pp. 193–217, 2008.
- [11] Z.-H. Zhan, J. Zhang, Y. Li, and H. S.-H. Chung, "Adaptive particle swarm optimization.," *IEEE Trans. Syst. Man. Cybern. B. Cybern.*, vol. 39, no. 6, pp. 1362–1381, 2009.